

UPHOLSTERED FURNITURE TEST METHOD

1.0 Scope

This test method describes procedures for evaluating the most important performance characteristics of seats, backs, arms, and legs of upholstered sofas, dual purpose (seating/sleeping) units, recliners, and lounge chairs. The method is independent of materials, methods, and types of construction, and may be carried out on either fully or partially upholstered versions of the aforementioned furniture products. Results of the tests provide a means for the subsequent ranking of the products according to their performance. The term "specimen" will hereinafter be used to refer to the sofa, dual purpose unit, recliner, or lounge chair that is undergoing testing.

Instructions are given for constructing the equipment needed to carry out the tests, and detailed drawings of the equipment and photographs of individual tests are provided.

The material covered in these methods appears in the following order:

CONTENT	SECTION
Scope	1.0
Summary of the Method	2.0
Definitions	3.0
Test Specimens	4.0
Conditioning of the Specimens	5.0
Common Test Equipment	6.0
Description of Tests	7.0
Reporting	8.0

2.0 Summary of the Method

The upholstered specimen is subjected to a set of forces which is applied to the seat, back, arms, or legs at selected positions at a repeating rate of twenty cycles per minute. The test is continued at this force level until 25,000 cycles have been completed. Subsequently, forces are increased by a given increment and the test continued for another 25,000 cycles. This process is repeated until a part of the seat or backrest foundation system, an arm, a leg, or a part of joint in the frame suffers disabling damage or until a desired level of performance is achieved. The performance rating of the specimen is taken as the highest force level at which all parts tested were able to successfully complete 25,000 force cycles.

3.0 Definitions

3.1 Disabling damage - damage to a joint or part which is sufficiently great to prevent the seat foundation system, the backrest foundation system, the frame system, or any of the above subsystems from performing their intended functions. Breakage of a spring is treated as a failure as is breakage of any foundation support element. Minor loosening of a joint or joints in a frame is not treated as a failure; a part of a joint must completely cease to sustain force before the test is stopped for frame failure.

3.2 Air line oiler or lubricator - a device which is used to add small amounts of oil to the air. This oil is needed for lubrication of the cylinders and the air valves.

3.3 Speed control valve - an air valve which allows air to flow through it freely in one direction but at a controllable reduced rate in the other direction.

3.4 Force dynamometer - in essence, a very accurate spring-type scale which can be used to measure forces and loads.

3.5 Testing machine frame - a frame made up of pipes and scaffolding clamps. Usually this framework is anchored to the floor. Furniture frames placed within this framework are subjected to forces applied by air cylinders which are attached to the members of the testing machine frame.

3.6 Air cylinder - a device for converting fluid power energy into linear mechanical force and power; i.e., a device which converts confined air acting on a piston into a force acting along a desired line of action.

3.7 Scaffolding clamp - a clamp which is used to attach two pieces of pipe together. These clamps are normally used to fabricate scaffolding for building purposes from pipe - hence, the name scaffolding clamps.

3.8 Floor flange - a flat flange which may be screwed onto the end of a piece of threaded pipe. Ordinarily, a floor flange has holes drilled through it so that it may be anchored to the floor with screws. Such flanges are often used to attach handrails or guard rails to concrete walks and steps.

3.9 Moisture content of wood - the amount of moisture the wood contains expressed as a percentage of its bone dry weight.

3.10 Upholstered furniture frame - the bare wood, metal, etc. frame used in construction of an upholstered sofa or chair.

3.11 Upholstered sofa [dual purpose unit][recliner][chair] - a sofa [dual purpose unit][recliner][chair] which is in the final state as offered for sale to the consumer.

4.0 Test Specimens

4.1 The test specimen shall consist of an upholstered sofa, dual purpose (seating/sleeping) unit, recliner, or lounge chair. It shall be manufactured under normal production line conditions and shall use the same materials and construction techniques found in production products. Any deviation from normal procedures or the inclusion of materials not regularly used or in amounts not regularly used is to be clearly noted in the final report. The same test specimen is not required to be used for all applicable tests. If desired for expediency, use of multiple test machines as described herein is acceptable for performing different tests concurrently on more than one identical test specimen.

4.2 If more than one species of wood is used in the frame, the species of wood having the lowest USDA Wood Handbook (2, 5) modulus of rupture shall be used in the specimens to be tested.

4.3 Within a matching series (e.g., 3-place sofa, loveseat and lounge chair), only the largest item (the 3-place sofa in this example) of the series need be tested provided that the same seat support system and construction methods are utilized in all items. Any item of the series that utilizes a seat support system and/or construction method different from the largest item, must also be tested.

5.0 Conditioning of the Specimens

Specimens should be maintained at humidity levels which fall within those normally found in service. Relative humidities within the range of 40 to 65 percent will satisfy these conditions.

6.0 Test Equipment

6.1 Common Test Equipment

Test equipment is described as follows:

- a. A testing machine frame in which the furniture frames can be mounted for testing and which also provides points of attachment for the load frames and the various jigs and fixtures required for testing the specimen frames.
- b. Air cylinders for applying forces to the furniture.
- c. Pressure regulators to control and adjust the magnitude of the forces applied to the furniture and an air control system to control the cyclic rate of applying forces and the relative length of the on/off cycles.
- d. A predetermined counter to record the number of cycles and to terminate the test when a desired number have been completed.
- e. A force dynamometer to calibrate the air cylinders and to periodically monitor the forces applied to the furniture.

6.1.1 Testing Machine Frame

The external testing machine frame may consist of a rectangular skeletal steel framework fabricated from pipe and scaffolding clamps. This framework provides points of attachment for the various devices which are used to apply forces to the furniture, and it also provides a means of supporting and holding the furniture in place while it is being tested.

Overall size of the testing machine is not critical, but it must provide sufficient space for the specimen and apparatus used to apply forces, to be mounted properly as well as sufficient space for servicing of the equipment. A typical testing machine framework is shown in Figure 1. Corner posts about 8 feet high are anchored to the floor; crossbars are attached to these posts to form the frame of the machine. All of the frame members are constructed of nominal 2-inch diameter heavy wall (schedule 80) steel pipe. Scaffolding clamps, Figure 2, are used to join the members together to form a rigid frame. The frame is attached to the floor by means of special floor flanges, Figure 3a. These flanges are particularly useful for attaching the frame corners to single anchor bolts set in concrete floors. Standard flanges of the type shown in Figure 3b may also be used.

The scaffolding clamps provide considerable rigidity to the frame, and it should not be necessary to brace the testing machine frame in any way. Should this prove necessary, however, additional pipes and clamps may be used to insert diagonals in the side frames.

The testing machine frame should be given regular maintenance while testing; specifically, the set screws in the scaffolding clamps should be regularly tightened. Scaffolding clamps may also break if they are subjected to high force levels for a great number of test cycles. If this problem should occur, additional members should be added to the testing machine frame at critically stressed points to share the load. Safety chains hooked over the tops of the corner posts or over the top of intermediate posts should be used to ensure that a crossbar cannot fall if a clamp should loosen or fail.

The equipment described in this method is closely related in concept to that described in document FEHS-78-125, The Performance Test Method for Upholstered Furniture. That document (3), accordingly, provides additional information concerning construction details and known sources of supply when it was written.

6.1.2 Air Cylinders

At least six air cylinders are required to carry out the tests described in this document, but it is convenient to have an extra cylinder on hand which can be used solely for force calibration purposes. Cylinders with a bore of 2-1/2 inches and a stroke of 18 inches are well-suited for use in the tests and are compatible with the load frames developed, but their use is not mandatory. The cylinders shall, however, have sufficient length of stroke to allow the

seats and the backrests to deflect fully. If cylinders with too large a bore diameter are used, they may be difficult to calibrate and control at the lower force levels because of the practical limits of accuracy of the air regulators at low air pressure levels.

The quality of the cylinders used is optional, but medium duty cylinders should give satisfactory service under laboratory conditions. Additional information concerning the performance characteristics and expected service life of air cylinders may be obtained from the National Fluid Power Association¹ as well as from individual manufacturers.

The following standards published by the American National Standards Institute² may also be of help in selecting cylinders:

1. B93.1-1964 (R1994) Fluid Power Cylinders, Dimension Identification Code for.
2. B93.2-1986 Glossary - Fluid Power Systems and Products.
3. B93.3-1984 (R1997) Cylinder Bores and Piston Rod Diameters – Inch Series.

To simplify attachment of the cylinders to the load frame devices, the cylinders should be equipped with a clevis mounting plate; in addition, the ends of the piston rods should be threaded internally to receive a male rod end bearing.

6.1.3 Pressure Regulator and Cyclic Control System

6.1.3.1 Examples of the electrical cyclic control apparatus and pressure regulation system are shown in Figure 4. A two-cam repeat-cycle timer is used to control the length of the on/off portion of each cycle and the rate at which the test is carried out. Rotational speed is 20 cycles per minute. The cams should be adjusted individually to provide on/off cycles similar to those described in Figure 5. Use of a two-cam timer allow for individual control of the front and rear of the load heads which is required in the seat load tests.

6.1.3.2 Standard 3/8-inch, three-way solenoid valves are used to control the flow of air to the cylinders. These valves control the flow of air to both sides of a cylinder. Pipe trees are connected to the outlet ports of each valve so that three cylinders can be operated from each of the four valves. Twenty-foot lengths of 3/8-inch (ID) diameter hose are used to connect the valves to the cylinders. Use of equipment of this size is mandatory to ensure that desired force levels can be developed and maintained.

6.1.3.3 Operating pressure is controlled by standard air regulators: oilers are included in the circuit to provide the lubrication needed by the valves and air cylinder.

6.1.4 Cycle Measurement and Termination of Test

Electrically operated predetermined counters are used to count the number of cycles and to stop the tests after a preset number of cycles have been completed. These counters have internal electrical switches which open when a preset number of cycles have been completed. The counters are wired into the electrical control circuit as shown in Figure 4.

6.1.5 Force Dynamometer

The force dynamometer used to calibrate and periodically monitor the force exerted by the air cylinders on the furniture frame is shown in Figure 6. It has a 1000 pound force capacity and an 8-inch diameter face which has been divided into 5-pound force increments for easy reading. A frame constructed from pipe and scaffolding clamps in

¹ National Fluid Power Association; 3333 N. Mayfair Road; Milwaukee, WI 53222-3219.

² American National Standards Institute; 11 West 42nd Street; New York, NY 10036.

which the dynamometer and an air cylinder can be placed for calibration is also shown in Figure 6. Desired force levels are obtained by adjusting the air regulator while the air valve is operating at its normal cyclic rate. Design of the testing equipment is such that a cylinder can readily be detached from the testing machine and inserted in the calibration frame. When matched cylinders are used, however, a spare cylinder mounted in the calibration frame can be used to calibrate identical cylinders without removing them from the testing machine (an extra cylinder is required if this procedure is followed, however).

When calibrating cylinders at high pressure levels, the cylinders may cause near impact loading of the force dynamometer which may damage the interior force indicating mechanism. To reduce rate of force application, speed control valves should be used which can be seen attached to the inlet port of the calibration cylinders in Figure 6.

6.2 Specific Test Equipment

6.2.1 Apparatus for Seat Load Test

6.2.1.1 Seat Load Frames (Figures 7a through 8)

An exploded view of the construction of a typical load frame used in the cyclic seat force tests is shown in Figure 7a. Two load frames are used at each seat position since the use of two frames permits the independent movement and application of force at the front and rear portions of the load head. One load frame is attached 2 inches from the front edge of the head and the second 11-3/8 inches further to the rear, Figure 8. The load heads are pivoted so that they are free to move in a front to back direction and thereby avoid any "binding" as the load head sinks into the seat and simultaneously deflects to the rear. The load heads are attached to the load frames by means of rod end-bearings, Figure 8, so that the heads themselves are able to rotate or tilt sideways as well as in a front to back direction. The amount of tilting permitted is limited by the spacing between the angle iron brackets which form the clevises to which the rod ends are attached.

Each of the load frames consists of two basic units-- an internal and an external load frame, Figure 7a. The internal frame consists of two vertical extension shafts which are joined together at one end by two elbows and a crossbar to form a U-shaped frame. The external frame consists of two vertical extension shaft sleeve bearings which are joined together at one end by two Tees and a crossbar to form a second U-shaped frame. Diameter of the pipe used in the internal frame is one inch; diameter of the pipe used in the external frame is 1-1/4 inches. The internal extension frame, therefore, is free to slide up and down inside the external frame.

The external frame differs from the internal in that the cross bar passes through a sleeve (crossbar sleeve) which acts as a bearing. The clevis end of an air cylinder is attached to the crossbar at its midlength. The rod end of the cylinder is attached to the crossbar of the internal frame at its corresponding midpoint. As the cylinder extends and retracts in operation, the internal load frame necessarily follows. The action of the air cylinder is thereby transmitted to the load frame which in turn transmits it in a controlled and directed manner to the seat of the specimen. Importance of the load frame to the cylinder lies in the fact that the frame prevents side thrust forces from being transmitted to the item. Thus, only axial forces are applied to the piston rod and the neck bushing of the cylinder.

Length of retraction of the internal frame in a vertical direction upward is controlled both by the air pressure supplied to the cylinders and also by positive stops or collars which can be seen in Figure 8. These may be positioned on the internal extension shaft frame members to limit the height to which the frame may be raised. Collars similar to these may also be used at the extreme upper end of these members in order to limit the downward movement of the frame--in case a seat foundation should collapse. Otherwise, this movement is limited only by the resistance provided by the seat or by the length of stroke of the cylinder. If desired, limit switches may be used to terminate the test after a specified deflection of the seat has been exceeded. These switches are connected into the electrical circuitry at the point labeled safety or stop switch in Figure 4.

A bill of materials for each of the seat load frames is given below.

Bill of Materials

Internal Load Frame

- 2 each, extension shafts, 1 inch x 48 inch
- 2 each, Ells, 1 inch
- 1 each, crossbar, 1 inch x 5-1/2 inch
- 2 each, setscrew collars, 1-1/4 inch inside diameter

External Load Frame

- 2 each, extension shaft sleeve bearings, 1-1/4 inch x 16 inch
- 2 each, Tees, 1-1-4 x 1-1/4 x 2 inch
- 1 each, crossbar, 1-1/2 inch x 5 inch
- 1 each, crossbar sleeve, 2 inch x 3-1/2 inch, heavywall

In constructing these frames, it is necessary to insure that the spacing between the longitudinal axes of the vertical extension shafts in the internal frames is identical to that between the longitudinal axes of the extension shaft sleeve bearings in the external frame.

The external frames are supported by a length of 2-inch diameter pipe which passes in a horizontal direction above the crossbar sleeves of the external load frames, Figure 7b. The clevis end of the air cylinder is attached to the external load frame by means of a male rod end which threads through a hole in the external load frame crossbar into a nut contained within the crossbar itself, Figure 7c. The 2-inch diameter heavywall sleeve is slotted halfway around its circumference with a one-inch wide slot to allow the external sleeve to rotate a few degrees around the crossbar. This allows the load frames to swing in a front to back direction. The sleeve may be slotted by first drilling a one-inch diameter hole through the 2-inch diameter sleeve at midlength and then cutting out the wall on the one side with a hacksaw to form a slot. A one-inch diameter hole drilled through the outside wall of one of the Tees in the external load frame allows a nut to be inserted into the crossbar and held while the male rod end is threaded into it. A long pair of tweezers can be used to insert and hold the nut.

Two rod ends and one clevis are needed to complete the frame. They have not been included in the bill of materials since they must be sized to agree with the air cylinder used. The extension shaft stops have not been described in detail; however, they can be constructed from short lengths of 1-1/4-inch diameter pipe. A hole is first drilled through one side of the pipe. A nut is then positioned over this hole in such a position that the longitudinal axis of the nut coincides with the corresponding axis of the hole and is then welded in place. A bolt or set screw threaded into the nut is then used to lock the collar in place on the extension shafts. Alternatively, setscrew collars for conventional drive shafts may be adapted to this purpose.

6.2.1.2 Construction of the Seat Load Head

The configuration of the seat load head used in the test is shown in Figure 9. This load head is identical to that specified by the Society of Automotive Engineers for tests of automotive seating (4). These heads may be constructed by laminating together 1-inch thick pieces of lumber which have first been cut roughly to shape. The resultant assembly may then be sanded with a belt sander to produce the desired form.

Brackets, which may be cut from angle iron, are attached to the back face of the load head to provide points of attachment to the seat load frame. The connection between the load head and the load frame is effected by means of rod ends, Figure 8. Position of the brackets with respect to one another determines the freedom of movement of the head; hence, it may be necessary to experiment to obtain the proper location and spacing for the specific rod end used.

The weight of the head at each of the two force points is determined, and the heads then weighted with steel or lead to bring the total weight of load head plus load frame to a standard value such as 50 pounds at both the forward and the rear force points.

6.2.2 Apparatus for Back Load Tests

6.2.2.1 Backrest Load Frames (Figures 10 through 16)

An exploded view of the construction of the load frames used in the backrest tests is given in Figure 10. A bill of materials for each of these frames is given below.

Bill of Materials

Internal Load Frame

- 2 each, Ells, 1 inch
- 2 each, extension shafts, 1 inch x 48 inch
- 1 each, crossbar, 1 inch x 6 inch

External Load Frame

- 2 each, reducing Tees, 1 inch x 1-1/4 inch
- 1 each, crossbar, 1 inch x 5-1/2 inch
- 2 each, extension shaft sleeve bearings,
1-1/4 inch x 16 inch
- 4 each, Tees, 1-1/4 inch
- 2 each, close nipples, 1-1/4 inch
(to form crossed Tees)
- 4 each, close nipples, 1-1/4 inch
(for bearings in crossed Tees)
- 1 each, cross pin, 1 inch x 12 inch
- 2 each, end caps, 1 inch
(for cross pin)

Swivel Support Column

- 1 each, Tee, 1-1/4 inch
- 1 each, close nipple, 1-1/4 inch
- 1 each, reducing coupling, 1-1/2 to 2 inch
- 1 each, swivel column, 1-1/2 inch x 20 inch
- 1 each, swivel column sleeve bearing,
2 inch x 18 inch (heavy wall pipe)

The load frames for testing the backrests are similar to those for testing seats, but important differences do exist, Figure 10. Again, each load frame consists of two basic units--an internal and an external frame. The internal frame consists of two extension shafts constructed of 1-1/4-inch diameter pipe which are joined together at one end by a crossbar to form a U-shaped frame. The external frame consists of two extension shaft sleeve bearings joined together at one end to form a second U-shaped frame. These pipes are 1-1/4 inches in diameter, however, so that the internal frame is free to slide within it. Crossed Tees, attached to the two free ends of the extension shaft sleeve bearings of the external frame, act as bearings for a shaft inserted through them. These two bearings together with a one inch diameter pipe inserted through them form part of a hinge which allows the backrest load frame to pivot up and down and thereby follow the natural movement of the backrest as the load head pushes against it. The other half of the hinge is formed by a Tee attached to the end of the 1-1/2-inch diameter pipe which acts as a vertical load frame swivel column. This pipe, or swivel support column, in turn, fits inside of a two-inch diameter sleeve (swivel sleeve bearing), Figure 11. This two inch sleeve is firmly attached to the testing machine frame in a vertical position by means of scaffolding clamps; the 1-1/2-inch diameter pipe is free to rotate within it so that the load frame and the load head attached to it are free to swing from side to side, Figure 12. The 1-1/2-inch diameter pipe is prevented from sliding out of the two-inch diameter sleeve by means of a pin which passes through the inner pipe near its upper end,

Figure 13. This pin rides on the upper end of the sleeve and carries the full weight of the load frame apparatus. A shallow V-groove is cut into the top of the sleeve so that the weight of the backrest load frame acting on the pin causes the pin to index into the bottom of the groove in the same location each time the cylinder retracts. This arrangement allows the load frame and load head to follow any side to side movement of the backrest during a force cycle and then return and index in the proper starting position automatically.

The head of the air cylinder is supported by means of a small chain which is looped over the hinge pin and the body of the cylinder as shown in Figure 11. Ends of the chain are joined together by means of a spring which allows some movement of the cylinder and thereby avoids binding. The cylinder should be positioned in the frame so that the rod end of the piston rod fits into the eye of the clevis without applying sidethrust force to the piston rod. If a clevis with a slightly oversized opening is used to attach the rod end-bearing to the load frame, and if it is turned so that the pin is in a vertical position, it will allow the rod end-bearing to slide up and down on the pin slightly and thus relieve any accompanying side thrust forces on the piston rod as the load frame extends and retracts as it deflects under force.

The rear end of the air cylinder, which is equipped with a clevis, is attached to the external load frame by means of a male rod end-bearing. The body of the bearing passes through the crossbar of the external load frame and is secured with a nut on the opposite side, Figure 14.

A small metal strap constructed of 1/8-inch thick steel with eyes drilled at each end is attached to the load frame by means of the nut just described, Figure 14. This strap provides a point of attachment for a spring/turnbuckle/chain linkage which controls the angle of the load frame with respect to the horizontal.

The complete linkage is shown in Figure 15. The rear of the external load frame should be weighted so that the total load frame is just balanced when the internal load frame is fully extended. If the backrest deflects downward as force is applied, the load frame retracts, however, the weight at the rear of the external load frame causes the entire load frame to return to its original starting position.

The load head is attached to the end of the load frame by means of a bracket and rod end, Figure 16. Clearances between the bracket, the rod end, and the end of the load frame are such that the load head itself is free to pivot both up and down and rotate from side to side predetermined amounts about the rod end. This freedom of movement allows the load head to adjust to local changes in the shape and angle of the backrest.

6.2.2.2 Backrest Foundation Load Heads

Configuration of the backrest foundation load heads is shown in Figure 17. This load head is identical to that specified in British Standard 4875 for the testing of sofa backs (1). The load heads may be fabricated from solid wood. Angle iron brackets attached to the back of the load head may be used to form a clevis. A male rod end whose shaft is bolted to the load frame connects the load head to the load frame, Figure 16. Articulation of the load head is governed by the opening width of the clevis and by the location of the hole. Some experimentation may be necessary to determine the optimum location for the specific rod end used. In general, however, the load head should have sufficient freedom of movement to follow the deflection of the backrest without binding.

6.3 Discussion

Experience with the equipment described has been favorable. It is relatively inexpensive, simple, fool-proof, and easily maintained. It can be easily constructed from readily available materials without precision machining. Furthermore, the simple joint systems used allow the load heads to follow the complex motions of the various parts of the furniture and re-index into the proper position at the end of each force cycle-- a degree of freedom of movement which is difficult to obtain with such simple low cost equipment.

7.0 Description of Tests

7.1 Seat Load Test

7.1.1 Summary of the Test Method

The cyclic vertical seat load test consists of subjecting the seat of the specimen to the "sitting action" of one or more identical load heads, depending on the type of specimen (i.e., number of seating positions). These forces are applied at the midpoint of each seating position, determined as follows:

No. of Seating Positions	Force Application Points
4	4: at points 1/8 and 3/8 the length of the open face from each end
3	3: at center and at points 1/6 the length of the open face from each end
2	2: at points 1/4 the length of the open face from each end
1	1: at center

7.1.2 Placement of the Test Specimen

The specimen is placed in the testing machine frame as shown in Figure 18. It is supported by means of lengths of channel iron. These pass beneath the legs and rest on crossbars of the main testing machine frame. One end of each of the channel iron supports should be attached to a crossbar with a U-bolt. If the specimen has a center leg, it should also be supported.

In practice, the specimen is first positioned symmetrically beneath the center load head and the load frames on either side and they are then adjusted so that the load heads contact the seat cushions at the proper points lengthwise of the specimen. Ordinarily, the specimen rather than the load frame is adjusted to obtain the proper front to back position of the specimen.

Vertical positioning of the specimen may be obtained by adjusting the height of the crossbars supporting the channel iron supports. The load heads should just clear the surfaces of the seats when the air cylinders are fully retracted. Overall positioning of the specimen should be such, however, that the underside of the specimen may be readily inspected from below while a test is in progress.

7.1.3 Test Procedures

Testing of the specimen is begun with 100 pounds of force applied to the rear position of the load head and with 50 pounds applied to the front position. The dead weight of the load frame and load head at the front and rear points is added to that of the force applied by the air cylinders at the same points to obtain the forces applied to the specimen. Rear forces are increased in increments of 25 pounds and front forces in increments of 12.5 pounds after 25,000 cycles have been completed at each preceding force level. The specimen is carefully re-examined for damage each time an additional 25,000 cycles has been completed.

Tests are continued until some type of seat foundation failure such as breakage of a spring occurs, until some type of frame failure occurs, or until a desired level of performance has been achieved.

7.2 Backrest Foundation and Backrest Frame Test

7.2.1 Summary of the Test Method

The test consists of applying one or more forces, depending on the type of specimen (i.e., number of seating positions), to the backrest of the specimen in a front to back direction. These forces are applied at the midpoint of each seating position, determined as follows:

No. of Seating Positions	Force Application Points
4	4: at points 1/8 and 3/8 the length of the open face from each end
3	3: at center and at points 1/6 the length of the open face from each end
2	2: at points 1/4 the length of the open face from each end
1	1: at center

In the case of the backrest foundation tests, point of contact of the center of the load heads with the backrest surface is 9 inches above the point of intersection of the backrest with the seat surface. The line of action of the load frame is inclined downward at an angle of 12.5 degrees with the horizontal.

For the backrest frame test, the center of the load head is 16 inches above the point of intersection of the surface of the backrest with the surface of the seat; this provision is subject to the constraint that the force may not be applied at a point higher than one inch below the top surface of the top rail. Angle of inclination of the load frame for this test is zero degrees.

7.2.2 Placement of the Test Specimen

The specimen is placed in the testing machine frame as shown in Figure 19 for the backrest foundation test and as shown in Figure 20 for the backrest frame test. A length of 3/4-inch diameter pipe is placed crossways behind the rear legs of the specimen, Figure 20, to keep the specimen from sliding backwards. This pipe in turn is held in place by short lengths of 2-inch diameter pipes which are attached to members of the testing machine frame itself by means of scaffolding clamps, Figure 20. Pipe hold-downs are used, Figure 19, to keep the specimen from overturning as the forces are applied to the backrest. These hold-downs are attached to a pipe which is placed crossways in front of the specimen and which in turn is attached to the main machine frame. If the legs of the specimen have a tendency to jump over the pipe stop, hold-downs may also be applied to the tops of the arms near the rear of the specimen. It is important that these hold-downs do not restrain the specimen in the front to back direction as forces are applied during the back test; i.e., the hold-downs should be adjusted so that the front end of the specimen does not lift off the floor, but the specimen should still be able to slide freely beneath them.

Overall height of the total load frame is adjusted by raising or lowering the 2-inch diameter swivel column sleeve bearing which attaches the swivel column to the main testing machine frame. Lengthwise adjustment of the frames is also effected by adjusting this sleeve. Front to back adjustment of the specimen with respect to the load heads is accomplished by adjusting the position of the pipe leg stop which passes crossways behind the back legs of the specimen. Ordinarily, the specimen should be positioned so that there is a slight amount of clearance between the backrests and the load heads when the air cylinders are fully retracted.

7.2.3 Test Procedures

7.2.3.1 Backrest Foundation Test (Figure 19)

The test is begun at the 50 pound force level. Forces are increased in increments of 12.5 pounds after 25,000 cycles have been completed at each previous force level. Testing is continued until some type of physical failure occurs in the backrest foundation system such as a broken spring or until a desired level of performance has been achieved.

7.2.3.2 Backrest Frame Test (Figure 20)

The test is begun at the 75 pound force level. Forces are increased in increments of 25 pounds after 25,000 cycles have been completed at each preceding force level. Testing is continued until the frame suffers disabling damage or until a desired level of performance has been achieved.

To carry out this test, an L-shaped pipe frame constructed of a 6-inch length and a 36-inch length of 1-1/4-inch diameter pipe coupled together with an elbow is attached to one leg of the external backrest load frame by means of a scaffolding clamp, Figure 20. The long leg of the L-shaped frame rests on the top rail of the backrest of the specimen. Its purpose is to maintain the load frame at the proper elevation for testing of the backrest frame. Specifically, the support leg of the frame should be adjusted so that the center of the load head is 16 inches above the point of intersection of the surface of the backrest with the surface of the seat or one inch below the top surface of the top rail, whichever is lower.

In the event that the backrest frame is damaged during the backrest foundation tests, it will be necessary to use a new specimen for this test. It is also permissible to use a new specimen in the backrest frame test regardless of whether or not observable damage has occurred during the backrest foundation test. Also if a leg should break before the backrest tests are completed, a substitute leg may be clamped to the specimen frame and testing continued.

In the event that the backrest frame is not damaged during the backrest foundation tests, a portion of the force cycles completed during that test may be applied to the backrest frame test. Specifically, testing may be started in the backrest frame test (on the same specimen used in the backrest foundation test) at the nearest backrest frame force level below the last force level achieved in the backrest foundation test.

As an alternative to the procedure described above, the Cyclic Front to Back Force Test on Top Rails specified in The Performance Test Method For Upholstered Furniture (3) may be used as a substitute for the backrest frame foundation test in this specification.

7.3 Horizontal Sidethrust Arm Load Test (Figure 21a, 21b)

7.3.1 Summary of the Test Method

The cyclic horizontal outward thrust load test for arms consists of subjecting one arm of the specimen to a horizontal force in an outward direction applied to the inside surface of the arm. This force is applied as near as possible to the point of intersection of the stump with the arm.

7.3.2 Placement of the Test Specimen

The specimen is placed in the testing machine as shown in Figure 21a. A 3/4-inch diameter crossbar which is supported by the main testing machine frame is butted up against the legs at the end of the specimen being tested. This crossbar acts as a backstop which prevents the specimen from sliding when forces are applied to the arm. Pipes which run parallel to the length of the specimen are placed immediately in front of and behind the specimen at a height of a few inches above the floor. These pipes prevent the specimen from slipping from front to back or vice versa during the course of the test but yet allow it to slide freely endways. Vertical uprights about 18 inches long are attached to these pipes at one end of the specimen to provide a backstop for the 3/4-inch diameter pipe leg stop. In the event the rear leg is offset with respect to the front leg, it may be necessary to use an individual leg stop for each leg. Hold-downs may be needed to prevent the legs from jumping over the leg stop. Hold-downs also may be used at the other end of the specimen to prevent that end from rising when force is applied to the arm.

Sidethrust forces may be applied to an arm by means of one of the backrest load frames used in the backrest load tests. To hold the load frame in position, an L-shaped pipe frame constructed of 1-1/4-inch diameter pipe is attached to one leg of the external backrest load frame by means of a scaffolding clamp. The long leg of the frame rests on top of the arm of the specimen. This support frame should be adjusted in height so that the center of the load head contacts the arm at a point as near as possible to the intersection of the longitudinal axis of the arm with longitudinal axis of the stump. Forces are applied in one direction only in this test so that the cylinder is not retracted during the off cycle.

7.3.3 Test Procedures

A single force is applied at a point which corresponds to the intersection of the longitudinal axis of the arm with the longitudinal axis of the stump, Figure 21b. The legs at the end of the specimen are blocked with a 3/4-inch diameter pipe, Figure 21a.

Testing is started at the 50 pound force level; forces are increased in increments of 25 pounds after 25,000 cycles have been completed at each force level. The test is continued until the arm suffers disabling damage or until a desired level of performance is reached. If a leg should break during the test, a substitute leg may be clamped to the specimen frame and the test continued.

As an alternative to the above procedure, the Cyclic Load Test for Arms --Outward may be carried out on a bare frame in accordance with the procedures outlined in The Performance Test Method for Upholstered Furniture (3), Test for Arms --Outward.

7.4 Sidethrust Load Test on Legs (Figure 22a, 22b)

7.4.1 Summary of the Test Method

The method consists of applying a sidethrust force to one end of a specimen in an inward direction which is resisted by the legs at the opposite end. Usually, the force can be applied to a side rail. It should be applied in a direction parallel to the floor and perpendicular to the longitudinal axis of the side rail at a point on the side rail midway between the front and back legs. The specimen is prevented from sliding endways by means of a pipe stop which butts up against the legs at the other end of the specimen. This pipe stop applies floor reaction forces to the legs in the inward direction so that the desired force is applied to the legs.

7.4.2 Placement of the Test Specimen

The specimen is placed in the testing machine as shown in Figure 22a. A 3/4-inch diameter crossbar is butted up against the legs at the end of the specimen being tested. This crossbar acts as a backstop which prevents the specimen from sliding when forces are applied to the end of the specimen and also applies sidethrust forces to the legs. Pipes which run parallel to the length of the specimen are placed immediately in front of and behind the specimen at a height of a few inches above the floor. These pipes prevent the specimen from slipping out of line during the course of the test but yet allow it to slide freely endways. Vertical uprights about 18 inches long are attached to these pipes at one end of the specimen to provide a backstop for the 3/4-inch diameter pipe leg stop. In the event the rear leg is offset with respect to the front leg, it may be necessary to use an individual leg stop for each leg. Hold-downs may be attached to the front and back pipes which run parallel to the length of the specimen to prevent the legs from jumping over the leg stop.

One of the backrest load frames may be used to apply sidethrust forces to the specimen. The position of the load head and load frame should be adjusted so that the force is applied perpendicular to the side of the side rail at a point which corresponds approximately to one half the distance from the front to the back legs, Figure 22a, so that the force is shared equally by the front and back legs.

7.4.3 Test Procedures

A single force which acts parallel to the length of the specimen is applied to a side rail at one end of a specimen at a point which corresponds approximately to a position midway between the front and back legs, Figure 22b. The legs of the specimen at the opposite end of the specimen are blocked with a 3/4-inch diameter pipe in such a way, Figure 21a, that the legs are loaded by the pipe in an inward direction.

The test is begun at the 200 pound force level. Forces are increased in increments of 50 pounds after 25,000 cycles have been completed at each previous force level. Testing is continued until a leg or the frame suffers disabling damage or until a desired level of performance has been achieved.

This test may be carried out on a specimen which has been used in previous tests, or it may be carried out on a new, i.e., untested, specimen. In addition, the Cyclic Sidethrust Load Test on Legs specified in The Performance Test Method for Upholstered Furniture (3) may be used to satisfy the side-thrust leg test specified in this document.

7.5 Front to Back Load Test for Legs (Figure 23a, 23b)

7.5.1 Summary of the Test Method

The test consists of applying a force to the front rail of a specimen in a front to back direction. This force is applied at one end of the specimen, preferably near one of the front rail to side rail joints. Line of action of the force is parallel to the floor and perpendicular to the longitudinal axis of the front rail.

The action of this force is resisted by a crossbar which is placed crossways behind the rear legs of the specimen. This bar prevents the specimen from sliding backwards when a front to back force is applied to the front rail and simultaneously applies the desired floor reaction force to one leg.

7.5.2 Placement of the Test Specimen

The specimen is placed in the testing machine frame as shown in Figure 23a. A length of 3/4-inch diameter pipe is placed crossways behind the rear legs of the specimen in a manner identical to that shown in Figure 20 to keep the specimen from sliding backwards. It is mandatory that a 3/4-inch diameter pipe be used since it ensures that the reaction force will be applied to the legs at points 1/2 inch above the floor. This pipe in turn is held in place by short lengths of 2-inch diameter pipes which are attached to members of the testing machine frame itself by means of scaffolding clamps, Figure 20. Pipe hold-downs may be used to keep the specimen from overturning. If the legs of the specimen have a tendency to jump over this pipe stop, hold-downs may be applied to the tops of the arms near the rear of the specimen. It is important that these hold-downs do not restrain the specimen in the front to back direction as force is applied during the test; i.e., the hold-downs should be adjusted so that the front end of the specimen does not lift off the floor or the back legs jump over the crossbar backstop, but the specimen should still be able to slide freely beneath the hold-downs.

One of the backrest load frames may be used to apply forces to the front rail. Overall height of the load frame is adjusted by raising or lowering the 2-inch diameter swivel sleeve bearing which attaches the pivot column to the main testing machine frame. Sideways adjustment of the frames is also effected by adjusting this sleeve. Front to back adjustment of the specimen with respect to the load heads is accomplished by adjusting the position of the pipe leg stop which passes crossways behind the back legs of the specimen. Ordinarily, the specimen should be positioned so that there is a slight amount of clearance between the backrests and the load heads when the air cylinders are fully retracted.

7.5.3 Test Procedures

Testing is begun at the 150 pound force level. Forces are increased in increments of 50 pounds after 25,000 cycles have been completed at each preceding force level. Testing is continued until the specimen frame or leg suffers disabling damage.

The load frame is adjusted so that force is applied parallel to the floor near the end of the rail in a front to back direction, Figure 23b. Load heads are not retracted on the OFF cycle. Should the load heads have a tendency to slide sideways during the course of the test, it may be clamped to the front rail.

A new specimen may be used in this test if desired. Also, the Cyclic Front to Back Leg Test on Legs as specified in The Performance Test Method for Upholstered Furniture (3) may be used to satisfy the back leg test requirement in this specification.

7.6 Force levels, including acceptance levels, for all of the above tests are summarized in Table 1. Force increments to be used are given in Table 2.

7.7 Fold Out Bed and Mattress Operating Durability Test (Figures 24 through 26)

This test is applicable only to dual purpose (seating/sleeping) units.

7.7.1 Summary of the Test Method

The cyclic fold-out fold-in test for sleeper specimens, to be performed after the tests specified in 7.1 through 7.5, consists of subjecting the specimen to a complete opening and closing of the bed unit. After every 250 cycles have been performed, the unit shall be checked for wearing of joints and/or rivets, along with the measurement of clearances.

7.7.2 Test Procedures

A test device shall be attached to the middle of the spring front bar which will exert a push-pull action to completely fold out and fold into the dual-purpose item. The device shall operate at 10 cycles per minute. One cycle consists of a push-pull stroke.

Light-service acceptance level:	1,500 cycles
Medium-service acceptance level:	2,000 cycles
Heavy-service acceptance level:	2,500 cycles

The manufacturer shall state the mattress and fold out bed mechanism brands and model numbers used in the specimen being tested. Measurements must be taken every 250 cycles until failure or desired level of testing is achieved to determine if any excessive wear has occurred on any joint. This shall be done by completing a visual/manual examination of all joints and/or rivets and measurement of clearances as listed below.

VISUAL/MANUAL CHECKS. During the visual/manual examination, there shall be checks for the following problems:

- Loosening of joints and/or rivets
- Rubbing of joints and/or rivets
- Excessive wear on any member
- Wearing or bending of bed mechanism causing it to hit the bed frame

CLEARANCE CHECKS. Before, during and after testing, the specimen shall maintain the following minimum clearances:

Breast rail clearance (Figure 24)	1/4 inch minimum
Front rail clearance (25A, 25B, Figure 25)	1/4 inch minimum to unfinished rail; 1/8 inch minimum to finished rail
Floor clearance with specimen in fully closed position (Figure 26)	1/4 inch minimum

Any evidence of one or more of the above problems or failure to maintain stated minimum clearances constitutes a failure of the test and shall be noted in the test report form. The report form shall also be used to indicate passing results for the fold out bed and mattress operating durability test.

7.8 Recliner Tests

This test is applicable only to recliner chairs.

7.8.1 Recliner Cycling Test

7.8.1.1 Summary of the Test Method

The specimen shall first be subjected to the tests specified in 7.1 through 7.5, with the exception that when running the Backrest Foundation Test (7.2), the ottoman shall be secured with a strap around the recliner, restraining the ottoman from opening and keeping the back in an upright position.

7.8.1.2 Cycling Test

A weight of 200 lbs. shall be applied while testing is being performed (150 lbs. in the seat, 50 lbs. attached to the center of the front of the backrest). A mark, represented by the line at A in Figure 27a, shall be placed on the backrest and the arm to monitor any back looseness. A cycle shall consist of the recliner in the closed position, extended to the T.V. position and then extended to full recline and then back to fully closed. This is shown in sequence of Figures 27a, 27b, 27c, and then Figures 27c, 27b, 27a. Cycle the recliner 25,000 cycles or to failure, whichever occurs first. After every 2,000 cycles and at the end of the test, a visual examination of the recliner and ottoman mechanism shall be conducted checking for the following problems:

- Loosening of joints and/or rivets
- Rubbing of joints and/or rivets
- Excessive wear on any member
- Wearing or bending of recliner mechanism causing it to hit the frame

Any evidence of one or more of the above problems constitutes a failure of the test and shall be noted in the test report form. The report form shall also be used to indicate passing results for this cycling test.

7.8.2 Ottoman Test

The recliner ottoman shall be extended in the out position, as shown in Figure 27c. A 75 lb. weight shall be dropped from a height of 3 inches above the ottoman. The test shall be repeated at increasing heights, as shown below, through 12 inches. After each drop, the ottoman is returned to the enclosed upright position and the recliner is checked for damage. This constitutes one cycle.

<u>HEIGHT OF DROP</u>	<u>WEIGHT</u>
3 inches	75 lbs.
6 inches	75 lbs.
9 inches	75 lbs.
12 inches	75 lbs.

EQUALS ONE CYCLE

This test shall be performed 20 times (20 cycles). After each cycle and at the end of the test, a visual examination of the recliner and ottoman mechanism shall be conducted checking for the following problems:

- Loosening of joints and/or rivets
- Rubbing of joints and/or rivets
- Excessive wear on any member
- Wearing or bending of ottoman mechanism causing it to rub or hit the frame or recliner

Any evidence of one or more of the above problems constitutes a failure of the test and shall be noted in the test report form. The report form shall also be used to indicate passing results for the ottoman test.

8.0 Reporting of Tests

Upon completion of each test, the official report (Form A) shall be completely filled out and sent with the 4 x 5- inch photographs requested to the GSA Contracting Officer listed in the solicitation. The report shall contain the following information:

8.1 A complete description of the specimen including the manufacturer's name and model number, a photograph of the specimen, a list of materials, and general construction details. Any differences between the specimen tested and the product to be offered for bid shall be clearly noted. In particular, differences in materials and details of construction shall be clearly outlined.

8.2 A description of the test performed including photographs of the test equipment used. Any differences between the equipment used and the equipment described in this document shall be clearly noted.

8.3 A complete description of the nature of the failure that occurred including photographs of the entire specimen and of the area in which the failure occurred.

8.4 The force level and the number of cycles completed at that force level at the time failure occurred.

8.5 The last force level at which the specimen successfully completed 25,000 cycles.

8.6 Any other relevant information about the testing process which might be useful in determining exactly why the specimen performed as it did.

8.7 The signatures and corporate titles of the personnel performing the tests and of the officer of the manufacturer certifying the validity of the test results.

References

1. British Standards Institution. 1975, BS4875. Strength and stability of domestic and contract furniture. London.
2. Eckelman, C.A. 1978. Strength design of furniture. Tim Tech, Inc., Box 2198, W. Lafayette, Ind.
3. Federal Supply Service, 1978. The performance test method for upholstered furniture, FEHS-78-125. General Services Administration, Washington, D.C. (See also: Eckelman, C.A. and J.E. Winandy, 1979. Performance Tests for Furniture Frames. International Journal of Furniture Research 1(6,7):6pp).
4. Society of Automotive Engineers, 1981. SAE motor vehicle seating manual - SAE J782. Warrendale, PA.
5. USDA Forest Service, Forest Products Laboratory, 1974. Wood handbook. USDA Agri. Handbook. 72. Madison, Wis.

Organizations or Manufacturers Referenced

1. American National Standards Institute, 11 West 42nd Street, New York, NY 10036.
2. National Fluid Power Association, 3333 N. Mayfair Road, Milwaukee, WI 53222-3219.

TABLE 1. Summary of load tests. All force figures are in Pounds; acceptance levels are shown in bold and are identified as Light (L), Medium(M) or Heavy (H).

# cycles (x 1000) at each force level		25	25	25	25	25	25	25	25	25
# cumulative cycles (x 1000)		25	50	75	100	125	150	175	200	225
TEST						FORCE	LEVEL			
Seat load test (7.1)	Back	100	125	150	175	200	225	250	275	
	Front	50	62.5	75	87.5	100 L	112.5	125 M	137.5 H	
Backrest foundation test (7.2.3.1)		50	62.5	75	87.5	100	112.5 L	125 M	137.5	150 H
Backrest frame test (7.2.3.2)		75 L	100 M	125	150 H					
Sidethrust load test-arm (7.3)		50	75 L	100	125	150 M	175	200 H		
Sidethrust load test-leg (7.4)		200 L	250 M	300	350 H					
Front to back load test for legs (7.5)		150 L	200 M	250	300 H					

TABLE 2. Summary of force increments.

Test	Force increment per cylinder (lbs.)
Seat load test (7.1)	25 / 12.5 (back/front)
Backrest foundation test (7.2.3.1)	12.5
Backrest frame test (7.2.3.2)	25
Sidethrust load test-arm (7.3)	25
Sidethrust load test-leg (7.4)	50
Front to back load test for legs (7.5)	50

FORM A - Report of Upholstered Furniture Performance Test

Date of completion of test _____

Manufacturer _____ Mfr. 's model no. _____

Materials used in specimen

Type and details of spring/support system

Seat: _____

Back: _____

Joint construction details

Name of test performed (submit photograph of test set-up with specimen in place taken before start of test)

Description of failure (submit photo of entire specimen after failure and a close-up photo of the area of failure)

Load level at failure _____

No. cycles completed at load level producing failure _____

Last successful load level _____

Other relevant information

Name of testing laboratory _____

Laboratory technician (name) _____ (title) _____

Certified by (name) _____ (title) _____

FIGURES 1 through 27c.



Figure 1. Typical main testing machine framework in which the specimens are placed for testing.

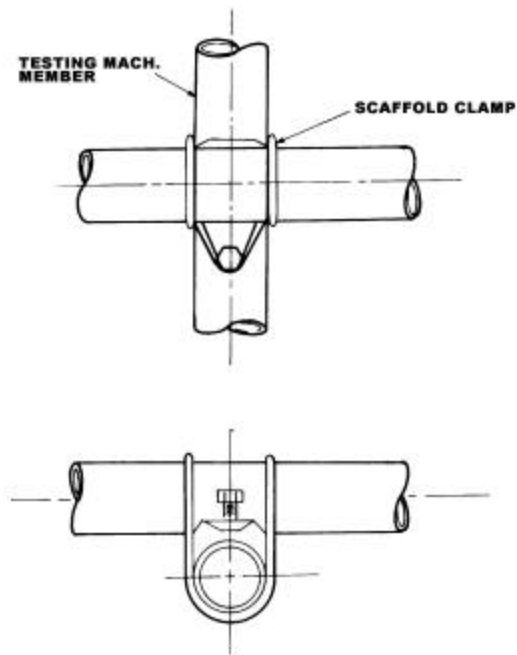

Figure 2. Scaffolding clamps which are used to join the various members together to form the main testing machine frame and which are also used to connect the various jigs and fixtures needed in the tests to the main machine frame.

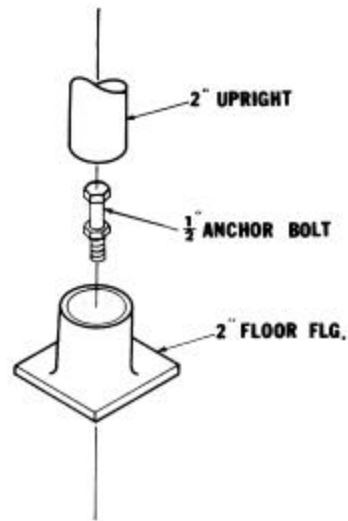

Figure 3a. Special floor flange which may be used to attach the main testing machine frame to anchors embedded in a concrete floor.

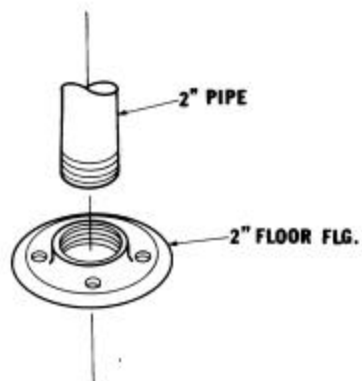

Figure 3b. Standard pipe floor flange which may be used to anchor the main testing machine frame to the floor.

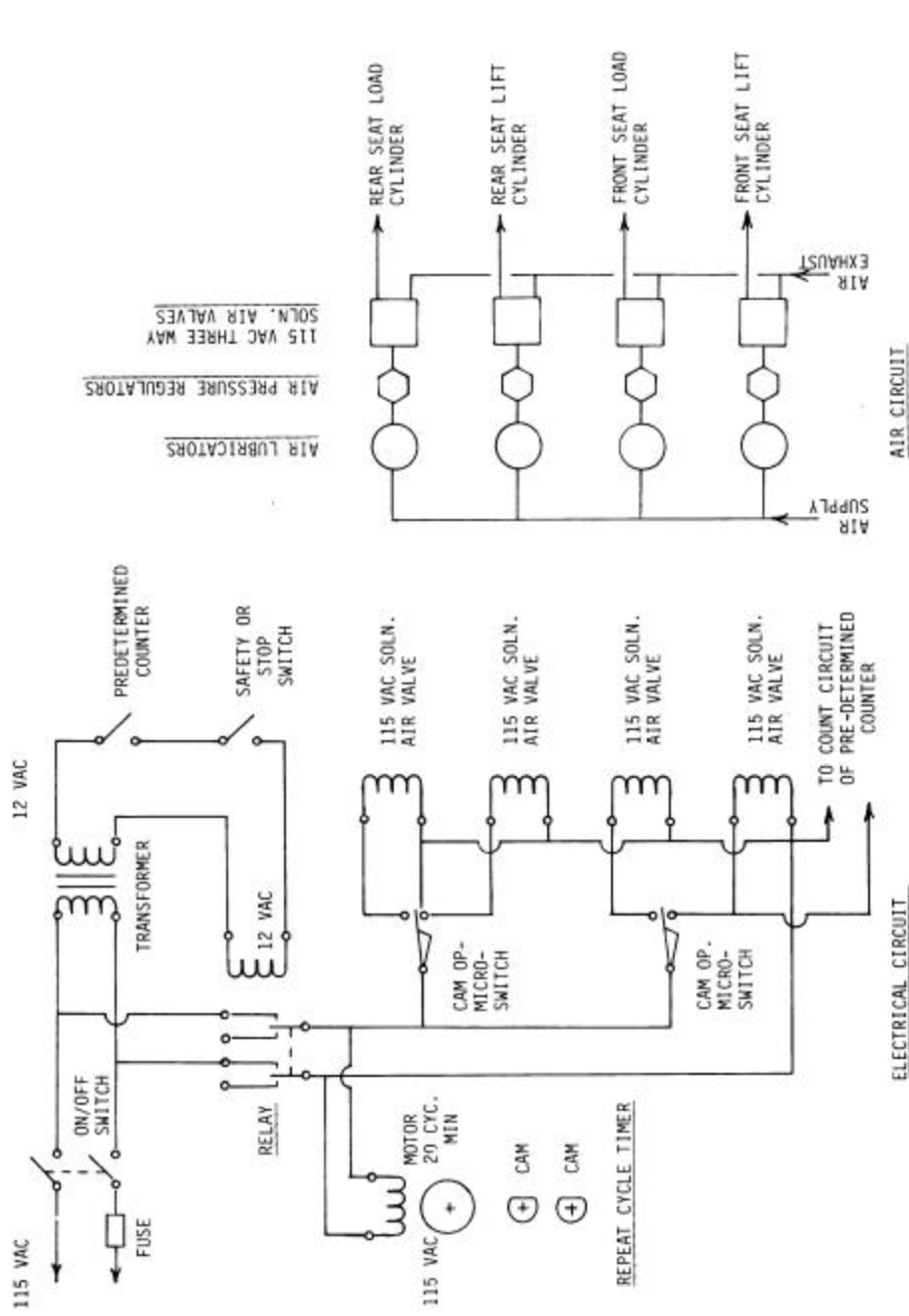

Figure 4. Typical air and electrical circuit used to control the tests.

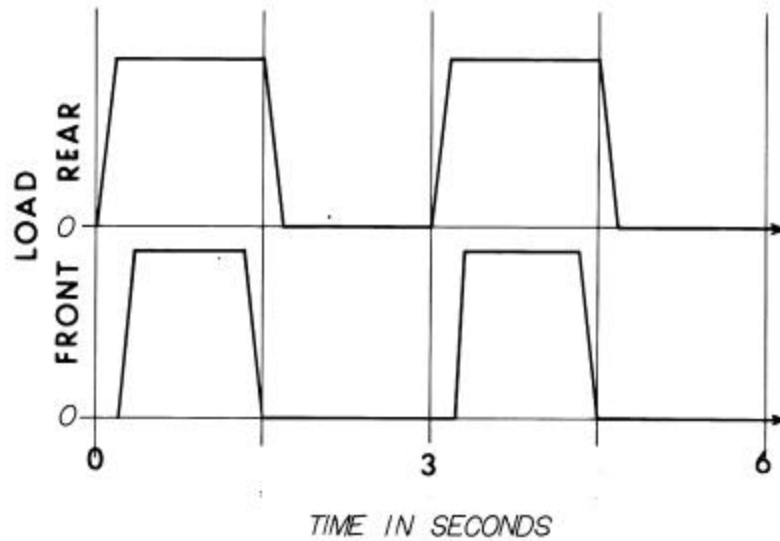

Figure 5. Graphic portrayal of a typical load cycle. Strict adherence to force relationships portrayed by the curve is not required; however, the load should reach its maximum value for at least half of each load cycle and should be zero for at least half of the unload cycle. The rear seat load sequence is shown at top in the drawing; the front seat load sequence is shown below.

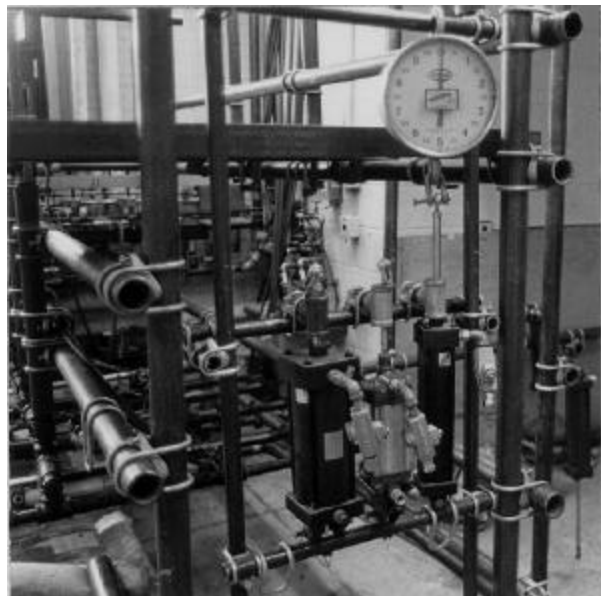

Figure 6. Force calibration assembly. Spare cylinders have been mounted in the frame to simplify the calibration procedure. Note that speed control valves have been installed in the inlet air port of each air cylinder.

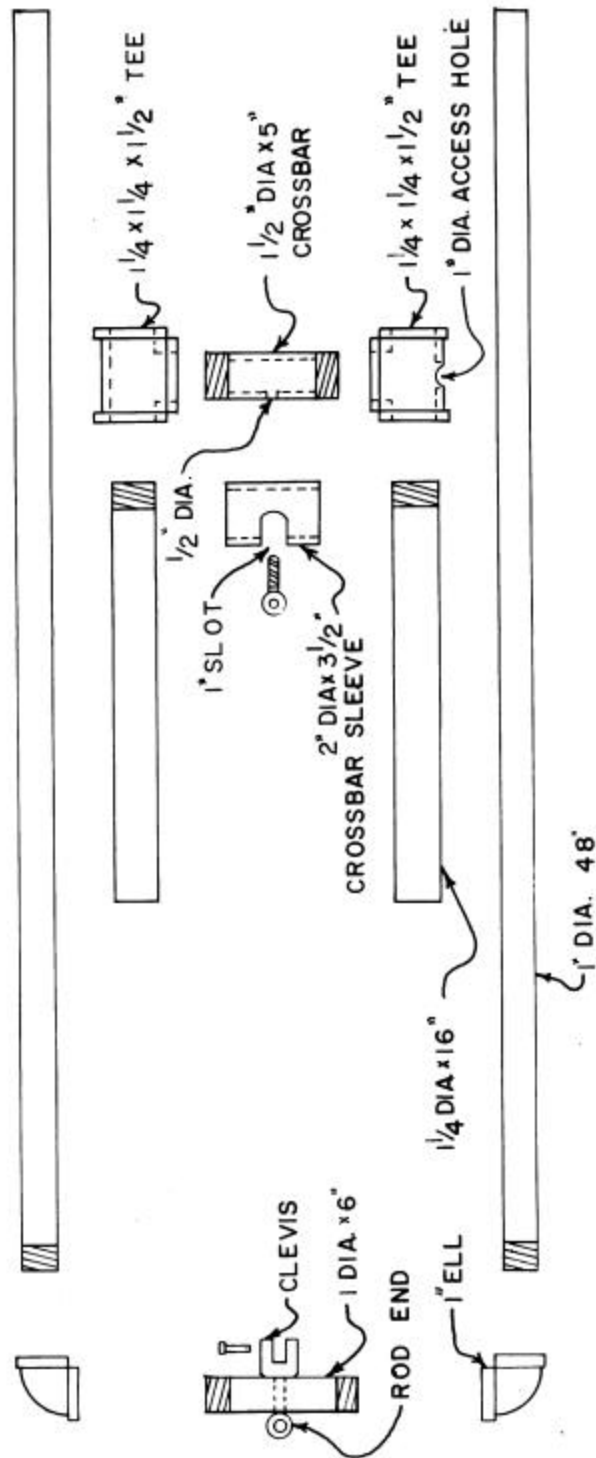

Figure 7a. Exploded view of typical load frame used in the seat load tests.



Figure 7b. The load frames are attached to the main testing machine frame as shown here.



Figure 7c. The crossbar sleeve is rigidly attached to the main testing machine frame. The rod end fits through a slot cut through the sleeve and threads into a nut inside of the internal crossbar. The 1" access hole for the nut can be seen in the side of the Tee.

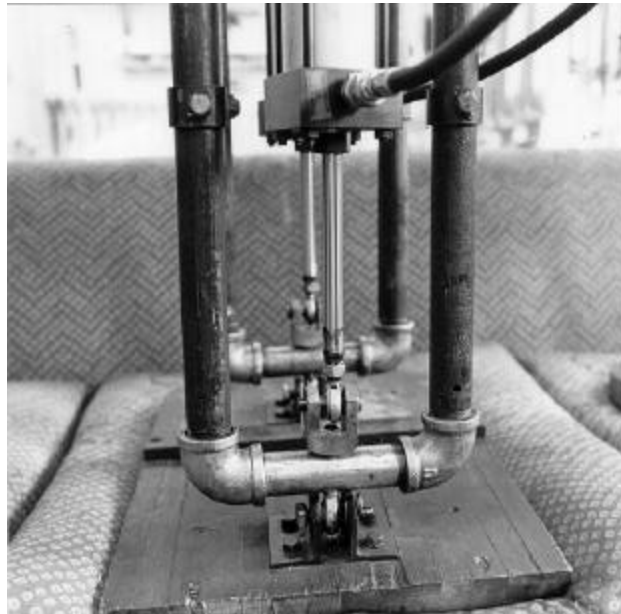

Figure 8. Two load frames are attached to each load head. The front frame is attached to the load head at a point 2 inches from the front edge, whereas the rear load frame is attached as a point 13-3/8 inches from the front edge. The load heads are attached to the load frames by means of clevises and rod ends.

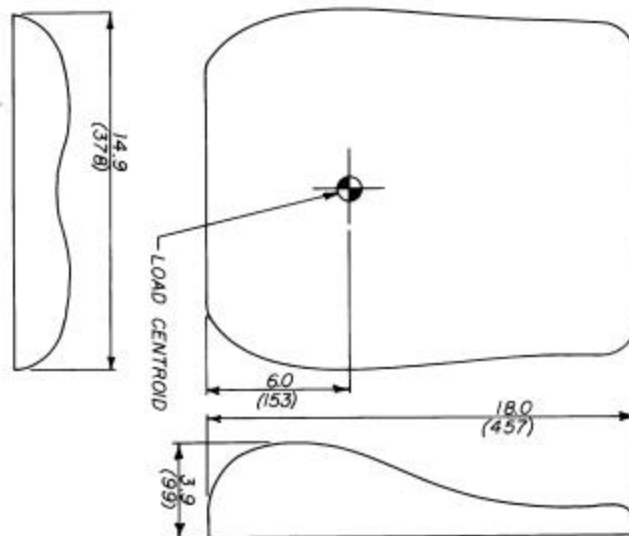

Figure 9. Configuration of the seat load head used in the seat load tests. Dimensions are given in inches and centimeters.

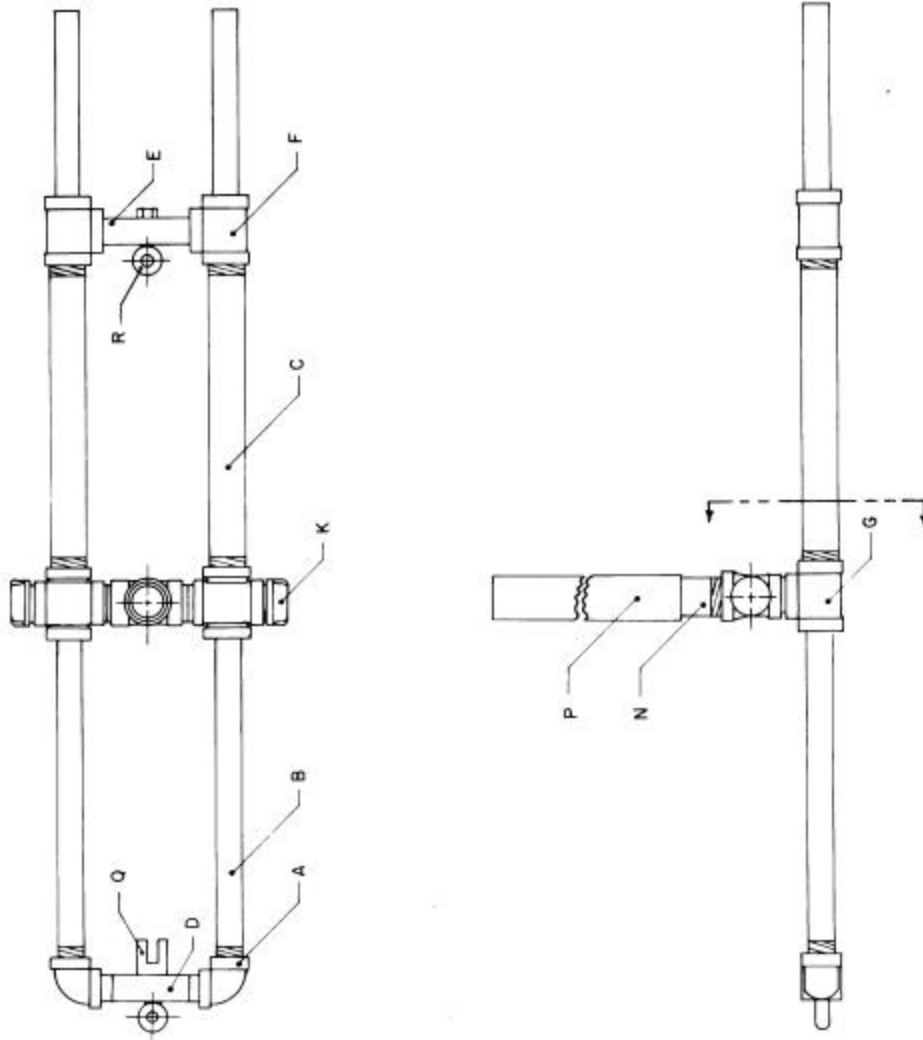

Figure 10. View of typical backrest load frame. Symbols: A, 1" Ell; B, extension shaft, 1" x 48"; C, extension shaft sleeve bearing, 1-1/4" x 16"; D, crossbar, 1" x 6"; E, crossbar, 1" x 5-1/2"; F, reducing Tee, 1-1/4" x 1"; G, Tee, 1-1/4" x 1"; H, close nipple, 1-1/4"; I, close nipple, 1-1/4"; J, end cap, 1-1/4"; K, end cap, 1-1/4"; L, expansion Tee, 1-1/4" x 1-1/2"; M, expansion Tee, 1-1/4" x 1-1/2" x 20"; N, swivel column, 1-1/2" x 20"; P, swivel column sleeve bearing, 2" x 18"; Q, clevis; R, clevis.



Figure 12. The vertical external 2 inch diameter swivel sleeve bearing provides a means of attaching the backrest load frame to the main testing machine frame. The inner 1-1/2 inch diameter swivel column is free to rotate within the external sleeve bearing. This allows the backrest load frame to swivel from side to side as well as pivot up and down. As a result, the load frame is able to follow complex movements of the backrest as it deflects under load.



Figure 11. Crossed Tees attached to the free ends of the extension shaft sleeve bearings in the external load frame together with a Tee attached to the lower end of the vertical swivel support column and a one inch diameter cross shaft or hinge pin which passes through them to form a hinge which allows the backrest load frame to pivot up and down.



Figure 14. The clevis bracket attached to the rear end of the air cylinder provides a means of attaching the body of the cylinder to the crossbar of the external load frame. A strap which is bolted to the crossbar by means of the rod end body and nut provides a point of attachment for a spring/turnbuckle/chain linkage which controls the angle of inclination of the test load frame.

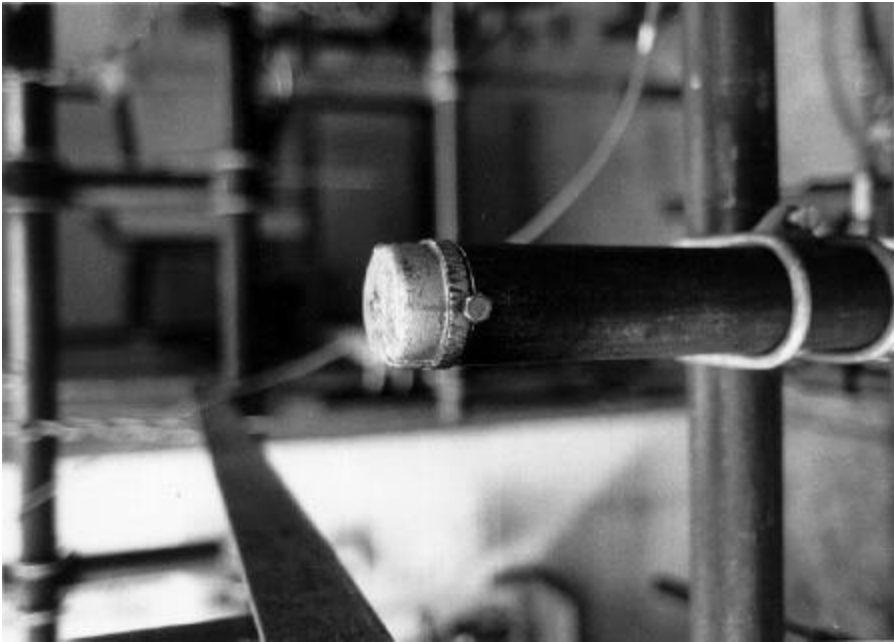

Figure 13. A pin, which passes crossways through the 1-1/2 inch diameter swivel support column, rests on a shallow v-groove filed into the top edge of the 2 inch diameter external sleeve. Weight of the load frame acting on the pin causes the pin to index in the bottom of the groove and thus align the frame into the correct starting position each time the load retracts.

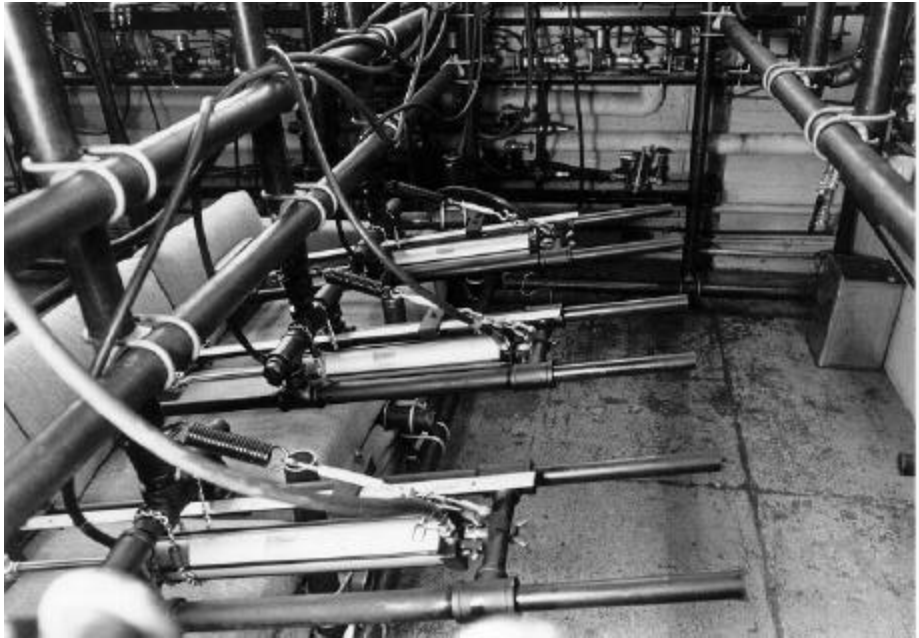

Figure 15. The linkage used to control the inclination of the load frames consists of a spring, turnbuckle, and length of chain. The spring is attached to an eyebolt which passes through the lower end of the 1-1/2 inch diameter swivel support column. The other end of the linkage, the chain, is attached to a strap which is bolted to the external crossbar.



Figure 16. A clevis type bracket attached to the rear of the load head provides a means of attaching the load head to the crossbar of the internal load frame. Position of the cross hole in this bracket controls the amount of movement of the load head both up and down and side to side. A male rod end to which the load head is attached passes through the cross bar of the internal load frame and threads into the body of a clevis.

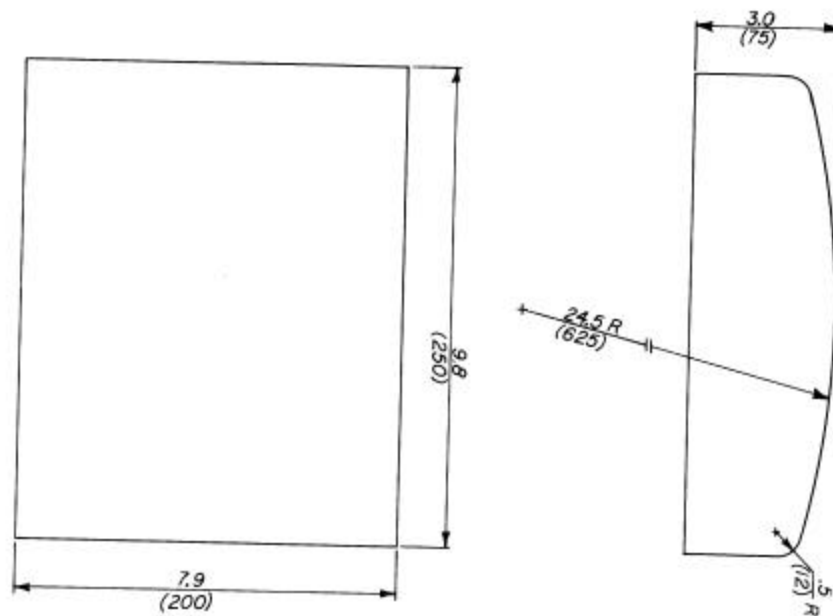

Figure 17. Configuration of the backrest load head. Dimensions are given in inches and millimeters.

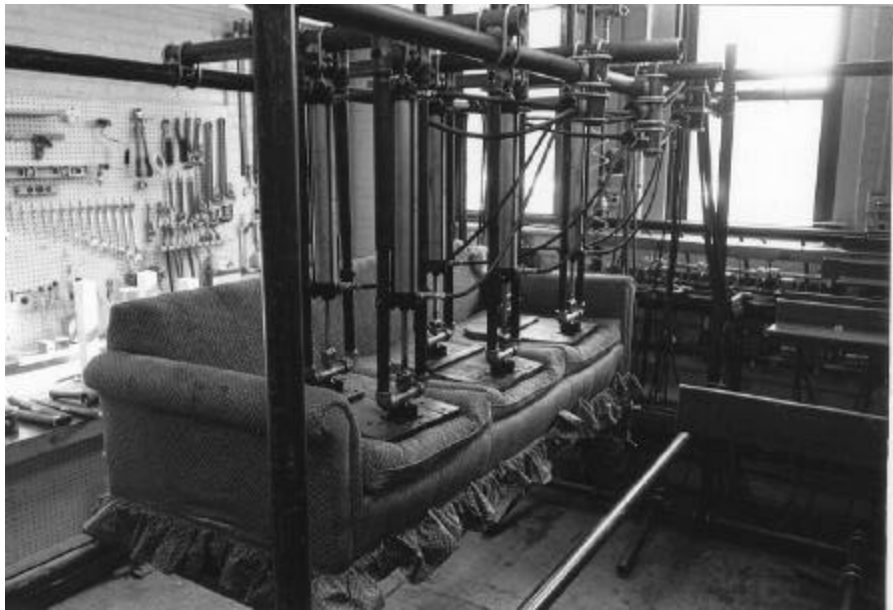

Figure 18. A sofa is arranged for testing in the main testing machine frame as shown here. Lengthwise, loads are applied at the center and at points 1/6 the length of the open face of the sofa from each end. Front to back, the frame is arranged so that the front edges of the load heads are aligned evenly with the front edge of the sofa.

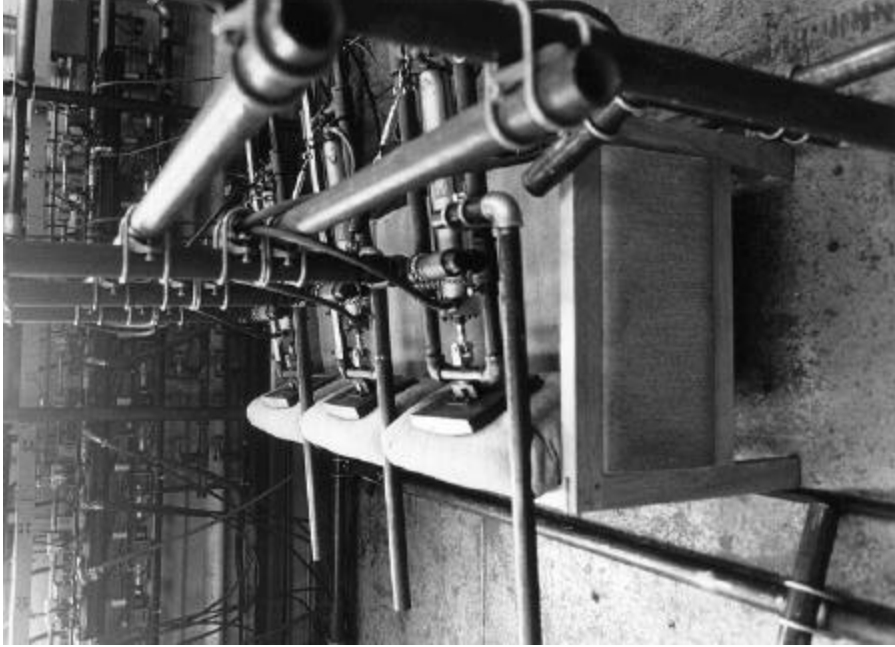

Figure 20. Placement of the sofa in the main testing machine frame for the backrest frame test. A length of 3/4 inch diameter pipe placed behind the back legs of the sofa prevents the sofa from sliding backwards during the test. Construction of the L-shaped pipe frames used to hold the load heads in the proper position for the backrest frame test can also be seen here.



Figure 19. Placement of the sofa in the main testing machine frame for the backrest foundation tests. A length of 3/4 inch diameter pipe placed behind the back legs of the sofa prevents the sofa from sliding backwards during the test.

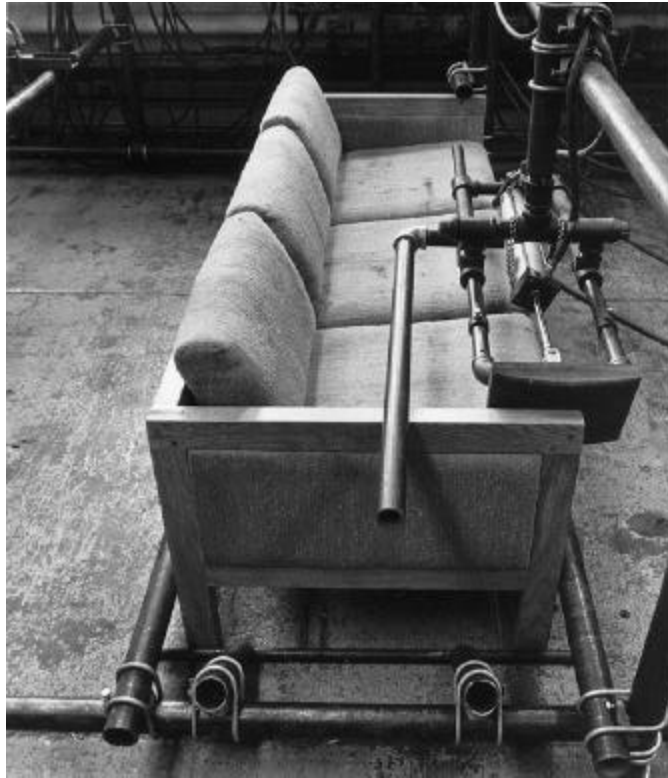

Figure 21a. The sofa is held in place for the horizontal sidethrust load test on arms as shown here. A 3/4 inch diameter pipe stop is used to prevent the sofa from sliding.

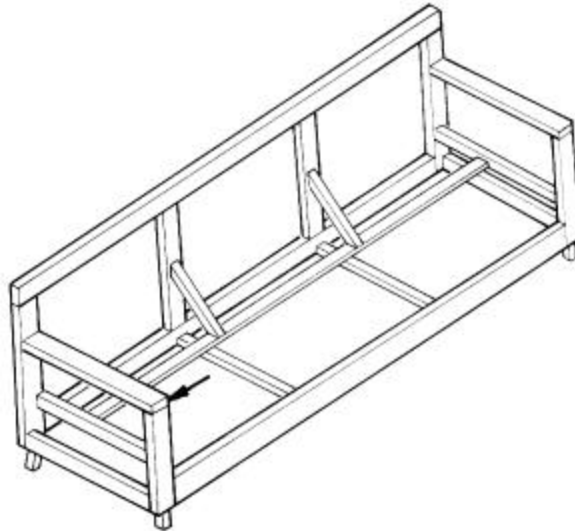

Figure 21b. Diagram showing point of application of load to the frame for the horizontal load test on arms.

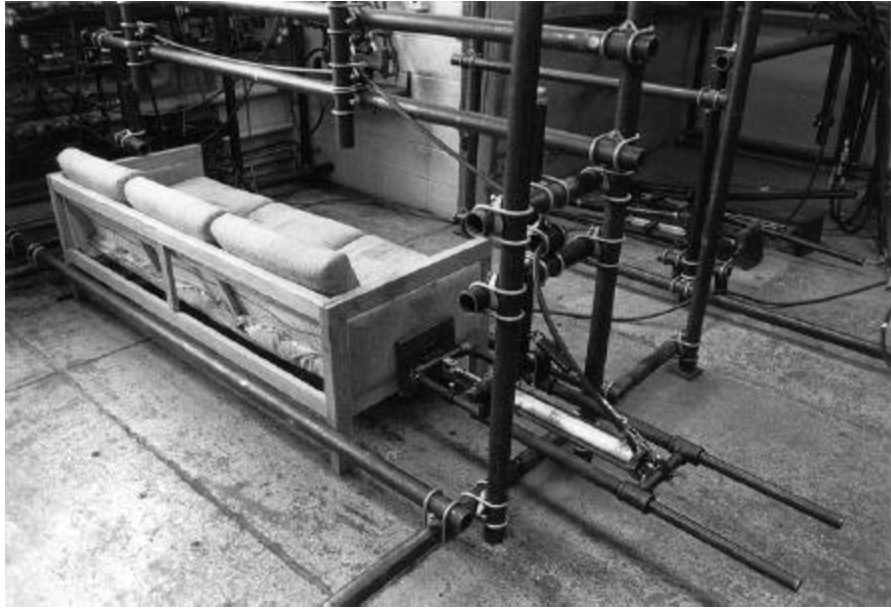

Figure 22a. The load frame and load head are positioned as shown here for carrying out the sidethrust load test on legs. The legs are braced in the same manner as for the sidethrust load test on arms, Figure 21.

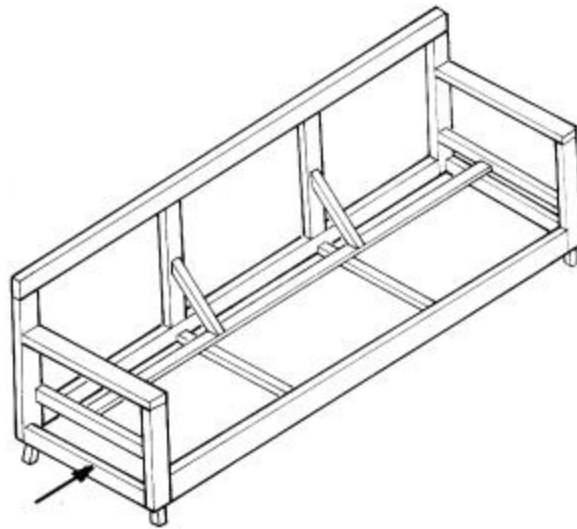

Figure 22b. Diagram showing point of load application for sidethrust load test on legs.



Figure 23a. Arrangement of a sofa in the main testing machine frame for carrying out the front to back load test for legs. A length of 3/4 inch diameter pipe placed behind the back legs of the sofa prevents the sofa from sliding backwards during the test and also provides the reaction forces required to test the legs.

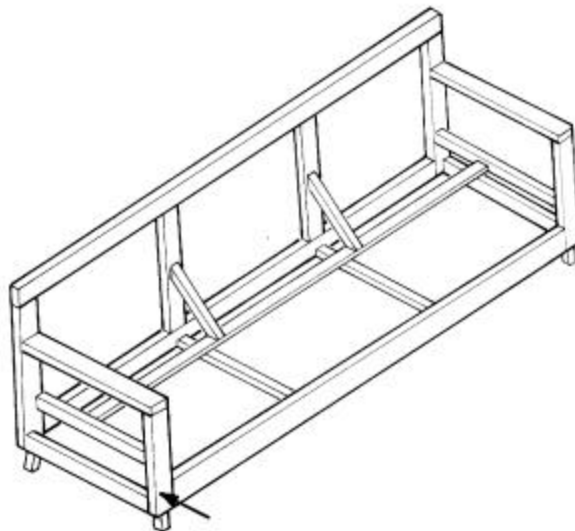

Figure 23b. Diagram showing point of application of load to the frame for the front to back load test on legs.

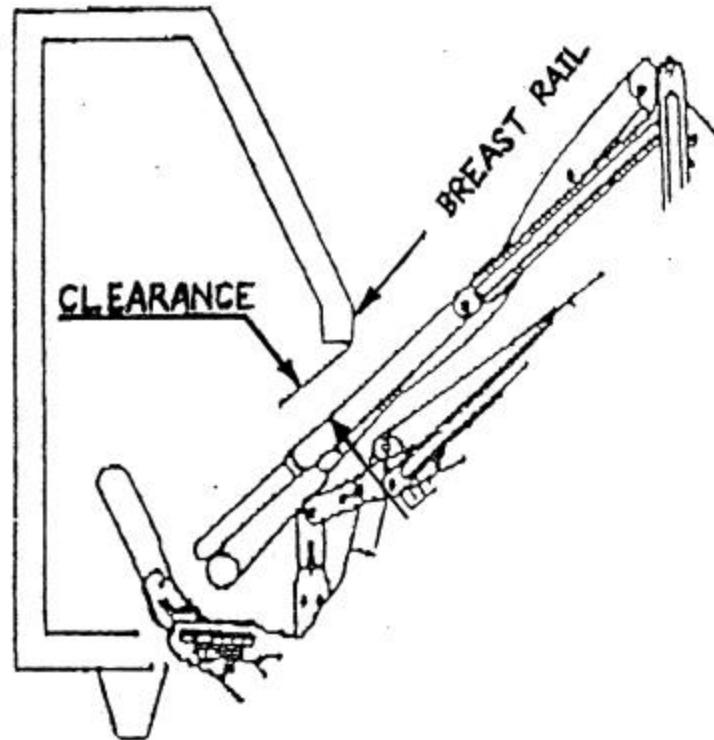

Figure 24. Diagram showing point of measurement of breast rail clearance on dual purpose unit. The measurement shall be taken at both the left and right sides. Breast rail clearance is the smallest of the two measurements.

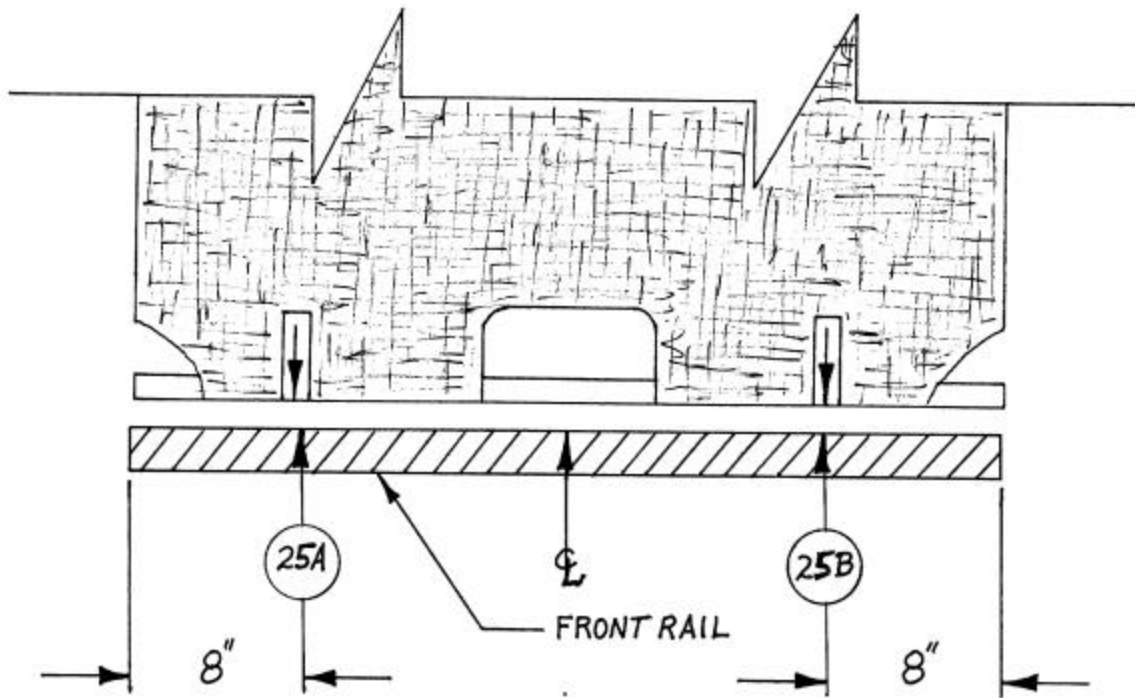

Figure 25. Diagram showing points of measurement of front rail clearance on dual purpose unit. Front rail clearance is the smallest measurement of the measurements of 25A and 25B.

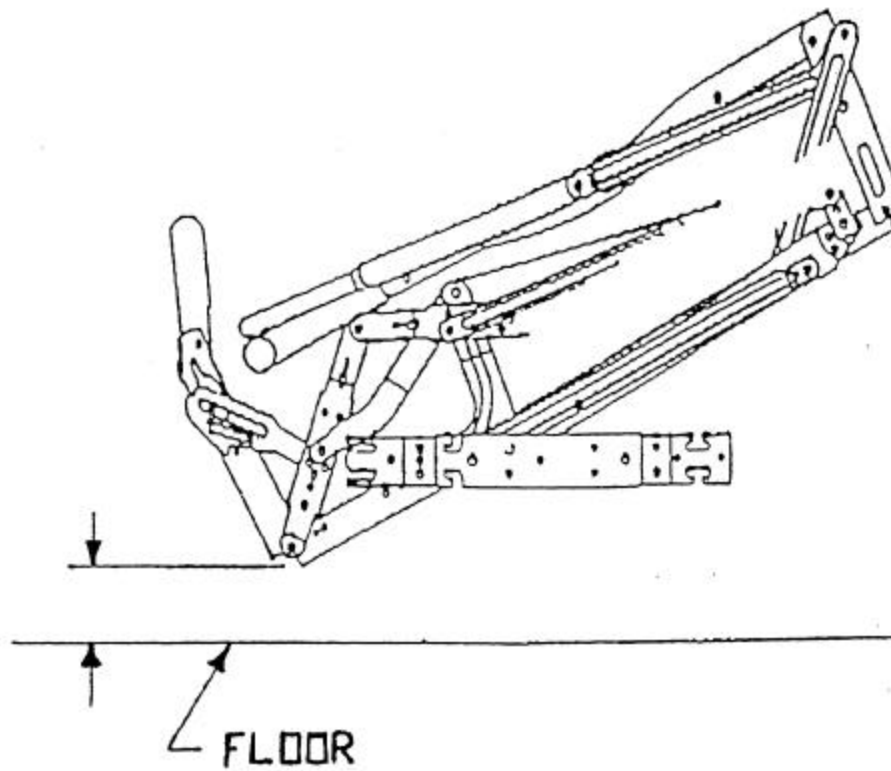

Figure 26. Diagram showing point of measurement of floor clearance on dual purpose unit in fully closed position. The measurement shall be taken at both left and right sides. Floor clearance is the smallest of the two measurements.

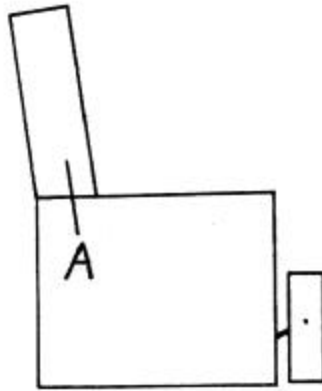

Figure 27a. Recliner in closed position.

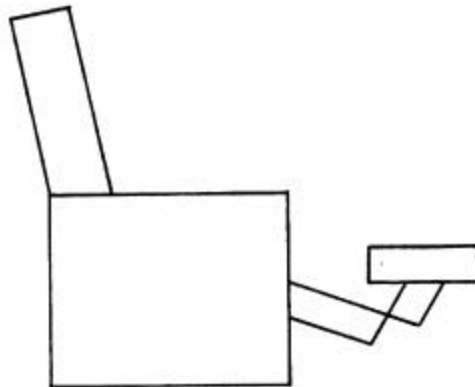

Figure 27b. Recliner in TV position.

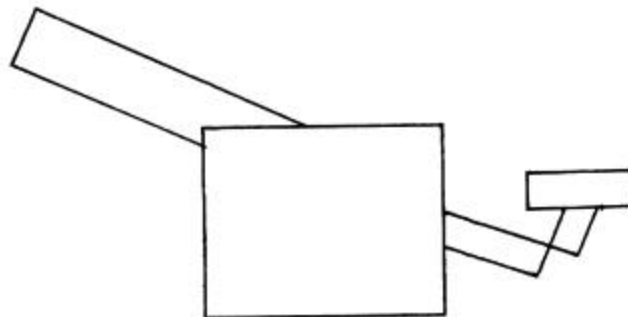

Figure 27c. Recliner in full recline position.