



National Business Space Assignment Policy

GSA Public Buildings Service Office of Portfolio
Management and Customer Engagement

August 2023 Edition



New Orleans Custom House

Table of Contents

- Document Change History5
- Preface6
- Implementation6
- History and Evolution of Spatial Data Management.....7
- Measurement Guidance9
- Developing Accurate Rent Bills10
- SDM Program Overview.....11
- Purpose12
- Drawings and Terminology14
 - SDM Assignment Drawings14
 - Terminology15
 - Diagram 1: PBS Space Assignment Diagram16
- Building Level Categories17
 - Gross Area17
 - Gross Measured Area20
 - Rentable Area.....21
 - Usable Area.....22
 - Mezzanines and Interstitial Space23
- Office Areas25
 - 01–Office25
 - Assignable Space25
 - Joint Use28
 - Shared Space.....29
 - Office Areas - Space Category and Space Class29
 - Assignable and Joint Use Space Categories.....29
 - Assignable and Joint Use Space Class.....30
- Common Area38
 - 02–Building Common39
 - 03–Floor Common40
 - Building and Floor Common Space Categories41
 - Building and Floor Common Space Classes.....41
- Vertical Penetrations43
 - 04–Vertical Penetration43
 - Vertical Penetration Space Category.....45
 - Vertical Penetration.....45

PBS Specific	47
05–PBS Specific	47
10–Unmarketable.....	47
Construction Area.....	48
Structured Parking.....	49
Unsuitable for Occupancy.....	50
17–Excluded from Gross	51
Voids.....	51
14–Zero Square Feet.....	55
PBS Specific Space Categories	56
Structures	58
Space Assignment Room Name Application and Definitions.....	59
Appendices	130
A. Space Assignment Data Matrices	131
Space Class Assignment Data Matrix	131
Space Category Assignment Data Matrix.....	132
B. Methodology Used to Measure Space	71
Dominant Portion.....	71
Space Boundaries.....	74
Unique Cases	78
Excessive Column Sizes.....	78
Alcoves and Recesses	78
C. Examples of Special Architectural Situations	80
Areaway.....	80
Atriums, Enclosed Courtyards, Lobbies, and Voids	81
Attic Space and Restricted Head Room.....	83
Balconies and Terraces.....	85
Colonnades	87
Base Isolation Systems.....	88
Façade Elements	90
Skylights and Light Wells	91
Loading Docks.....	92
Parking Ramps.....	93
Rooms with Structural Bracing.....	93
D. Glossary and Acronyms.....	94
E. Calculations	98
F. Assignment Maintenance and Building Churn.....	99
G. Assign Space by Build Out Clarification.....	100

H. Old Room Name Crosswalk with Omniclass.....	101
Addendums	116
References.....	117
Contacts	118

Document Change History

May 2009 Edition	Updated information and explanation of Rentable/Usable Ratio and Joint Use space Introduced Nonassignable Space
Feb 2013 Edition	Changed Cover Photo Updated the PBS Space Assignment Diagram, Diagram 1 Reorganized entire document to correspond to Diagram 1 Introduced Space Class - Open to Below (Void) Updated Illustrations
July 2017 Edition	Changed Cover Photo Added Document Change History table Incorporated the 3 Clarifications into the document Added Measurement Guidance section Reintroduced Unsuitable for Occupancy (UFO) concurrence and related information Added 7 new Room Names Incorporated the Land Port of Entry (LPOE) Addendum
September 2022 Edition	Changed Cover Photo. Updated all references to the current ANSI-BOMA 2017 standards. Updated Tables 2 and 3. Added more information and photos on Mezzanines Added new content on Shared Space. Updated the Building Common section Updated the Vertical Penetration section Added information on Covered Parking Added new content for Structures. Updated section on Public Waiting Areas. Added definition of Shared Space and updated definitions of UFO and Useable. Clarified wording in various parts of the document. Added Appendix F - Assignment Maintenance and Building Common Added Appendix G - Assign space by build out clarification
August 2023 Edition	Updated Space Assignment Room Name Application and Definitions Added Appendix H – Old Room Name Crosswalk with Omniclass Space Type has been renamed to Space Class Removed references to eSMART and RExUS as PBS has implemented a new system of record for billing and space called Occupancy Agreement & Space Inventory System (OASIS).

Preface

The National Business Space Assignment Policy (NBSAP) is the authoritative policy of how the General Services Administration (GSA), Public Buildings Service (PBS) assigns, classifies, and measures space in federally owned buildings. The NBSAP does not apply to leased space, except for buildings acquired as a portfolio lease. The Pricing Desk Guide defines a portfolio lease as a type of rental contract in which the leased space is priced as federally owned space using fair annual rent appraisals.

This document is a revision to the NBSAP dated July 2017. This version with its updated content and changes replaces all previous versions of this policy.

This document must be read in its entirety to fully understand GSA's principles and practices for accurately assigning and measuring space. The document also includes notes, examples, illustrations, definitions, specific examples, references, and a glossary of terms and acronyms to further assist the reader in understanding the concepts. While this document is intended for the Spatial Data Management (SDM) community of practitioners, others may find the information useful. When questions arise, please reach out to the regional SDM team for assistance and further explanation.

Exclusion from this policy as well as gaining clarifications and determinations on unique situations will be reviewed and determined by the Central Office SDM Team. When necessary, the Central Office SDM Team may include regional members and other business lines in these determinations.

Implementation

This policy is effective immediately on release for all new SDM work. Use the current policy for any internal or contracted work involving any measurement, classification and assignment of space and cite on any contracts or task orders for such work this current policy. Any buildings currently or previously measured, classified, and assigned using the NBSAP July 2017 or older versions are valid. Regions are not required to go back and re-measure each building because of this update, simply cite and use the latest version of the NBSAP next time the building has a re-measurement action.

There are cases when a policy change must be implemented across the entire inventory within a certain timeframe, such as the introduction of Voids in 2013. This revision contains no such changes.

History and Evolution of Spatial Data Management

While there are regional differences in the history and evolution of SDM, the following narrative is a broad overview of what generally took place:

Historically, hardcopy blueprints of individual tenant spaces were kept in large plan files. Plan files were typically identified by the building name with one drawer per floor. As changes to tenant spaces occurred, additional blueprints were added to the respective drawer. Square footages, necessary for the Occupancy Agreements (OA), were manually measured to scale on the actual blueprint.

The advent of Computer Aided Facilities Management (CAFM) changed this process. CAFM permitted building drawings to be created and stored electronically, eliminating the costly process of manually creating a new paper drawing every time there are changes made to any area in a building.

GSA made the decision then to employ CAFM and highly accurate electronic field measurement tools to measure the entire GSA-owned building inventory. The original hardcopy construction documents and blueprints of building changes were used as the starting point in gathering information to create the CAFM drawings. Then each building was drawn using Computer Aided Drafting (CAD) software, floor by floor, in a manner that assured the buildings remained the same size per floor and that all of the elevator shafts, stair towers, and mechanical systems stacked correctly.

Today, using space boundaries in CAD or area boundaries in BIM all the spaces in a federally owned building are drawn/modeled and classified. Each space or area boundary is associated with metadata, reflecting the assignment of the space. The building assignment metadata includes: Agency Name, Agency Bureau Code, Agency Space Assignment number (Occupancy Agreement), Space Class, Space Category, Usable Square Footage, Building ID number, Building Name, Building Address, City, State, Floor, Space Name aka SPID, Room Name, ANSI-BOMA Category and Comments.

The metadata is validated and then published to the PBS space inventory system of record, named Occupancy Agreement & Space Inventory System (OASIS). OASIS is key to GSA's accurate billing of Federal occupants.

SDM is an on-going process with three major phases:

1. Initial Measurement and Validation (IMV) – Measuring, classifying, and assigning the space within a building for the first time. Related to this, after a major remodel or modernization, we often perform something very similar, called a re-IMV or full re-measurement.
2. Maintenance – updating the drawings based on things that change frequently, sometimes daily, such as a space becoming vacant or someone moving into a previously vacant space.
3. SDM Audits and Rewalks – Periodically verifying as-built conditions and assignments. The Audit process is contracted and performed in phases while the Rewalk process is contracted as one task. These re-measurements can vary in scope depending on anticipated changes and are not as extensive as an IMV.

Although the regions' SDM programs began differently, today all are part of a national program, and the community is standardizing common processes and deliverables. Today, SDM maintains the spatial data for over 1,800 properties, which represents approximately 240 million gross square feet (GSF) nationwide.

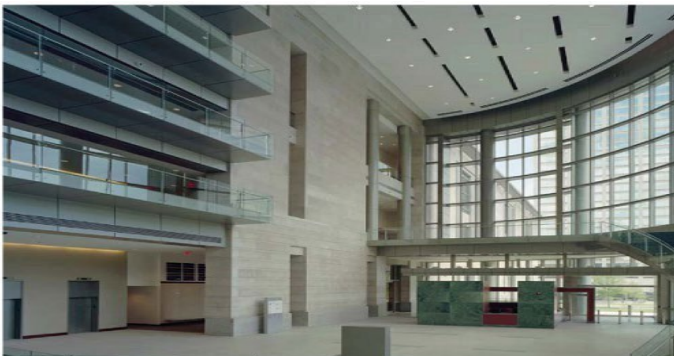

Measurement Guidance

It is our goal to conduct an IMV of every federally owned building. After an IMV, the building enters the maintenance phase and as noted above our SDM process is on-going. Here is some guidance to assist the regions on when a re-measurement action (re-IMV, SDM Audit or Re-walk) should be performed:

- After a major remodel or extensive renovation or after multiple small projects that in total changes the architecture moderately or significantly: Award or perform a re-IMV within one year of substantial completion of this significant project/remodel (pending availability of funds).

Best Practices: (1) If funding is available, complete re-IMV prior to final OA so it contains the best and most accurate SF numbers and (2) remember that for multiple projects, it is the culmination of projects that results in significant changes that triggers the re-IMV.

- For buildings with multiple small projects that in total have changed the architecture moderately or for buildings with a higher turn-over of tenants than the regional norm: An SDM Audit or Re-walk is recommended at the 10-year interval.
- For buildings with minimal small projects or improvements and where the tenants have very little turnover: An SDM Audit or Re-walk is recommended at the 10-year interval. In addition, SDM actions can be targeted or limited to one floor or one wing of the building.
- For the buildings that are not of significant value, such as kennels, or for support buildings (mechanical/electrical) that service another larger building or site: An SDM Audit or Re-walk is recommended at the 10-year interval.

The regions have discretion to use reasonable judgment to either shorten or lengthen a re-measurement interval; however, we highly recommend some type of SDM action within 10 years for most buildings. SDM initial measurement and re-measurement work can be performed via the SDM national contract, an existing regional SDM contract and in some cases with the regional SDM team. Work referenced above is subject to availability of funds. This funding can be provided by the region or Central Office.



Developing Accurate Rent Bills

While the following steps can vary, the figure below illustrates how SDM is the foundation of a process created by GSA to meet Congress' mandate that GSA charge rent to tenant agencies.

Figure 1: SDM – The Foundation for Developing Accurate Rent Bills

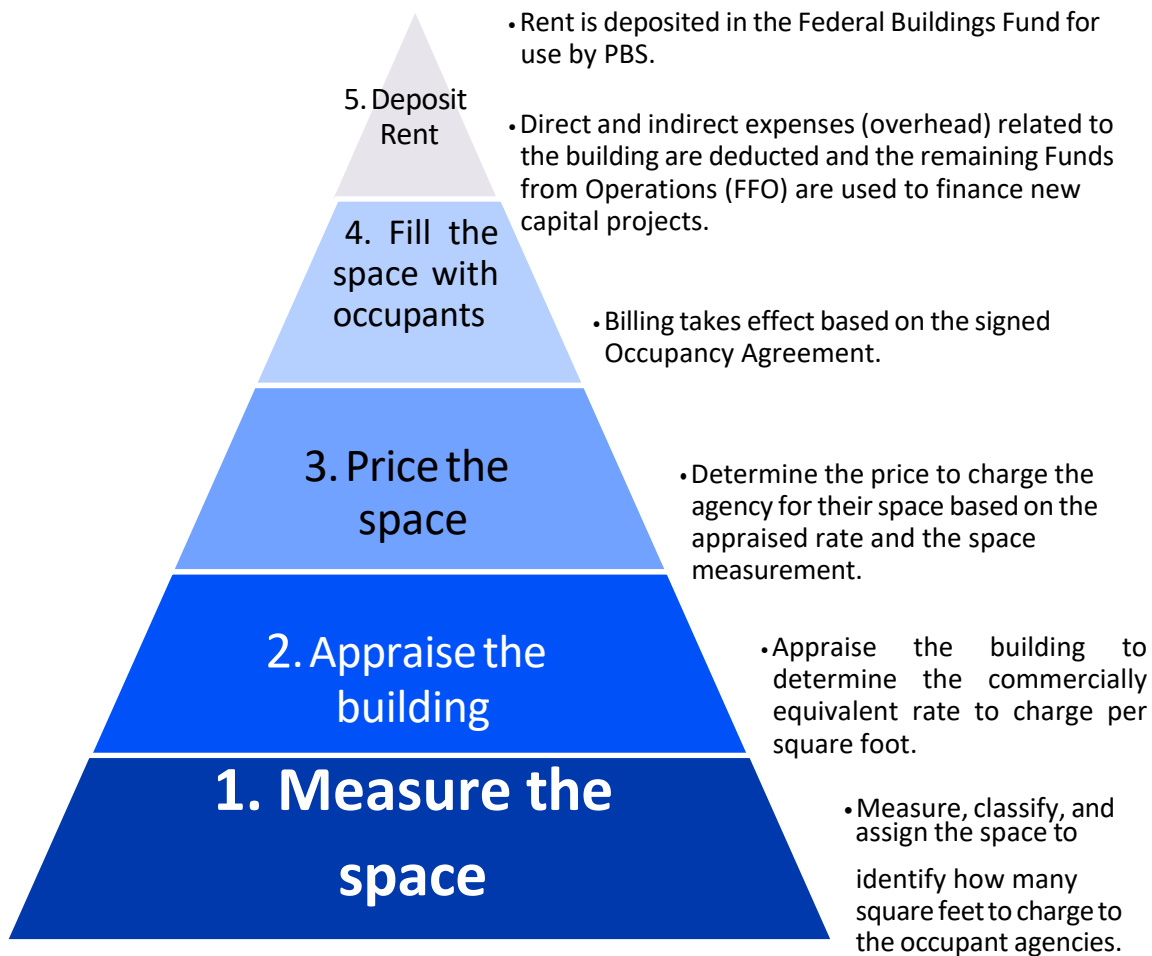

SDM Program Overview

The General Services Administration, Public Buildings Service is mandated by Congress to charge rent to occupant (tenant) agencies. To accomplish this, PBS must first measure, classify and assign the space.

The SDM Program is GSA's national effort to create, update, and maintain its spatial data and associated information. We utilize both CAD drawings and Building Information Modeling (BIM) models as the foundation to capture the architecture of the buildings and both help us accurately reflect the national federally owned inventory.

The PBS CAD Standards and the PBS BIM Guide 02 - Spatial Program Validation are used in conjunction with the NBSAP to assist the A/Es and our measurement contractors in creating drawings and BIM models used by SDM and others.

The SDM Program data also aids in the performance and use of each asset by identifying the most efficient and cost-effective way to provide workspace for federal employees.

The PBS Office of Portfolio Management and Customer Engagement, through the Central Office SDM Team, provides national program support to the regional SDM programs by:

- Issuing the National Business Space Assignment Policy (NBSAP)
- Issuing the SDM Land Port of Entry (LPOE) Space Assignment Policy Addendum
- Maintaining SDM National Business Process Flows
- Coordinating significant SDM projects
- Establishing the national SDM contract
- Providing Clarifications and Determinations

GSA has 11 regions, each of which has an SDM Regional Program Manager. The regional SDM programs manage and control their respective GSA spatial data. Asset Managers, Realty Specialists, Property Managers, tenant customer agencies and others utilize the accurate inventory and assignment information from the SDM program. The drawings produced under the National SDM Program provide a record of the PBS building inventory and can also be used as planning tools and references for building projects.

Purpose

The purpose of the NBSAP is to ensure consistent, accurate space assignment and measurement practices throughout GSA. This revision replaces all previous versions of the PBS NBSAP.

This policy document is to be used as the authoritative source for assigning space throughout PBS's federally owned and portfolio leased inventory, unless otherwise specifically requested and approved. It provides the practices, methodology, and information necessary for the correct assignment of space.

In addition, this policy provides details, examples and illustrations of how PBS measures space in both federally owned and portfolio leased inventory. Federally owned and portfolio leased buildings are measured using the standards in this policy, while leased buildings are measured using the commercial standards. See Table 1 for details.

Table 1: NBSAP Application – Federally Owned Versus Leased Buildings

Building Type	Measurement Standard
GSA Federally Owned & Portfolio Leases	NBSAP
Leased: Fully Government Occupied (entire building leased) or Partially Government Occupied (floor, room or other section leased)	Leases typically use the ANSI/BOMA standards. Many leases still refer to the 1996 version. Leasing is expected to transition to the 2017 version, Method A, in FY22 or FY23.

PBS uses the commercial American National Standards Institute (ANSI) and Building Owners and Managers Association International (BOMA) standards as a foundation for space measurement and classification. Specifically, PBS uses the following ANSI/BOMA standards:

1. **Office Buildings:** ANSI/BOMA Z65.1-2017, Standard Methods of Measurement. This standard is used as the starting point for identifying and measuring office space.
2. **Gross Areas of a Building:** ANSI/BOMA Z65.3-2018, Standard Methods of Measurement. This standard is used to identify and measure Voids.

The ANSI/BOMA commercial standards are the foundation for PBS' NBSAP. Beginning with the 1996 ANSI/BOMA standard, many of the commercial concepts and practices were adopted as well as much of the terminology. The terminology of that time was coded into our IT systems. While our policy evolves as new ANSI/BOMA standards are released, we find more differences in the terminology. So we retain terms and then use a crosswalk of terms.

We also have a very diverse inventory of properties, not just office buildings. NSBAP serves two purposes.

- (1) it captures our implementation and use of the commercial standards and
- (2) it establishes policy for situations or building types not captured in the standards or where we differ from the commercial standards, along with our GSA terminology. While going through this document, the reader will find cases where PBS's policies are very similar (or identical) to the ANSI/BOMA principles and practices.

SDM measures space in usable square feet. PBS bills agencies on the basis of rentable square feet. Space classification is based on Space Class (build-out) and not Room Names (usage).

Some notable similarities and differences between the PBS and the ANSI/BOMA standards include the following:

Similarities

- PBS' measurement and treatment of Voids is identical to the current ANSI/BOMA standards.
Note: We began with buildings that were substantially completed on or after October 1, 2013; instructions were added into the NBSAP 2013 Edition to apply to all federally- owned buildings and continues today.
- Joint Use space is Usable space that houses building amenities (e.g., childcare, fitness, shared conference centers, cafeteria, etc.). For this type of space, GSA distributes the rental costs to all building tenants based upon their prorated share of the building occupancy.

Differences

- In GSA for rent billing, there is no difference between Building Common and Floor Common. Both types of common areas are considered the same in calculating the Rentable/Usable (R/U) ratio or Load Factor.
- GSA uses term "PBS Specific" category to capture Nonassignable spaces that are measured and also to capture spaces that are not measured; referred to as Zero Square Feet items.
- Other terms and terminology. See [Table 2](#) for more information.

To the extent possible, PBS assigns space at unique facilities the same way it assigns space at other Federal Buildings. We recognize that Land Ports of Entry (LPOEs) have additional unique features; therefore, please refer to the PBS Pricing Desk Guide and the NBSAP LPOE Space Assignment Addendum for more information and guidance.

Drawings and Terminology

SDM Assignment Drawings

Assignment drawings or spatial validation BIMs are different than construction drawings/BIMs or as-built drawings/BIMs in that they contain space and area polygons to capture and track spatial data in a manner not done by other types of drawings/BIMs. SDM assignment drawings are the result of measuring, classifying, and assigning space. These drawings/models display space classifications, occupancy of space and the current square footage. The square footage is determined by using the methodology and calculations in this policy document.

GSA's PBS methods and definitions differ slightly from the ANSI/BOMA standards for the following reasons:

1. GSA uses specific terminology that is coded into various software systems (therefore, changing terms and definitions would have a significant financial impact).
2. PBS uses different building measures or considerations than commercial entities.
3. Some ANSI/BOMA terms are not used by PBS or are irrelevant to PBS.

Space in federally owned buildings is assigned using guidance found in this policy. This policy does not apply to space in leased buildings, except for space acquired as a portfolio lease. Please review the Pricing Desk Guide for the most current information on portfolio leases.

To produce the assignment drawings, the SDM measuring process begins by determining the Gross Area of the building and working down to the individual PBS Space Class. The sections that follow will provide further details on these procedures.

Terminology

First, we must illustrate the difference in terminology that will be used throughout this policy.

Table 2 below is a comparison of commonly used terms. The table lists the GSA terms and compares them to ANSI/BOMA 2017 Office Standard and ANSI/BOMA 2018 Gross Standard terms and to the ANSI/BOMA 1996 terms. ¹ This table is not all-inclusive and not all terms have direct match. For a more complete list of GSA’s terms and definitions please refer to the glossary in [Appendix D - Glossary and Acronyms](#).

Table 2: GSA Terms Compared to ANSI/BOMA Terms

GSA Term	ANSI/BOMA: 2017 Office & 2018 Gross Standard Terms	1996 ANSI/BOMA Term
Gross Area	Similar to Gross Area 4 – Construction Method	Similar to “Gross Building Area”
Gross Measured Area	Boundary Area	Gross Measured Area
Rentable Area	Rentable Area	Floor Rentable Area or Basic Rentable Area
Usable Area	Floor Usable Area	Usable Area
Common Area	Service Area	Common Area (1)
Assigned Space	Occupant Area	Office Area
Joint Use Space	Amenity Area	Common Area (2)
Vertical Penetration	Major Vertical Penetration	Major Vertical Penetration (1)
Open to Below (Void)	Building Void	Major Vertical Penetration (2)
Tenant or Occupant	Occupant	Tenant
Tenant Floor Cut, e.g. double-heighted courtrooms or private stairs	Occupant Void	Private Vertical Penetration, e.g. double-heighted courtrooms or private stairs
R/U Factor	Load Factor	R/U Ratio

The PBS Space Assignment Diagram below (Diagram 1) shows how GSA categorizes space beginning at the Building Level and working down to the individual PBS Space Class.

The Gross Measured Area includes everything except Construction Area and Open to Below (OTB). The remaining areas of the building are rentable, and they are comprised of Usable, Building Common, and Floor Common areas which follow the ANSI categories with PBS implementation of Space Class.

GSA separates ANSI Category 01–Office Area into two subcategories: Assignable and Joint Use. Assignable spaces include spaces that are assigned, committed, and vacant. Joint Use spaces include spaces that are Building Joint Use, Facility Joint Use, Lease Joint Use, and Community Joint Use.

Note: PBS uses the term “Usable Area” to include Assignable and Joint Use space.

¹ The table refers back to 1996 because PBS started its SDM program that year and based its methods on the ANSI/BOMA 1996 standards.

Diagram 1: PBS Space Assignment Diagram

This diagram shows how GSA categorizes space from the Building Level to the individual PBS Space Class, formerly known as Space Type.

BUILDING LEVEL CATEGORY		SDM ANSI CATEGORY	PBS DESCRIPTION OF SPACE	PBS SPACE CATEGORY	usage note	PBS SPACE TYPE		
Gross Area	Gross Measured Area	Rentable Area	ANSI Usable	01-Office	Assignable Space	Space Types to right can be used with any Space Category to left.	ADP Automatic Data Processing	
							AUD Auditorium	
							CFT Conference/training	
							CLD Child Care	
							CRJ Courtrooms/judiciary	
							FDS Food Service	
							FIT Fitness Center	
							GNS General Storage	
							HUT Health Unit	
							INS Light Industrial	
JCC Judicial Chambers								
JHR Judicial hearing room								
LAB Laboratory								
PTL Private Toilet								
QRR Quarters & Residence								
STC Structurally changed								
TFC Tenant Floor Cut								
TTO Office								
WRH Warehouse								
Gross Measured Area	Rentable Area	ANSI Usable	02-Building Common	Common (not considered Usable, but measured via Usable SF)	Space Types to right can be used with any Space Category to left.	CRH Circulation Horizontal		
						03-Floor Common	06-Facility Common	CST Custodial
						04-Vertical Penetration	08-Lease Common	MCH Mechanical
								TLT Toilet
SF not counted	Gross Measured Area	Rentable Area	ANSI Usable	05-PBS Specific	Nonassignable Space (not considered Usable, but measured via Usable SF)	Space Types to right can be used with Space Category to left.	CRV Circulation Vertical	
							10-Unmarketable	STP Structured Parking
SF not counted	Gross Measured Area	Rentable Area	ANSI Usable	05-PBS Specific	Nonassignable Space (not considered Usable, but measured via Usable SF)	use only with	UFO Unsuitable For Occupancy	
							17-Excluded From Gross	CON Construction
SF not counted	Gross Measured Area	Rentable Area	ANSI Usable	05-PBS Specific	n/a (not measured)	Space Types to right can be used with Space Category to left.	OTB Open To Below (Void)	
							14-Zero Square Feet	ANT Antenna
							BDK Boat Dock	
							BRG Bridge	
							KIS Kiosk	
							LND Land	
							OTH Other	
							RRC Railroad Crossing	
WYD Waregard								

Building Level Categories

Gross Area

Federally owned buildings are measured using the guidance contained in this policy. We begin by establishing the Gross Area of the building. The Gross Area is the total constructed area of a building measured to the outside of the exterior enclosing walls. Gross Area may include partially enclosed areas, but it does not include Voids.

Calculations:

Gross Area = Rentable Area + Nonassignable Space – Open to Below (Voids)

Gross Measured Area = Gross Area – Construction (CON)

Rentable Area = Usable Area + Common Area

The following enclosed areas are included in Gross Area:

- Office floors
- Atriums and lobbies only at the lowest floor level
- Basements and sub-basements
- Permanent Mezzanines
- Mechanical equipment floors
- Penthouses
- Structured parking and vehicular ramps
- Attic space
- Loading docks within the building line
- Tenant floor cut

The following partially enclosed areas are included in Gross Area:

- Parking structures (see [Structured Parking section](#))
- Loading docks within the building line
- Occupant (or multi-occupant) covered balconies.
- Covered terraces (roof terraces)
- Exterior door setbacks
- Walkways or corridors (Unenclosed Occupant Circulation)

Note: To be included in the Gross Area calculation, partially enclosed areas must have a slab or roof above and a slab or foundation below, and they must be within the building line. To be considered Unenclosed Occupant Circulation, the walkways or corridors must meet the definition described in ANSI/BOMA Z65.1-2017. When a unique situation requires a determination, it will be reviewed and determined by the Central Office SDM Team.

The following areas are excluded from Gross Area and **not measured**:

- Unenclosed areaways
- Unenclosed walkways (sidewalks)
- Unenclosed stairs
- Unenclosed spaces
- Unexcavated spaces & Unexcavated basements
- Crawl spaces
- Top floor of a parking structure if it is uncovered and unenclosed.
- Voids (where a floor might otherwise be expected or measured)

Note: On the assignment drawings, spaces excluded from Gross Area should be indicated with text to show how the space is used. When a unique situation may require an exception or ruling, it will be reviewed and determined by the Central Office SDM Team.

ANSI-BOMA no longer uses neither Construction Gross Area (CGA) nor Exterior Gross Area (EGA). Our GSA Gross Area remains consistent and is most similar to Gross Area 2 (International Comparison Method), however it differs slightly. Table 3 shows a summary of the differences between the two Gross Areas. An “X” indicates Space Class is measured and included in the Gross Area. The letter “P” means it is possible and must meet criteria; see further information in this document or the standard. Blank fields in the table below indicates the spaces are not measured and not included in Gross Area.

Table 3: Gross Area Differences between GSA NBSAP (2022) and ANSI-BOMA Z65.3-2018 Standard

GSA Gross Area	ANSI-BOMA Gross Area 2	Space Types
		Partially Enclosed Areas
X	X	Parking Structures
X	X	Loading docks within building line
X	X	Covered balconies - Occupant (or multi-Occupant)
X	X	Covered terraces (rooftop terraces)
X	P	Exterior Door Setbacks (possible in ANSI-BOMA)
P	P	Covered Walkways (* see note below)
	X	Covered arcades/galleries/shelter areas
		Unenclosed & Not Measured Areas
		Unenclosed areaways
		Unenclosed stairs (structured part of building)
		Unenclosed spaces (structured or roofed)
		Unenclosed walkways (sidewalks, connectors)
		Unexcavated spaces (unexcavated basements)
		Crawl spaces
		Top floor of Parking Structure (if uncovered/unenclosed)
		Building Voids (refer to definition in this document)

***Note:** Covered walkways may be included in both GSA’s Gross Area and BOMA’s Gross Area if they meet the definition of Unenclosed Occupant Circulation found in ANSI-BOMA Z65.1-2017.

Illustration 1: The coloring depicts the Gross Area of this floor plan. This floor layout illustrates the required elements that are included in the Gross Area.

Note: Only the lowest floor level of a multi-story space with a void, such as an atrium or lobby, is included in the Gross Area.

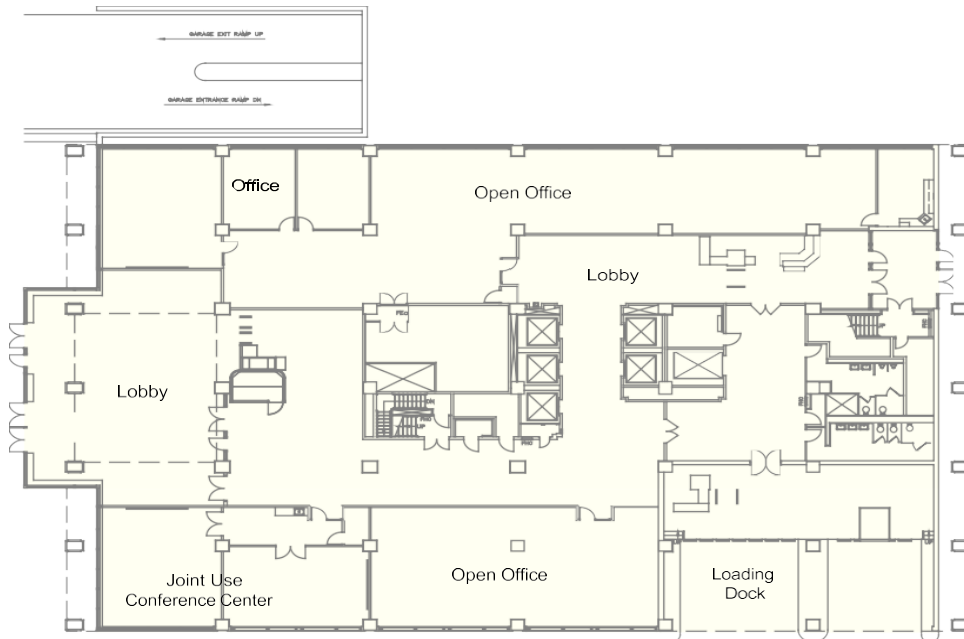
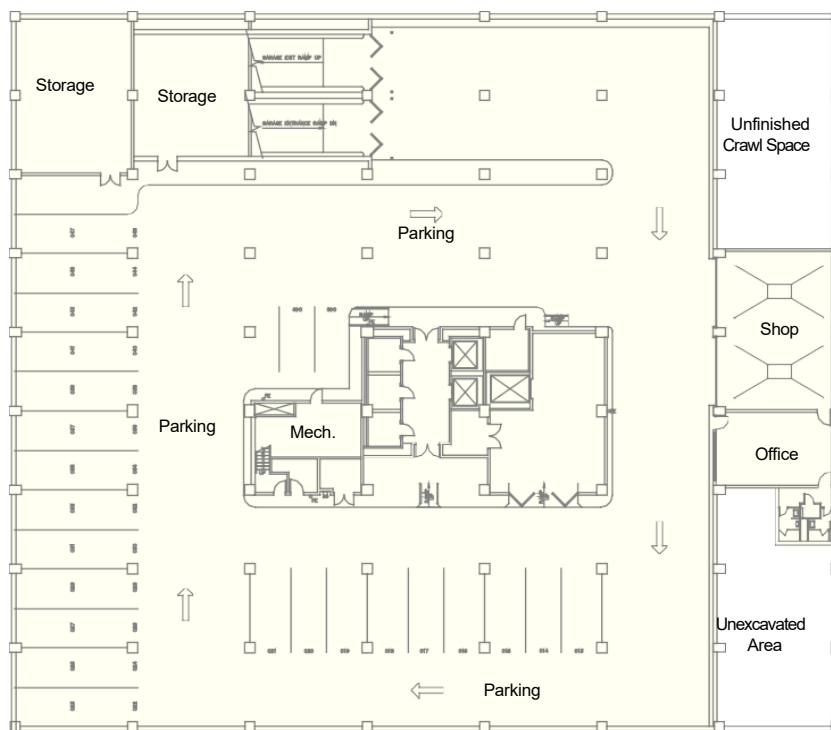

Illustration 2: The floor plan layout depicts a basement with unfinished crawl space and unexcavated space, which are excluded from the Gross Area. The coloring depicts the Gross Area of this floor plan.



Gross Measured Area

Once the Gross Area of the building has been established, the Gross Measured Area is then calculated. The Gross Measured Area is the Gross Area of the building minus the Construction Area (CON).

Calculations:

$$\begin{aligned} \text{Gross Area} &= \text{Rentable Area} + \text{Nonassignable Space} - \text{Open to Below (OTB) Voids} \\ \text{Gross Measured Area} &= \text{Gross Area} - \text{Construction Area (CON)} \end{aligned}$$

The following enclosed areas are included in Gross Measured Area:

- All Rentable Area
- Vertical Penetrations: Circulation Vertical (CRV)
- 2 cases of PBS-Specific Space
 1. Structured Parking (STP)
 2. Unsuitable for Occupancy (UFO)

Best Practice: Refer to [Appendix C – Examples of Special Architectural Situations](#) to help determine what is or is not included in the construction area.

Rentable Area

At the building level, Rentable Area is the total amount of Usable Area plus the total amount of Common Area. At a tenant level, Rentable Area is the amount of space an occupant can occupy or use within a building plus their respective share of Common Area represented by a Rentable/Usable (R/U) factor. Rentable Area is used to determine how much rent an occupant will pay. Refer to PBS' Pricing Policy for companion guidance.

Calculations:

Rentable Area = Common area + Usable area (Assignable space + Joint Use space)

Rentable Area = Usable area x Building R/U Factor

Illustration 3: The colored space depicts the building's Rentable area in this floor plan. Refer to Illustration B-3 located in [Appendix B - Methodology Used to Measure Space](#) for placement polygon along current wall.

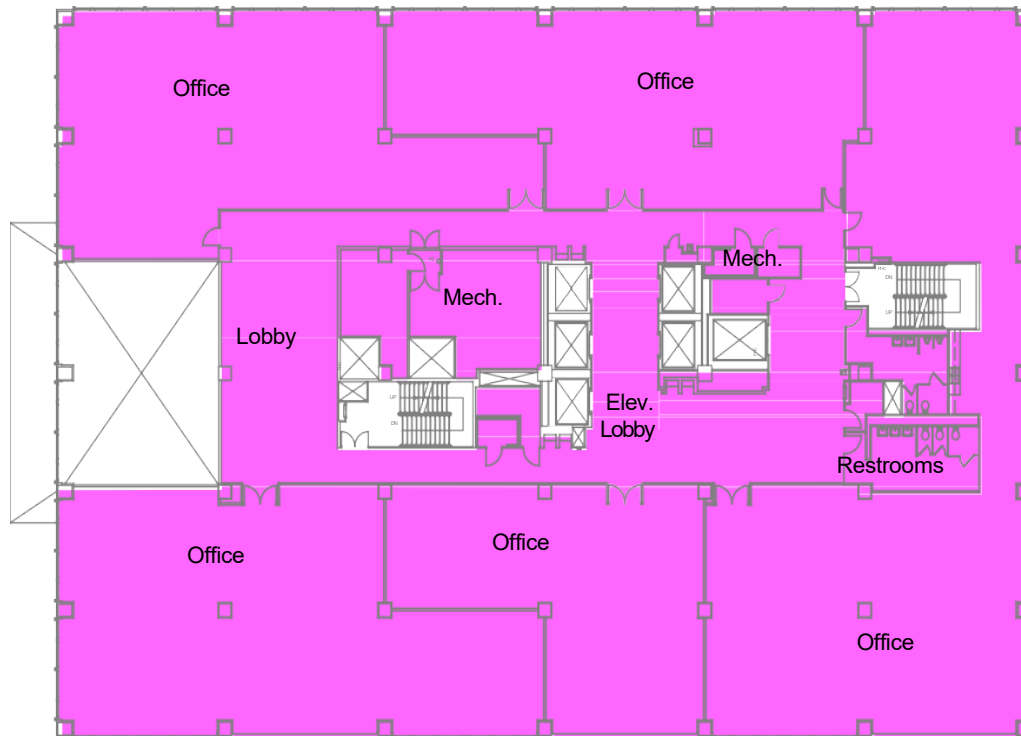

Usable Area

A subset of Rentable area is Usable area. Usable area includes space that is Assignable to a specific Occupant and Joint Use areas that can be used by all occupants.

Note:

1. PBS uses the term Usable area to include Assignable and Joint Use space.
2. Useable area includes the wall hierarchy as explained in this policy under Space Boundaries.

Calculation:

$$\text{Usable Area} = \text{Assignable space} + \text{Joint Use space}$$

Illustration 4: Colored areas depict the Usable area in this floor plan (Assignable space plus Joint Use space).

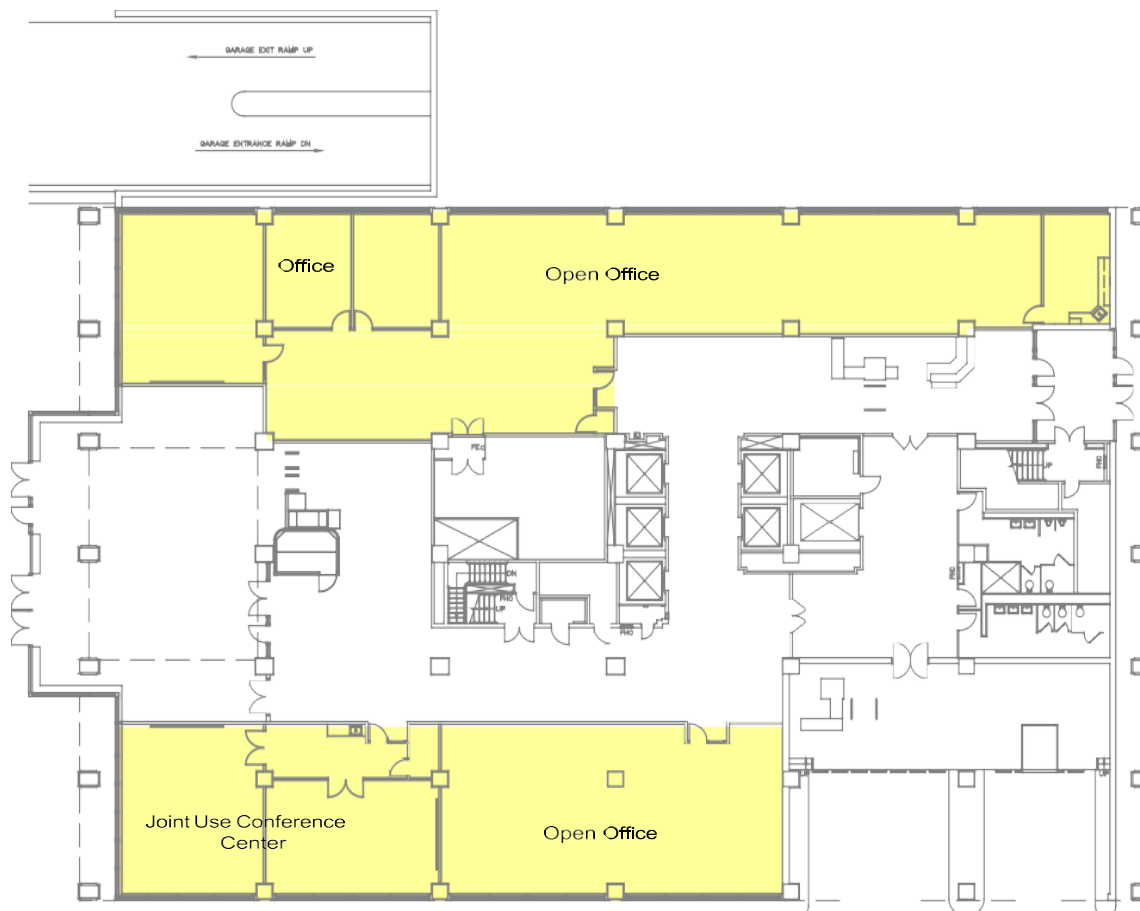

Mezzanines and Interstitial Space

A mezzanine is an intermediate floor which is partly open to the double-height floor below. Interstitial space is located between regular use floors and used to accommodate building mechanical systems and or restricted tenant circulation.

Temporary mezzanines are non-permanent. They are built with the intention of being temporary and are normally supported upon the floor below but are not part of the building's structure. GSA does not count or assign these types of mezzanines.

Photographs M1 and M2 show 2 different angles of the same structure. Notice the structure is constructed of wood, with wood walls, floor and stairs, which can easily be removed. For more illustrations, refer to the ANSI-BOMA standard.



Photographs M1 and M2
Temporary mezzanines

Permanent mezzanines are built with the intention of remaining in place for the life of the building and connected to the building's services such as lighting and power. Access is provided by the building's permanent stairs and/or elevators.

The following components of Permanent Mezzanines and Interstitial levels are included in the Gross Area calculation:

- The load-bearing floor area of the Mezzanine or Interstitial Level
- The elevators that grant access to the load-bearing floor slabs
- The mechanical Vertical Penetrations that provide service to that level
- The enclosing walls of the Mezzanine or Interstitial Level are included in the Gross.
- All other space between the Mezzanine enclosing walls and exterior building shell wall is ignored.
- Classify and assign Mezzanine and or Interstitial Level using the same guidance regarding the Office Area, Common Area or Vertical Penetrations sections as appropriate.
- Both Mezzanines and Interstitial Levels usually have below building-typical ceiling heights. When the restricted headroom is less than 7 feet it is not assignable, more than 7 feet is assignable.

Illustration 4A: Colored areas depict Gross area of Mezzanine.

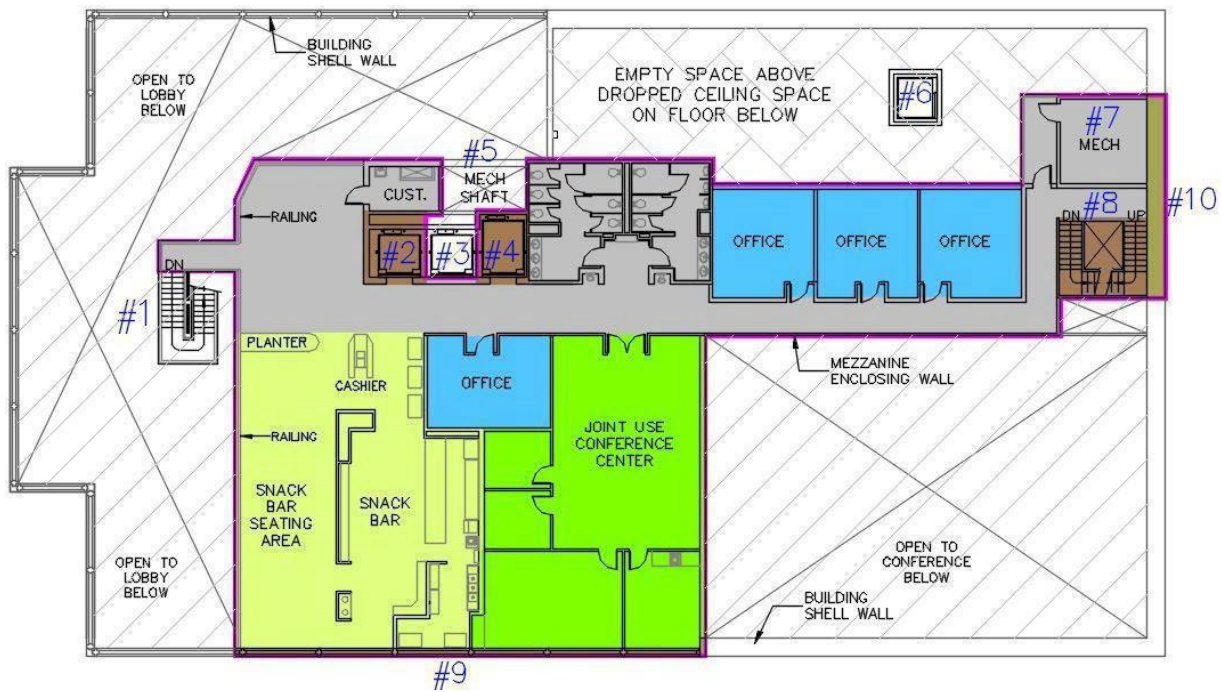

- #1 - Stair that goes only to the mezzanine is not counted on mezzanine level. It is counted once on the floor below or above.
- #2 & 4 – These elevators grant access to the mezzanine, so they are included in Gross.
- #3 & 6 - Elevators do not open onto mezzanine thus are not included in Gross.
- #5 – This mechanical shaft does not service mezzanine and is not included in Gross.

- #7 - Mechanical room supports mezzanine so is included in Gross
- #8 - Stair goes to many floors in the building; accordingly, is counted as VERT on the mezzanine level.
- #9 & #10 - Construction is included in Gross when the mezzanine’s enclosing wall is also the building shell wall. See **Illustration 4C**.

Illustration 4B: Mezzanine section

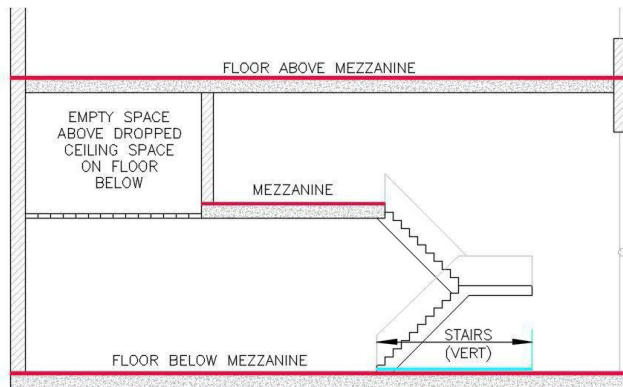

Red lines show the Floor Gross Boundary area.

Stairs that go only to the mezzanine are not counted on the mezzanine level; they are counted once on the floor below or above. In the section shown the stair vertical penetration space is counted on the FLOOR BELOW MEZZANINE because it goes to that level.

If the stairs only went up to the FLOOR ABOVE MEZZANINE the vertical penetration would be counted on that floor, and not on the mezzanine level.

Illustration 4C: Detail of mezzanine enclosing wall that is also a building shell wall.



Construction is included in the mezzanine gross only when it is part of the mezzanine enclosing wall. See # 9 & 10 in Illustration 4A.

Office Areas

SDM ANSI CATEGORY: 01–Office

PBS DESCRIPTION of SPACE: Assignable or Joint Use Space

PBS SPACE CATEGORY: 01–Assigned, 04–Committed, 11–Vacant, 03–Building Joint Use, 07–Facility Joint Use, 15–Lease Joint Use, and 16–Community Joint Use

PBS SPACE CLASS: Multiple, see Diagram 1

01–Office

The SDM ANSI Category 01–Office is equivalent to the square footage defined as Usable area. The SDM Category 01–Office includes space that is Assignable Space to a specific occupant and Joint Use Space areas that can be used by all occupants.

Calculation:

$$01\text{--Office} = \text{Assignable space} + \text{Joint Use space}$$

Assignable Space

Assignable Space is space that can be used or leased for a variety of purposes. Some specific examples of Assignable Space are:

- Space used or leased by a single occupant as a primary office.
- Space used or leased by a single occupant as primary storage space.
- Space used or leased by a single occupant as private telephone closets, uninterrupted power supply rooms, or mechanical rooms.
- Private toilets that are part of a single occupant agency’s program requirements and not part of building shell.
- Private loading docks within the building line.
- A corridor designed or used for an occupant’s use and control.
- Tenant floor cuts designed for or used by a specific occupant that are assigned and measured as though the slab exists. These spaces include courtrooms, auditoriums, stages with fly-lofts, private elevators, private stairs, dumbwaiters, and air shafts for laboratory hood exhausts.
 1. **Note:** Please refer to Illustrations 5 and 6 for examples of Occupant Voids and the Tenant Floor Cut section (Page 24) for more information on Occupant Voids.
- Property Management Office (PMO)
 1. **Note:** Assign the space class according to build out. If the space is Assignable space, use AB Code 4766. If the space is classified as support for the building to function, the space is Floor Common or Building Common.
- Maintenance and contractor space used specifically to support or service the building.
 1. **Notes:** Items to consider in assigning additional maintenance, contractor and operations space to AB Code 4762.
 1. The use of AB Code 4762 is to be used to capture spaces for building support activities, above what is provided in the base building, that currently occupy Marketable/Assignable spaces built to office standards (not INS or GNS) and not part of the original Custodial (CST) and Mechanical (MCH) spaces.
 2. Buildings are designed with a certain amount of CST and MCH spaces. Descriptions of these spaces are found in the “Common Area” section of this document. The spaces that meet these criteria are to remain assigned as such.

3. When custodial, mechanical and/or facilities management personnel expand or work exclusively in areas previously classified as built to office standards space (not INS or GNS), then these spaces will be assigned to an agency code (typically AB 4762). See "Office Areas" section for descriptions and examples of Marketable/Assignable spaces built to office standards (not INS or GNS).
 - Examples for needing additional building support space could include: the need for more office space for building support personnel, need for more storage area for tools, manuals, replacement parts and other items used to service or repair the building (multiple buildings) above what is found in CST or MCH and finally need to place new building equipment into previous office standard areas when MCH space is not available.
4. When custodial, mechanical and/or facilities management personnel expand or work exclusively in areas not built to office standards, such as INS or GNS space, then these spaces will be assigned to one of the Building Common PBS Space Categories.
 - Examples of such spaces could include spaces that are not fully conditioned, have height restrictions and spaces that have been added or modified within Mechanical or Custodial space.
5. Construction contractor staging areas or office areas that will only be used on a temporary basis (i.e., the length of remodel or construction project) will remain assigned what they were before the project (for example if Vacant, then leave as Vacant). If there is a permanent designated staging area used for a variety of projects or personnel and the space meets office standard definition, assign to an agency code (AB Code 4762 if managed and controlled by GSA). While regions have some discretion on use of AB Code 4762 in semi-permanent staging areas, the use of this code was not meant to change frequently.

Illustration 5: TFC / Occupant Void Over Courtroom

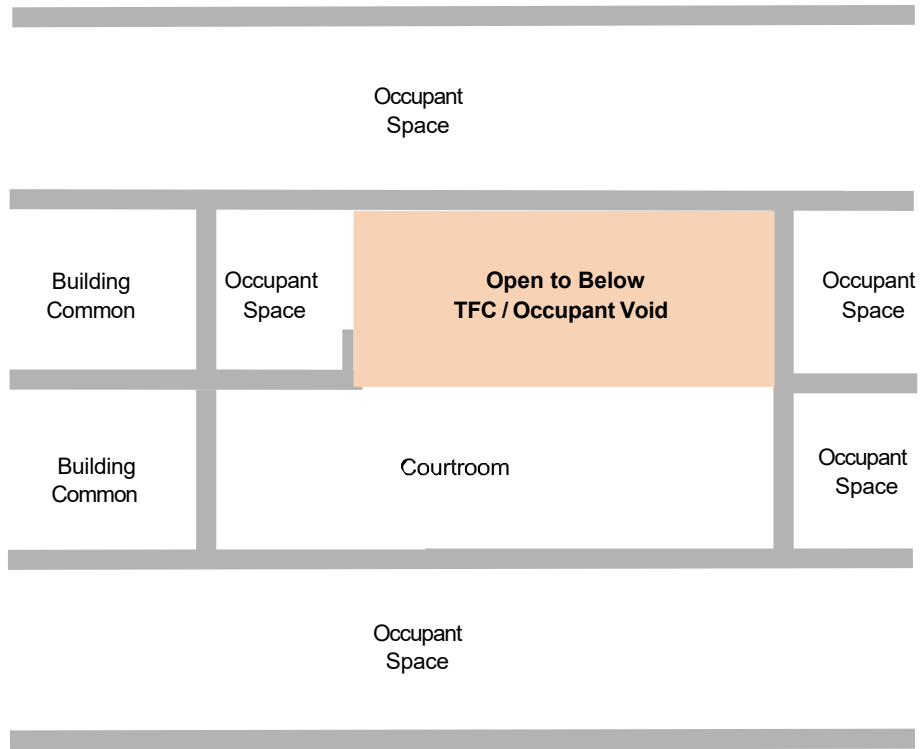
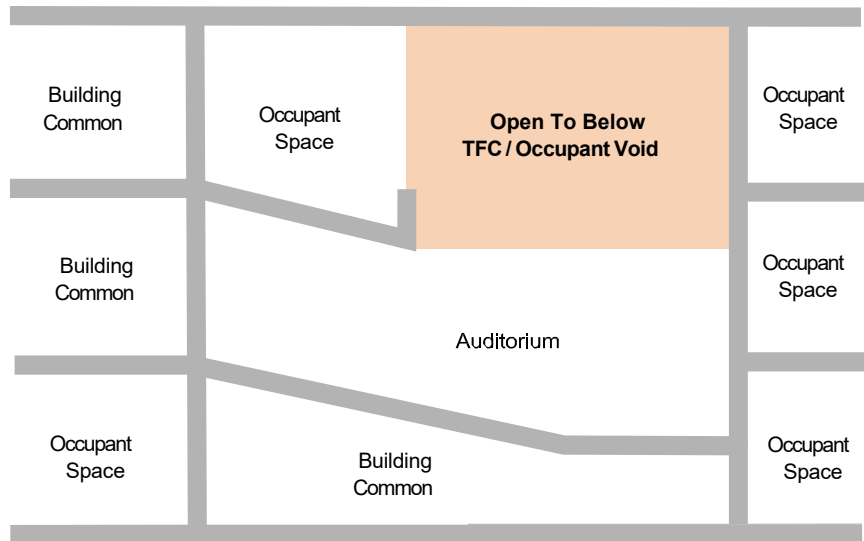

Illustration 6: TFC / Occupant Void Over Auditorium



Joint Use

Joint Use spaces are amenities available for use by all occupants of a building, community, facility, or lease. An amenity designed for, used by, or converted for use for a single occupant is considered an occupant-only amenity and is an occupant assignment and not Joint Use. There are exceptions to this rule: childcare centers, cafeterias, and vending stands operated under the Randolph-Sheppard Act in non-delegated owned buildings are assigned as Joint Use. If there are multiple occupant agencies (multiple agency bureau codes), the amenities are assigned as Joint Use.

Note: GSA's occupancy within a building or facility does not constitute an agency that would impact the assignment of an amenity to a single occupant.

There are four types of Joint Use:

1. **Building Joint Use:** Includes amenities that are housed in the building and are available only to the occupant agencies in the building. In the case of leased buildings with multiple leases, if the amenities are available to all the Federal occupants in the building, the space is assigned as Building Joint Use.
2. **Community Joint Use:** Includes amenities such as childcare centers or cafeterias housed in one building that are available to occupant agencies in neighboring buildings.
3. **Facility Joint Use:** Includes amenities that are shared among two or more buildings that are designated as a facility within the inventory system.
4. **Lease Joint Use:** Includes amenities housed in the lease that are available only to the occupant agencies in the lease. In the case of leased buildings with multiple leases, if the amenities area is available to only the Federal occupants in one lease, the space is typically assigned as Lease Joint Use.

Typical examples of Joint Use space include the following:

- Library
- Cafeteria
- Vending
- Fitness center
- Conference room/center
- Credit union
- Childcare
- Health unit
- Building Mail Room
- Leadership in Energy and Environmental Design (LEED) related spaces, such as Bike rack rooms and certain showers, etc.
- Wellness rooms
- Lactation rooms are assigned Joint use if accessible by all the tenants in the building.

Shared Space

Shared space is space that is shared among only a small group of tenants. It is not a building amenity open to all tenants.

GSA PBS will accommodate creating, splitting and showing such shared spaces on our drawings and capturing them on our OAs under the following conditions:

1. There is a written agreement among sharing agencies that if one agency moves out, GSA will re-apportion the space among the remaining agencies.
2. The request must be reasonable; GSA reserves the right to deny certain requests which would become too maintenance intensive to GSA (i.e., splitting spaces among too many AB Codes). In addition, the agencies accept that odd, shaped spaces, GSA SDM can use a percentage to allocate space.
3. The overall GSA regional team will make the final decision.

Office Areas - Space Category and Space Class

All space assignments will have a Space Category and a Space Class.

Space Categories are used within the PBS inventory system to identify a room's status of occupancy. The two-digit Space Category numbers are recognized by the PBS inventory system.

Space Class is used within the PBS inventory system to identify a room's build-out. The three-letter Space Class acronyms are recognized within the PBS inventory system.

Note: Data matrices for the application of Space Categories and Space Class can be found in [Appendix A - Space Assignment Data Matrices](#).

Assignable and Joint Use Space Categories

01–Assigned

Identifies Usable space within a building that is assigned to a specific client agency.

03–Building Joint Use

Amenities housed in the building that are available to only the occupant agencies in the building.

04–Committed

A Usable space or amenity identified for future use by a specific client agency.

07–Facility Joint Use

Amenities shared among two or more buildings designated as a facility within the inventory system.

11–Vacant

Unassigned Usable space.

15–Leased Joint Use

Amenities shared by all building occupants in the lease.

16–Community Joint Use

Amenities such as childcare centers or cafeterias housed in one building and shared by occupant agencies in neighboring buildings.

Assignable and Joint Use Space Class

ADP–Automatic Data Processing

Space that typically contains ADP equipment with the following features:

- Local area networking (LAN) cabling distribution
- Electrical upgrades
- Above-standard heating, ventilating, and air conditioning

(HVAC) **Note:** Normally includes a raised floor, but not all raised floors are

ADP space. **AUD–Auditorium**

Space that typically contains the following features:

- Stages
- Stadium seating
- Sloping floors
- Ceilings exceeding 10 feet (typically with tenant floor cuts or Voids) (see Illustration 6)
- Audiovisual equipment, increased floor loading, above-standard lighting and HVAC, and is larger than 400 square feet.

CFT–Conference/Training

Space that contains several of the following features:

- Special audiovisual equipment
- Soundproofing
- Chair rails
- Paneling
- Marker boards
- Blackout curtains, supplemental lighting, and HVAC. Spaces can include conference rooms, training rooms, hearing rooms, and libraries.

Note: These spaces do not meet Judicial Hearing Room (JHR) requirements. CFT refers to the build out of the space, not the use of the space.

CLD–Child Care

Space that is specifically built for childcare use and contains features such as:

- Above-standard flooring
- Indoor play area
- Above-standard toilet rooms
- Laundry facilities

Note: Spaces inside a childcare unit are classified by the build out of the space. All childcare space has a room name of Child Care for querying purposes.

CRJ–Courtroom/Judiciary

Space with features such as:

- Ceilings that exceed 10 feet (typically with tenant floor cuts)
- Courtroom entry vestibule with or without sound lock
- Column spacing that exceeds 30 feet on center
- Above-standard lighting and HVAC
- Extensive millwork and cabinetry, or unique ceiling ornamentation/plane changes.

Notes:

- (a) Spaces can include courtrooms for the U.S. District Court, U.S. Tax Court, U.S. Court of Federal Claims, U.S. Magistrate Judges, U.S. Court of Appeals, and U.S. Bankruptcy Court.
- (b) Use of the space may not always be by judicial agencies. Classification is based on build out.

FDS–Food Service

Space dedicated to preparing, dispensing, and/or consuming food. Spaces include:

- Cafeterias
- Seating space in cafeterias
- Snack bars
- Vending machine areas
- Private kitchens with plumbing
- Break rooms with plumbing

Note: A food service area (if it is part of a larger room) is to be measured at 5 feet from the face of the counter or vending machine area.

FIT–Fitness Center

Space with features such as increased floor loading, above-standard flooring, above-standard lighting and HVAC, ceiling fans, mirrors, and grab bars.

GNS—General Storage

Space that is used for storage and has significant diminished use that prohibits the space from otherwise being used as standard office space, typically found in basements or attics and it meets the following characteristics:

- Space must have permanent conditions, obstructions, or protrusions below the ceiling height and into or within all or a portion of the space that do not allow for general office use and it would be cost prohibitive to build out the space to office standards, and
- Space is typically not within standard office space and the space is not completely built out to shell.

Space that is used by an occupant as storage and is built out to office standards is assigned a Space Class of Total Office (TTO). Storage space that is not built out to office standards may be assigned as either Space Class GNS or INS, according to the build out.

Note: Refer to PBS’ Pricing Policy for additional information. Consult with your regional SDM RPM on assignments. In cases where there is still ambiguity, contact the Central Office (SDM Team), who will consult with Pricing and make the final GNS classification decision.

Table GNS-1: This table compares features to assist in determining whether space is GNS versus INS. For a space to be classified as GNS it must meet both the “Protrusions and Obstructions” and “Ability to Convert to Office Standards” criteria in addition to at least one other feature criteria. For more information on building shell refer to the Pricing Desk Guide.

Feature	GNS	INS
A GNS classification must meet <u>both</u> the “Protrusions & Obstructions” and the “Ability to Convert to Office Standards (TTO)” criteria.		
Protrusions & Obstructions	Can emanate from walls, floor or ceiling, they are permanent, and they render space unable to meet Office standards	None or very minimum
Ability to convert to Office standards (TTO)	Cost prohibitive	Not cost prohibitive
And at least <u>one</u> of the following features.		
Location	Space is typically not within standard office space	Space could be anywhere
Lighting & HVAC	Does not meet shell	Less than full Office features
Floor	Unfinished floors	Concrete, typically unfinished
Ceilings	Open or unfinished. Could not meet 7-ft minimum height requirement if they were to be finished	Open or unfinished. If finished, needs to meet 7-ft minimum height requirement

Note: There are some rare instances where a space can have no Protrusions and Obstructions and still be considered GNS space. These spaces will have permanent diminished conditions that are cost prohibitive to correct or convert. In these situations, they must meet the location criteria and have 2 of the additional features on table.

Photograph GNS-1: This photograph shows a typical example of GNS space; located in the basement, contains obstructions and protrusions and it would be cost-prohibitive to convert to office standards.



HUT–Health Unit

Space built to accommodate medical equipment with plumbing. Spaces can include:

- Exam rooms
- Waiting rooms
- Wellness rooms
- Laundry facilities

INS–Light Industrial

Space that is intended for or can be converted to office use, but it is not built to office standards. Light Industrial space may also be built out to provide a specific use for an occupant, and has the following characteristics:

- Less than full features for HVAC and lighting
- Unfinished concrete walls and/or floors
- Open or unfinished ceilings
- Not cost prohibitive to build out the space to office standards

Types of Light Industrial spaces that are within the building line include private loading docks, private elevator mechanical rooms (built to the specific needs of an occupant), and storage rooms.

The INS Space Class is not used for spaces that are built out as general office space.

Note: Light Industrial (INS) differs from Warehouse space (WRH).

- Warehouse space has large column spacing (30 feet on center or greater), typically includes large open areas such as bays, and is not easily converted to office space.
- Light Industrial space typically refers to rooms within office space (TTO).

Photograph INS-1: This photograph shows a typical example of INS space; note space has lighting, HVAC, walls, etc. It would not be cost prohibitive to build out the space to office standards. Space contains no significant protrusions or obstructions.



JCC–Judicial Chambers

Space with features exceeding typical office space standards such as extensive wood millwork, wood base, chair rail, fabric wall covering, vinyl wall covering, sound board, speakers, closed-caption television (CCTV) monitors and/or cameras, panic buttons, recessed can lighting, ceiling fans, and cabinetry. Spaces can include chambers for Court of Appeals, District, Magistrate, Bankruptcy, Claims, and Tax judges. Space can include above-standard lighting, security systems, and/or HVAC. Classify spaces to build out. Included in the chamber's spaces are:

- Judge's private office
- Robing room
- Conference room
- Corridors
- Reception
- Closets
- Private toilet
- Judges' libraries
- Law clerk offices (when part of the judges' chambers)
- Service unit (break area)
- Secretarial area

JHR–Judicial Hearing Room

Small court facilities that can include court facilities for Senior District Judges, Bankruptcy Judges, and Magistrate Court Judges. JHR is used for small courtrooms. Spaces typically have these features:

- Column spacing less than 30 feet on center
- Above-standard lighting such as recessed can lighting
- Above-standard HVAC such as separate air
- Built-in items, such as judge's bench, chair rail, sound system, podium, spectator railing
- Wall-to-deck crown molding, articulation in the ceiling
- Above-standard doors, sound lock entry
- Millwork and cabinetry, although smaller in scale than found in CRJ

LAB–Laboratory

Space that has built-in equipment, plumbing, and/or utilities for experimentation, the qualitative and/or quantitative analysis of matter, the processing of materials, and photographic development, including wet, clean, and photographic laboratories.

A laboratory may have the following characteristics:

- Corrosion-resistant/stainless steel countertops
- Gas supply plumbing in the wall or the floor
- Special venting equipment
- Quarry tile flooring
- Floor drains
- Light lock doors for photo labs
- Above-standard electrical for testing equipment
- Special lighting
- Separate climate control systems

PTL–Private Toilet

Restrooms or shower/locker rooms built for the private use of an occupant as part of their program of requirements.

Note: A private toilet is not provided as part of building shell. It is provided as a result of occupant requirements.

QRR–Quarters/Residence

Space built for residential quarters in Government-controlled spaces.

Note: Spaces can include military barracks or remote land ports of

entry. **STC–Structurally Changed**

Space with features such as increased floor loading, above-standard wall construction, concrete or wire-mesh walls, and ballistic glass. Spaces can include:

- Vaults
- Holding cells
- Evidence rooms
- Secure sally ports within the exterior building line
- Target ranges

TFC–Tenant Floor Cut

An opening in a floor above an occupant's finished floor: (a) designed for or (b) exclusively used by or (c) controlled by a specific occupant, such as a multi-level courtroom. The floor cut eliminates otherwise Usable space. BOMA defines a tenant floor cut as an Occupant Void. This space may be part of the original building design or renovated by removing a portion of the slab or not installing a slab where could be expected. Spaces can include:

- Private elevators
- Dumbwaiters
- Private stairs
- Private air shafts
- Multi-level courtrooms
- Multi-level auditoriums

Notes:

- (a) If the upper portion of an occupant's multi-level space, such as a courtroom, penetrates mechanical space, a roof or unmarketable attic space, it must be tagged as a 05–PBS Specific, designated 17–Excluded from Gross, and given the Space Class OTB (Open to Below). See Illustration 16 (below) for example.
- (b) If there is occupant space: (a) adjacent to or (b) on the same floor as the upper level of the multi-level space on a floor, the space must remain TFC, despite the presence of mechanical space. Consider if TTO space could have been built where the TFC exists, would it have access to a corridor, etc.

TTO–Total Office

An environment for office operation with features such as HVAC and lighting, finished floors, ceilings, and walls. Types of total office spaces include:

- An office or open office space housing personnel and furniture
- Closets within the general office space
- Private corridors
- Meeting and training rooms that do not meet criteria for conference/training (CFT)
- Storage in office space
- Reception space
- Health rooms without equipment
- File space without increased floor load
- Pedestrian processing space at land ports of entry
- Property Management Office (PMO)
- Maintenance and contractor space used specifically to support or service the building.

Note: Assign the Space Class according to build out. Use Room Name to capture how space is being used.

WRH–Warehouse

Space built for materials storage and handling operations with features such as concrete floors, unfinished ceilings, industrial lighting, overhead doors, minimal HVAC, and large column spacing (30 feet on center or greater). This space typically includes large open areas such as bays, higher than normal ceiling heights, special floor load capacities, and it is not easily converted to office space.

Note: Warehouse space is generally not located in office buildings; however, both Space Class (WRH and TTO) may exist in the same building. WRH refers to a Space Class and not building class; refer to the PBS Pricing Policy for additional information on Predominant Use.

Common Area

SDM ANSI CATEGORY: 02–Building Common and 03–Floor Common

PBS DESCRIPTION of SPACE: Common

PBS SPACE CATEGORY: 02–Building Common, 06–Facility Common, and 08-Lease Common

Common area is defined as the area of the building that provides services, support, and horizontal circulation to building occupants. Assignable space is not included in the calculation of Common area. Building services, support, or circulation for a specific occupant are assigned to that occupant.

There are two types of Common areas: Floor Common and Building Common. Floor Common areas are spaces that pertain to a specific floor of a building, such as corridors. Building Common areas pertain to all floors of a building, such as elevator lobbies. PBS measures Building Common and Floor Common areas using the same guidelines as ANSI/BOMA. However, unlike ANSI/BOMA, PBS combines the two areas to determine the building's R/U Factor. The building's R/U Factor is used in calculating an occupant's prorated share of Common area.

The sum of all Common area (Floor + Building) within a building is included in the Rentable Area calculation. The R/U Factor is Rentable Area divided by Usable Area, which determines the Rentable to Usable ratio.

Calculation:

$$R/U \text{ Factor} = \text{Rentable Area} \div \text{Usable Area}$$

Illustration 7: Colored space depicts Common area of a floor plan.

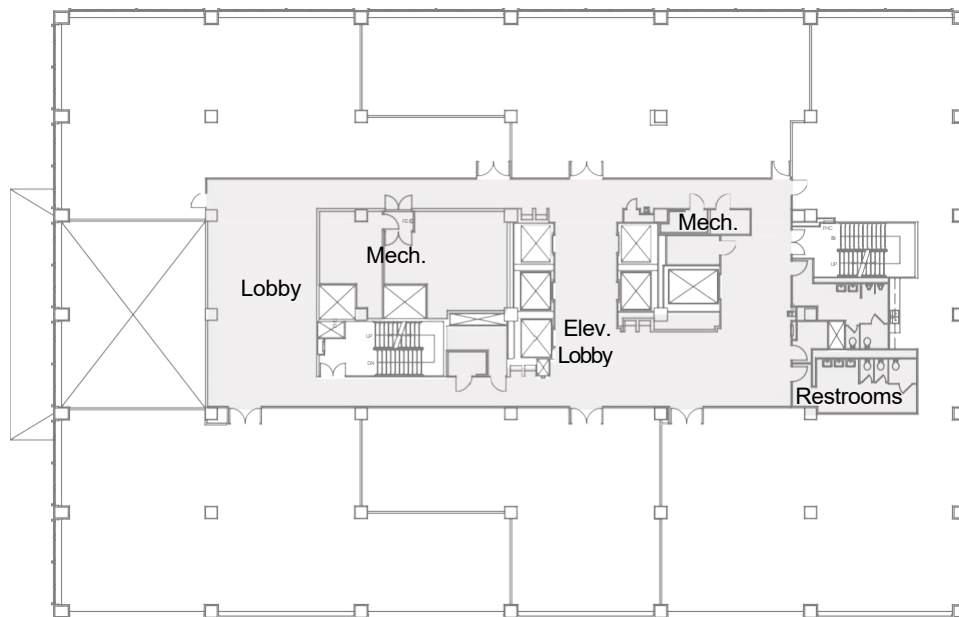

02–Building Common

Building Common areas provide services or circulation to all building occupants. Parking, vertical penetrations, and portions of loading docks that are outside the building line are not included in the definition of Building Common area. Examples of Building Common areas are:

- Atrium spaces at the finished floor level.
- Main and auxiliary lobbies that are used by all occupants in the building and that lead to the main entry-level elevator lobby.
- Mechanical service areas that support multiple floors.
- Mechanical service areas that support the entire building.
- Occupant support or security areas such as concierge, Kiosks, security desks, checkpoints, and fire suppression control rooms that support the entire building.
- Support areas such as custodial storage; custodial shop areas; janitorial closets; and electrical, telephone, mechanical, and equipment rooms that support multiple floors in the building; and storage for recyclables or dumpsters that serve the building.
- Additional examples include mechanical shops that service the building or multiple buildings, locker rooms and break rooms located within CST and MCH areas that are designated exclusively for use by the custodial and mechanical staffs.
- Fully enclosed courtyards at the finished floor level.
- Toilets and their associated vestibule and plumbing chases provided as part of the building shell.
- Spaces used for the sole purpose of supporting or servicing building operations.
- Guard and building monitoring stations that support the entire building, can include (U.S. Marshals Service (USMS), Federal Protective Service (FPS) and Contract Security.
 1. **Note:** Please contact your regional SDM Program Manager for issues related to assignment of guard and building monitoring stations or consult the PBS Pricing Desk Guide and the 2018 DHS/GSA Memorandum of Agreement (MOA) or latest version. This is typically assigned as Space Class CRH.
 2. FPS and GSA's Office of Mission Assurance (OMA) security equipment rooms – FPS handles exterior security and OMA also has equipment rooms usually on first floor that service the entire building; assign these spaces as Building Common. If there is a separate, monitoring or equipment room that provides redundant or extra security for an agency, these rooms are assigned to that agency.
 3. Security closets if used and controlled by an agency, they are assigned to that agency.

Note: In Courthouses this is typically a program area in the USMS requirements. We assign to USMS as it houses security equipment for Courts and USMS. Examples are security risers, typically one per floor, sometimes more.

- Telecom/IT closets spaces fall into 2 categories:
 1. spaces are agency assigned (whether located in the building core or another part of the building) if the space is controlled by the agency and
 2. spaces are Building Common (whether located in the building core or another part of the building) if multiple agencies have equipment in the space and all agencies who have equipment in the space have access to the space.
- Property Management Office (PMO)

Note: Assign the Space Class according to build out. If the space is Assignable space, use AB Code 4766. If the space is classified as support for the building to function, the space is Floor Common or Building Common.

- Maintenance and Contractor space used specifically to support or service the building.
Note: Assign the Space Class according to build out. If the office supports a single building and space cannot be used for or easily converted to Usable Space, the office should be assigned as Floor Common or Building Common. If the space supports a single building and is built to office standard, assign space to GSA using AB Code 4762. If space supports multiple buildings, the office is assigned to GSA (4762). For delegated buildings, space is assigned to the occupant agency with which GSA has the delegation agreement.
- Federal Executive Board (FEB) space – refer to OAS Order 4240.2 (or most current) for latest assignment information.

03–Floor Common

Floor Common areas provide services or circulation to occupants on that floor. ANSI Category 03–Floor Common includes PBS Building Common and Lease Common. Typical examples of Floor Common are:

- Public corridors
- Elevator lobbies
- Support areas such as custodial storage; janitorial closets; and electrical, telephone, mechanical and equipment rooms; and storage for recyclables or dumpsters that serve a floor
- Toilets and their associated vestibule and plumbing chases provided as part of the building shell

PBS measures Building Common and Floor Common using the same guidelines as ANSI/BOMA. However, unlike ANSI/BOMA, PBS combines the two to determine the building’s R/U Factor. The R/U Factor is used in calculating an occupant’s prorated share of Common area.

Common Areas - Space Category and Space Class

All space assignments will have a Space Category and a Space Class.

Space Categories are used within the PBS inventory system to identify a room’s status of occupancy. The two-digit Space Category numbers are the entries recognized by the PBS Inventory system.

Space Class is used within the PBS inventory system to identify a room’s build-out. The three-letter Space Class acronyms are the entries recognized within the PBS inventory system.

Note: Data matrices for the application of Space Categories and Space Class can be found in [Appendix A - Space Assignment Data Matrices](#).

Building and Floor Common Space Categories

02–Building Common

Square footage within a building for service and circulation to support that building and is prorated among all occupants in a building. This includes Circulation Horizontal, Custodial, Mechanical, and Toilets.

06–Facility Common

Square footage within a building, in a facility for service and circulation space to support that facility and is prorated among all occupants in the facility. This includes Circulation Horizontal, Custodial, Mechanical, and Toilets.

08–Lease Common

Square footage within a lease in a building for service and circulation space to support that lease and is prorated among all occupants in the lease. This includes Circulation Horizontal, Custodial, Mechanical, and Toilets.

Building and Floor Common Space Class

CRH–Circulation Horizontal

This is common space attributable to a building or particular floor. Types of circulation horizontal spaces include:

- Elevator lobbies
- Public lobbies
- Entrance lobbies
- Public corridors
- Public loading dock portions that are within the building line
- Guard and building monitoring stations

Corridor's housing personnel and furniture, private corridors, and private loading docks designed for or used by one occupant are not classified as Space Class CRH. These spaces are assigned to that particular occupant as Usable space.

Note:

Factors such as “designed for” and/or “control of” a corridor determine whether it is assigned to the tenant, or it is building common. Each situation is assessed individually. Contact your regional SDM team for more information.

CST–Custodial

Space needed for general operation and maintenance of a specific building. Types of custodial spaces include:

- Custodial closets that house custodial sinks and/or floor drains
- Custodial storage of doors, ceiling tiles, light bulbs, paint, and supplies
- Storage for recyclables and/or dumpsters that serve the building

MCH–Mechanical

Space providing service to the building or housing mechanical equipment, which can include but is not limited to:

- Boiler rooms
- Mechanical and electrical rooms
- Enclosed cooling towers
- Fuel rooms
- Elevator machine rooms
- Wire closets
- Telephone frame rooms
- Transformer vaults
- Incinerator rooms
- Motor closets
- Building automation/monitoring rooms
- Fire control rooms or fire command center
- Horizontal air plenums

A mechanical room platform (typically metal-mesh floor) that is constructed for the sole purpose of gaining access to mechanical equipment should not be counted as part of the total mechanical space (there may be numerous mechanical room platforms within one mechanical room). These areas are typically accessed by ladder or stairs.

Note:

1. Mechanical rooms built to the specific needs of an occupant are assigned to the occupant as INS space, not MCH.
2. See CRV section for assignment of upper portions of MCH space.

TLT–Toilets

Toilets that are provided as part of building shell on a specific floor or lobby area.

Note: Toilets provided as part of the building shell behind an occupant-restricted corridor will still be assigned as TLT unless they are part of the occupant requirements under occupant improvements.

Best Practice: One way to determine if they should remain assigned TLT is if the space is unchanged. If modifications are done due to tenant requirements, such as converting toilet stalls into showers, etc., then they become assigned to the tenant as Private Toilet (PTL).

Vertical Penetrations

SDM ANSI CATEGORY: 04–Vertical Penetration
PBS USABLE AREA CATEGORY: Nonassignable Space
PBS SPACE CATEGORY: 10–Unmarketable
PBS SPACE CLASS: Circulation Vertical (CRV)

04–Vertical Penetration

Vertical penetrations are openings between floors, such as passageways for building services, supporting stairs, elevators, flues, pipes, and ducts. To be considered a vertical penetration, the opening must be at least 9 square feet. For vertical penetrations less than 9 square feet, the space should be included with the adjacent space.

Note: This size difference is another area where we differ from ANSI/BOMA.

Illustration 04-1: (diagram to the right) Shows a floor opening with an area of 9 square feet; it is large enough to be assigned as a vertical penetration.

Any floor opening with an area equal to or greater than 9 square feet is large enough to be assigned as a vertical penetration.

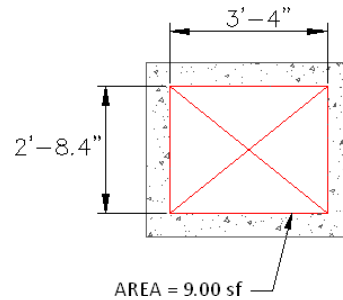

Illustration 04-2: (diagram to the right) Shows a floor opening with an area of 8.89 square feet; it is not large enough to be assigned as a vertical penetration.

Any floor opening with an area of less than 9 square feet is not large enough to be assigned as a vertical penetration.

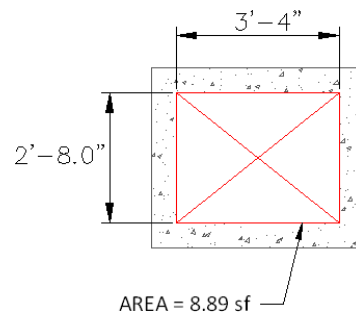
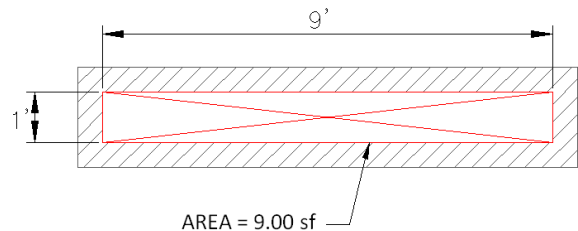

Illustration 04-3: (diagram to the right) When determining whether a floor opening is large enough to be assigned as a vertical penetration, the configuration of the floor opening is not important; all that matters is its area.



The following are typical examples of vertical penetrations and spaces assigned as Circulation Vertical (CRV):

- Public stairs and stair landings
- Public elevator shafts and pits
- Chimneys
- Return/supply air chases
- Vertical ducts
- Pipe shafts

The following are examples of areas that are typically **not** defined as vertical penetrations because they are typically penetrations of less than 9 square feet:

- Sleeved slabs
- Plumbing lines
- Electrical cables
- Telephone distribution lines

Illustration 8: Mechanical Room and Circulation Vertical (CRV)

Note: The mechanical equipment in the figure below determines the height of this room; therefore, both areas are CRVs. This is different for GSA as compared to ANSI/BOMA Z65.1-2017.

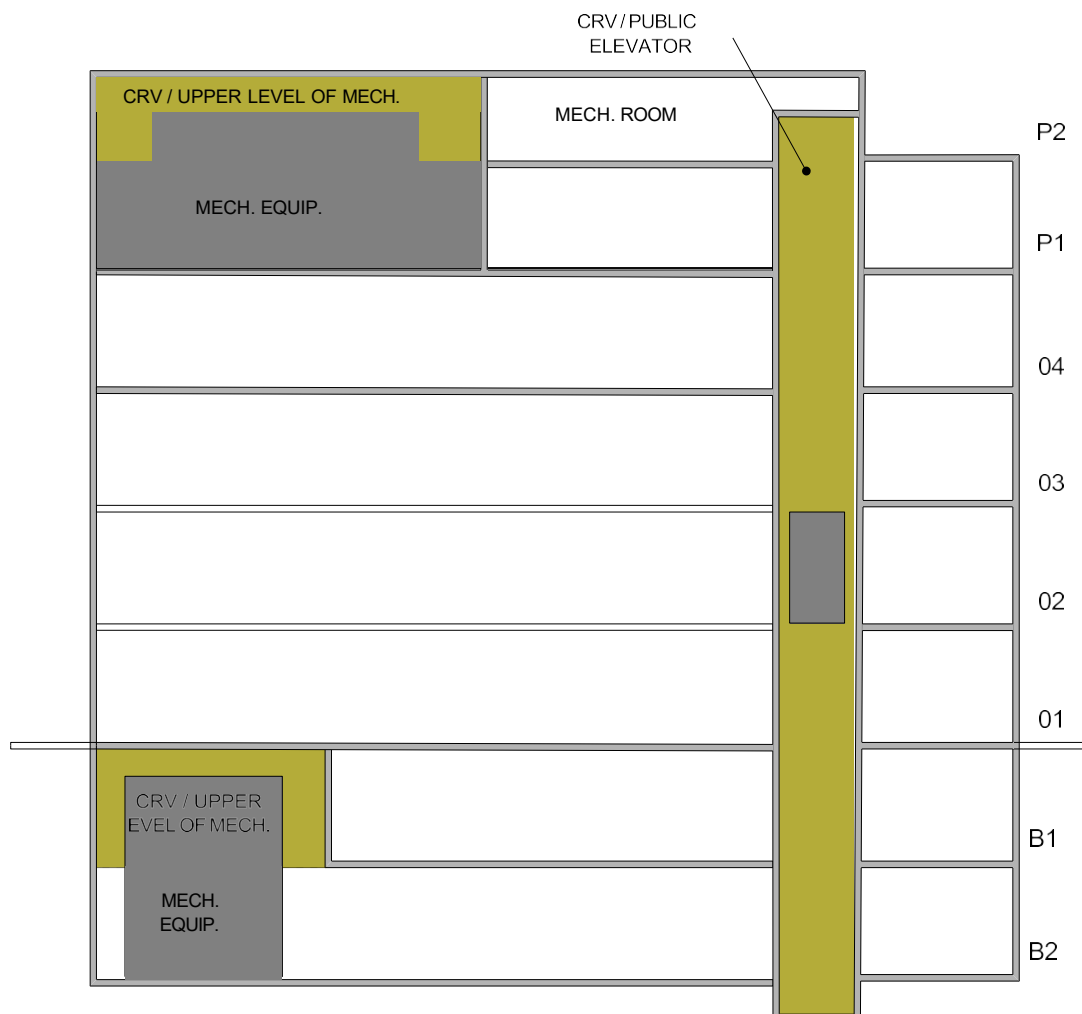

Space Category and Space Class

All space assignments will have a Space Category and a Space Class.

Space Categories are used within the PBS inventory system to identify a room's status of occupancy. The two-digit Space Category numbers are the entries recognized by the PBS inventory system.

Space Class is used within the PBS inventory system to identify a room's build-out. The three-letter Space Class acronyms are the entries recognized within the PBS inventory system.

Notes: Data matrices for the application of Space Categories and Space Class can be found in [Appendix A - Space Assignment Data Matrices](#). Refer to [Appendix B - Methodology Used to Measure Space for placement of space boundaries](#).

Vertical Penetration Space Category

10–Unmarketable

This category identifies all space within the building that is not assignable. Circulation Vertical falls under the space category of Unmarketable.

Vertical Penetration Space Class

CRV–Circulation Vertical

Slab opening that is 9 square feet or greater measured to the inside wall. Circulation Vertical spaces include the following:

- Public stairs and stair landings
- Public elevator shafts and pits
- Chimneys
- Return/supply air chases
- Vertical ducts
- Pipe shafts

Note: Vertical Penetrations not for the private use of an occupant must have the Space Category of 10–Unmarketable, with an AB Code of VERT.

Illustration 9: The colored areas depict Nonassignable Vertical Circulation space and Construction areas. Refer to Illustration 11 for the construction (current wall) details.

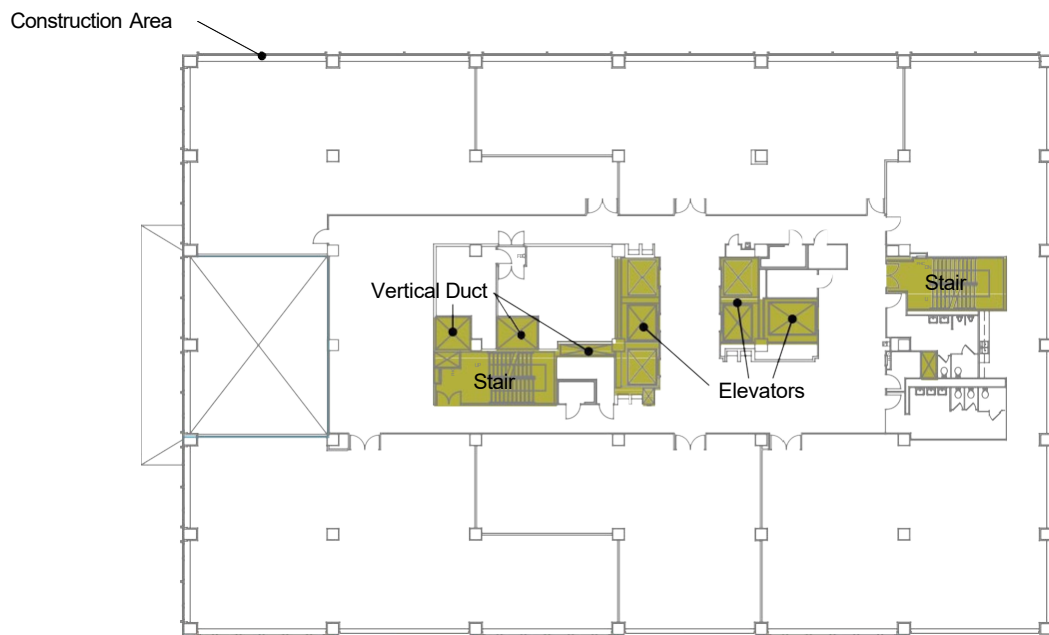

Note: Like Building Common Restrooms, common Vertical Penetrations designed to serve the entire building can become trapped in tenant space. In these rare cases, these elevators and stairs will still be assigned as CRV unless they are part of the occupant requirements under occupant improvements.

Best Practice: See more information under Unique Cases in [Appendix B – Methodology Used to Measure Space](#)

PBS Specific

SDM ANSI CATEGORY: 05–PBS Specific

PBS USABLE AREA CATEGORY: Nonassignable Space or N/A (not measured)

PBS SPACE CATEGORY: 10–Unmarketable, 17–Excluded from Gross, or 14–Zero Square Feet

PBS SPACE CLASS: Multiple—Refer to PBS Space Diagram (Diagram 1)

05–PBS Specific

PBS Specific is an SDM category that PBS has created and defined to cover the areas defined as Nonassignable and N/A (not measured).

- 10 – Unmarketable (Nonassignable)
- 17 – Excluded from Gross (Nonassignable)
- 14 – Zero Square Feet (N/A – not measured)

Note: ANSI/BOMA does not use the SDM Category “PBS Specific”

Nonassignable Space is measured area that is not considered usable, categorized as Unmarketable within a building, and is included in the Gross Area. This includes the following PBS Space Class: Circulation Vertical (CRV); Structured Parking (STP); Unsuitable for Occupancy (UFO); and Construction (CON).

Open to Below is measured but not included in the Gross Area.

Calculation:

$$\text{Nonassignable Space} = \text{Gross Area} - \text{Rentable Area} + \text{Open to Below (Void)}$$

N/A (not measured) Space refers to objects or items that are not measured.

Notes:

1. Private elevators and stairs are assigned and charged to occupants. Public elevators and stairs are not assigned or charged to occupants.
2. Parking is assigned and charged based on the number of parking spaces an occupant uses and not by square footage. Refer to the PBS Pricing Desk Guide and GSA’s Parking Policy for more information.

10–Unmarketable

Unmarketable space is a category of space that cannot be marketed to building occupants because it falls into one of three areas:

- Construction
- Structured Parking
- Unsuitable for Occupancy

Construction Area

Construction area (CON) is the thickness of the outside wall, measured from the interior dominant vertical portion to the exterior dominant vertical portion of the building.

Illustration 10: Three examples with shaded spaces in blue showing Construction area.

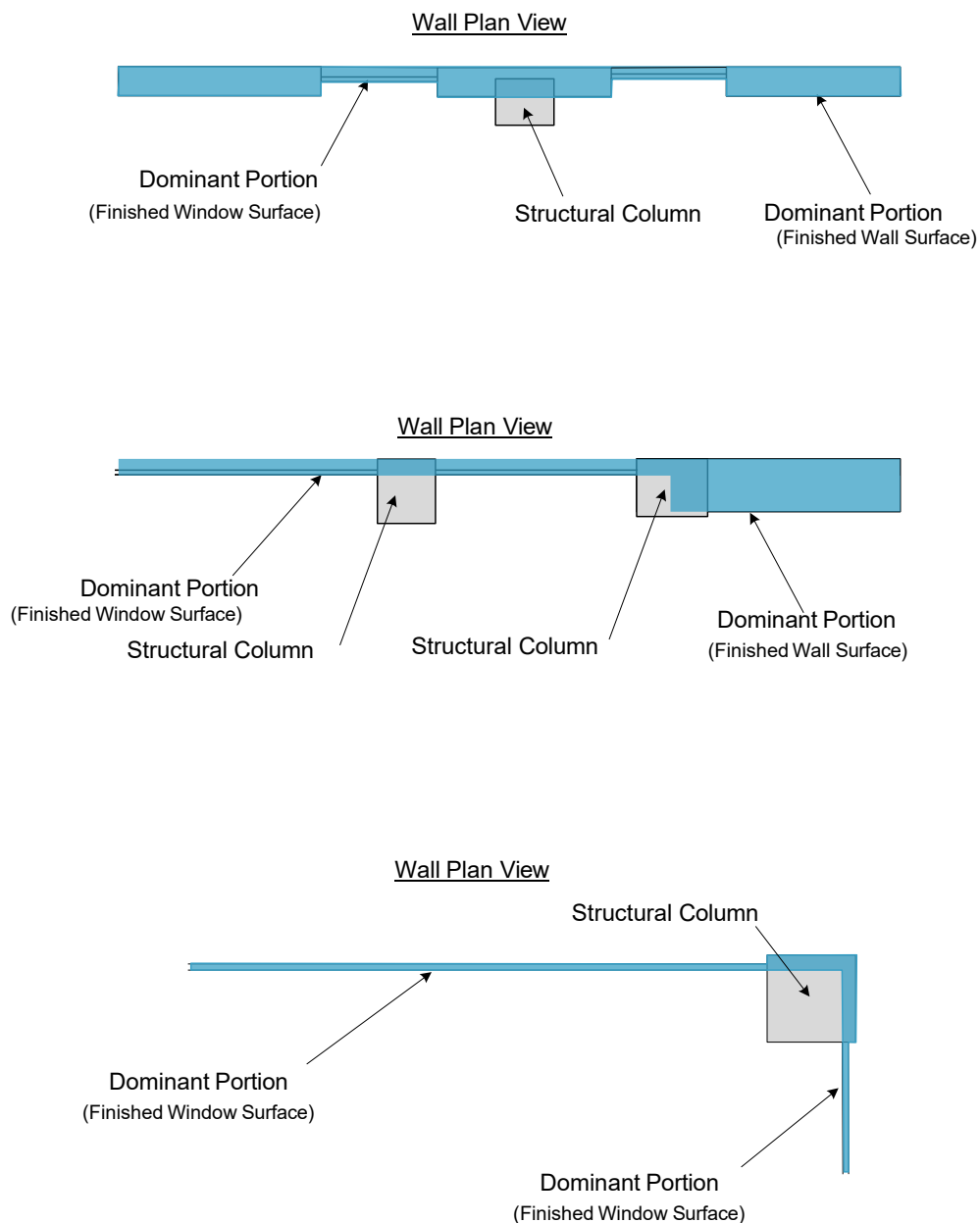

Structured Parking

Structured Parking (STP) is a partially or fully enclosed parking area that resides within a building or as a standalone parking structure. Parking is counted by Square Feet and assigned to the tenant by parking stall as Structured Parking, while the top floor of a parking structure that does not have a roof is not counted by Square Feet but assigned to the tenant by parking stall as Structured Parking.

Notes:

1. Parking is assigned and charged based on the number of parking spaces an occupant uses and not by square footage. Refer to GSA's Parking Policy and PBS' Pricing Desk Guide for more information.
2. If the top floor of a parking structure does not have a roof, it is treated like surface parking.

Illustration 11: Basement floor plan with Structured Parking. The coloring depicts Unmarketable space which includes Vertical Circulation, Parking and Construction.

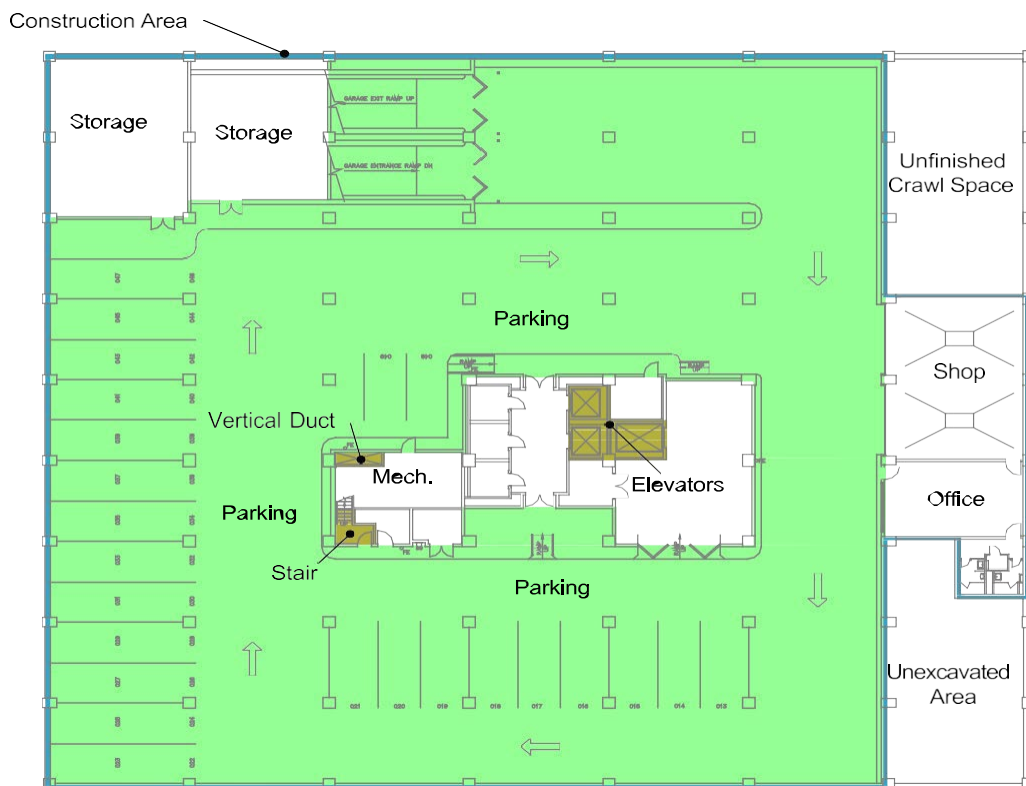

Note: Covered parking or partially covered parking detached from a building that is open on multiple sides is not structured parking and treated as surface parking.

Example (pictured below): Parking covered or partially covered parking with roof and photovoltaic (PV) panels that are open on all sides are not structured parking.



Unsuitable for Occupancy

Unsuitable for Occupancy (UFO) is space in a building that cannot be used for or easily converted to Usable space. If an occupant can use Unsuitable for Occupancy space, it cannot be assigned as UFO.

Types of Unsuitable for Occupancy space may include:

- Space where the ceiling height for the entire area is less than 7 feet. (See [Appendix C - Examples of Special Architectural Situations](#))
- Space that is structurally unstable
- Space where hazardous material has not been removed
- Space that is prone to water damage

UFO space must be approved by the building's regional Asset Manager and sent to SDM Central Office team for concurrence. Include a photo, description of the issue, and drawing showing location.

Note: A space not meeting the Architectural Barriers Act Accessibility Standards (ABAAS) is not automatically considered UFO and needs to be evaluated individually.

17–Excluded from Gross

Excluded from Gross are spaces that will be subtracted from the Gross Area calculation of a building. These areas are Voids and include the upper floor of an Atrium or Lobby.

The measurement and treatment of Voids to match the ANSI-BOMA standards started with buildings whose substantial completion dates were on or after October 1, 2011. For buildings built prior to that, Voids were gradually addressed over a 5-year period beginning with the NBSAP 2013 version. At this time, all building Voids are excluded from the Gross Area per both the ANSI/BOMA standards and the NBSAP.

Note: The following items will be assigned Excluded from Gross Area: ANSI Category 05–PBS Specific, Space Category 17–Excluded from Gross, Space Class–Open to Below (OTB), Agency Name–VOID, and Room Name–Atrium or Open to Below.

Voids

Voids are areas where there is an absence of a floor within a building where a floor might otherwise be expected or measured. Voids are measured at 9 square feet or more (this is slightly different than ANSI/BOMA standards, which specify 10 square feet or greater). Voids are measured to the inside surface and do not include the wall thickness. Absences that are less than 9 square feet are not Voids and should be measured with their adjacent space.

The following areas are Voids:

- Upper floors of an atrium
- Upper floors of a lobby
- Areas adjacent to a mezzanine
- Open to Below areas/spaces (only above common spaces)
- Light wells
- Clerestories (full story or greater)

The ANSI/BOMA definition of Voids is: “Absence of a floor within the exterior enclosure of a building in excess of 10 square feet where a floor might otherwise be expected or measured, that is typically in the plane of the upper floors adjacent to the following Nonassignable spaces: multi-story atria or lobbies, light wells, auditoria or the area adjacent to a partial floor, permanent mezzanine, or unclassified mezzanine at a given floor level”.

Note: Only the lowest floor level of a multi-story space, such as an atrium or lobby is included in the Gross Area. If a stair extends into a Void, all associated levels will remain Circulation Vertical (CRV). GSA PBS uses 9 square feet or greater instead of 10 square feet.

Notes: Voids are distinguished from major vertical penetrations as defined in ANSI/BOMA Z65.1-2010 in that:

1. Major vertical penetrations have a functional purpose, such as allowing passage of building services (HVAC ducts, flues, chutes, dumb-waiters, plumbing, electrical, etc.) or building access and egress (stairs, escalators, elevators, etc.). Whereas Voids only accommodate the need for certain spaces to be higher than adjacent floors.
2. Major vertical penetrations are included in construction gross area and exterior gross area, whereas Voids are excluded.
3. The areas of major vertical penetrations include their enclosing walls, whereas the areas of Voids exclude their enclosing walls. If there is no enclosing wall between a Void and an adjacent floor, the area of the Void extends to the edge of the adjacent floor.

Illustration 12: Example of an atrium. The first floor is the Lobby, the remaining floors are Voids (Open to Below).

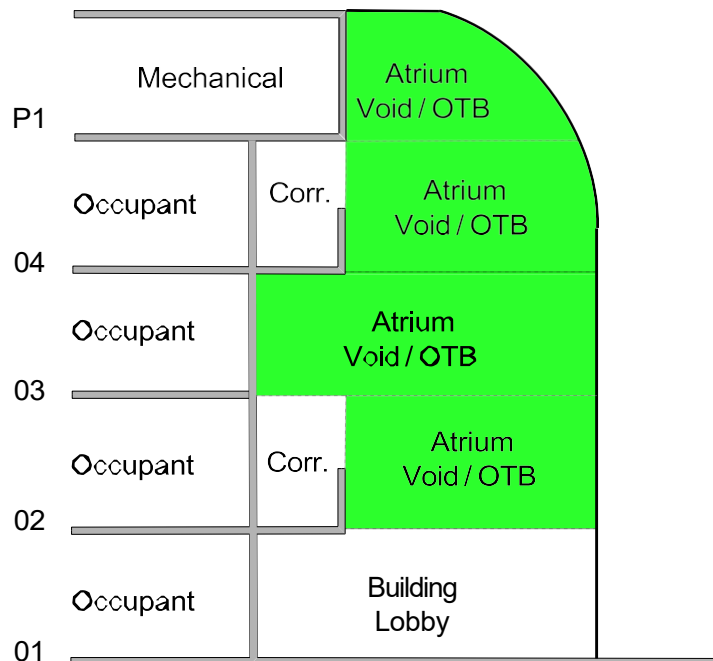

Illustration 13: Example of a multi-storied lobby showing areas considered Voids.

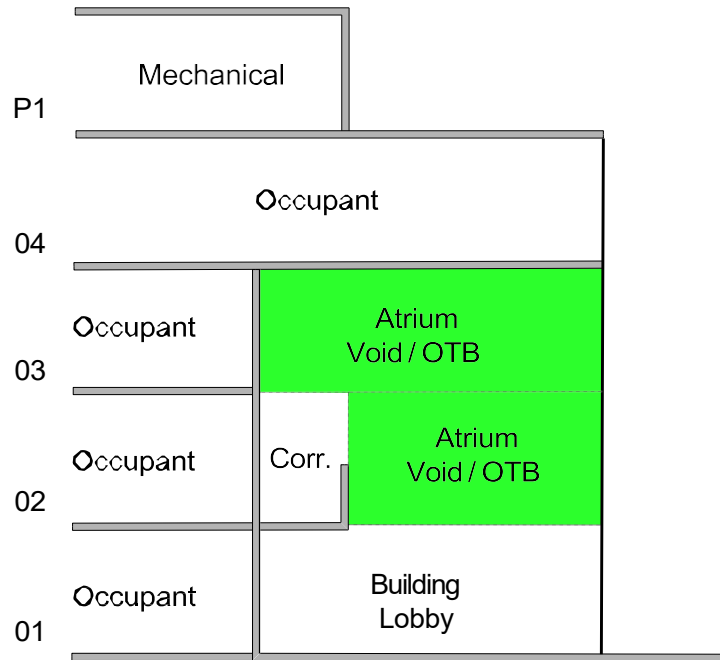

Illustration 14: Example of a multi-storied interior lobby.

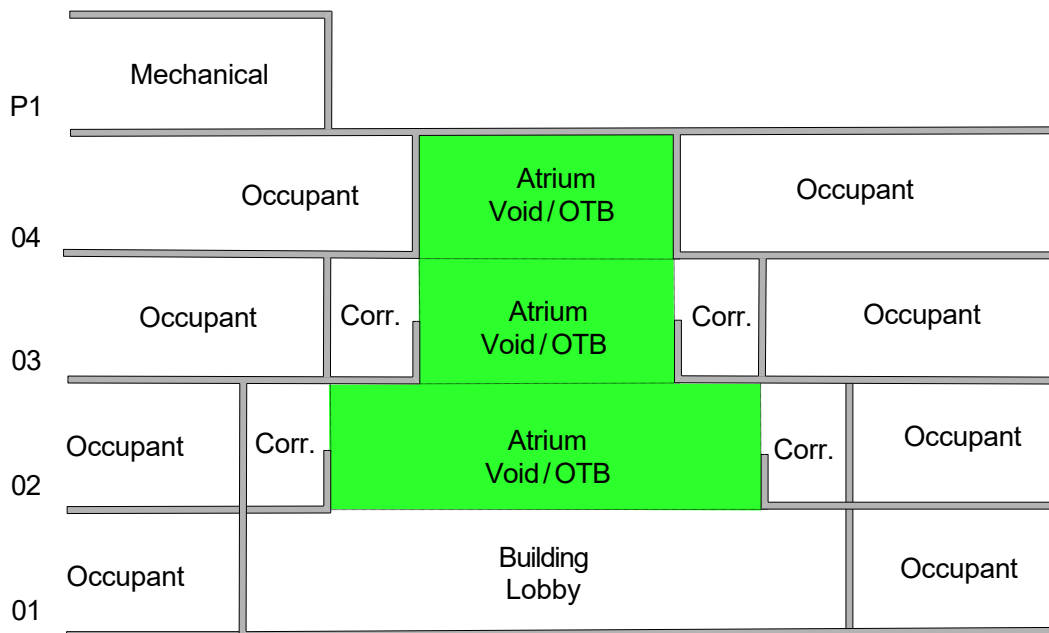

Illustration 15: Example of a clerestory (translucent walls not shown).

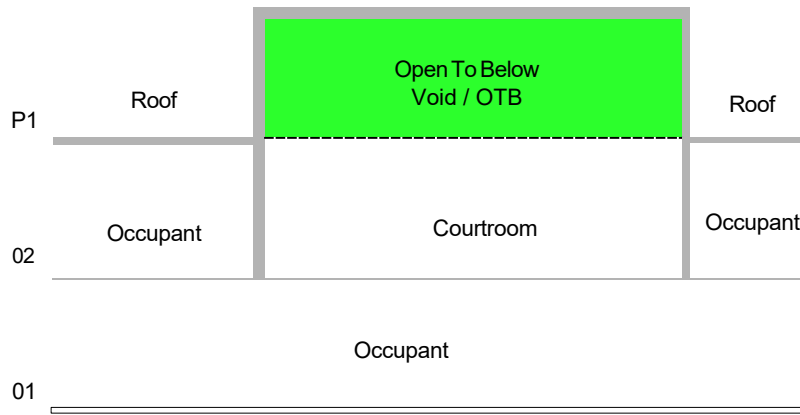

Illustration 16: Example of a Void (spaces on all sides above the Courtroom are non-usable).

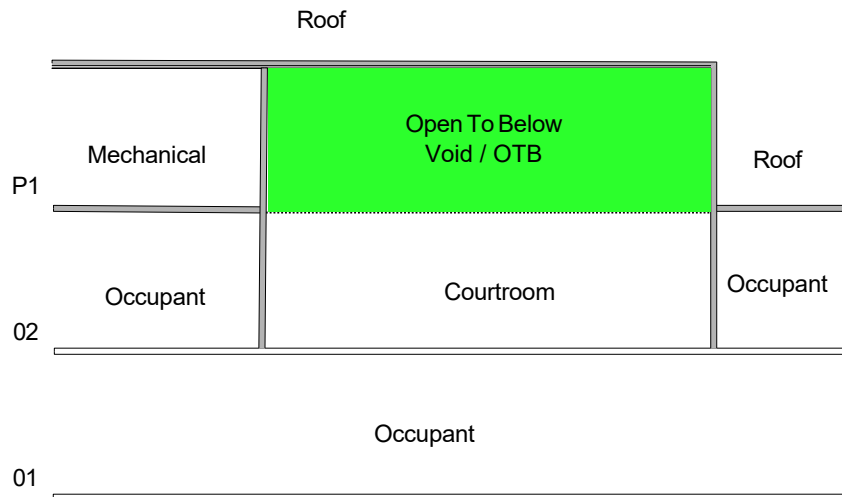
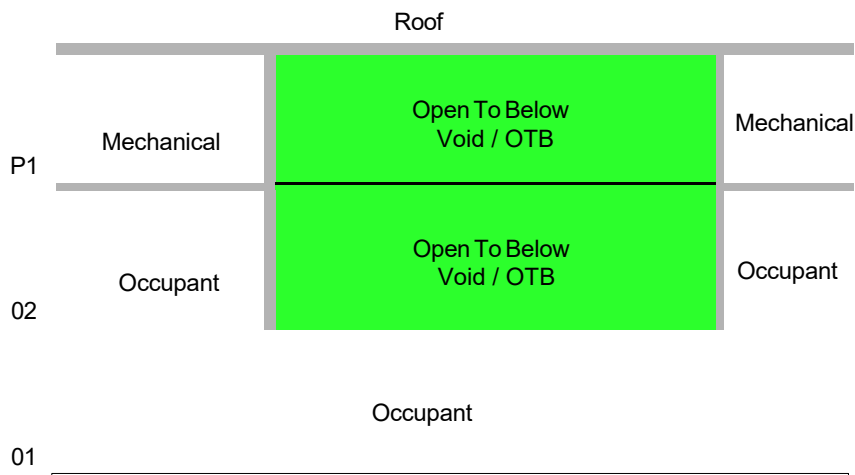

Illustration 17: Example of a Light Chamber. The highlighted light chamber is not included in Gross Area and would be Void (Open to Below).



14–Zero Square Feet

Zero Square Feet items are not measured and have no square footage associated with them. They are identified on drawings with a symbol or text for informational purposes only. An occupant can be assigned Zero Square Feet items and will be charged a fee for those specific Zero Square Foot items.

Examples of items with Zero Square Feet:

- Antenna (ANT)
- Boat Dock (BDK)
- Bridge (BRG)
- Kiosk (KIS)
- Land (LND)
- Other (OTH) – Can include rooftop-mounted wind turbines, solar panels, etc.
- Railroad Crossing (RRC)
- Wareyard (WYD)

Space Category and Space Class

All space assignments will have a Space Category and a Space Class.

Space Categories are used within the PBS inventory system to identify a room's status of occupancy. The two-digit Space Category numbers are the entries recognized by the PBS Inventory system.

Space Class are used within the PBS inventory system to identify a room's build-out. The three-letter Space Class acronyms are the entries recognized within the PBS inventory system.

Notes: Data matrices for the application of Space Categories and Space Class can be found in [Appendix A - Space Assignment Data Matrices](#). Refer to [Appendix B - Methodology Used to Measure Space](#).

PBS Specific Space Categories

10–Unmarketable

Unmarketable identifies all space within a building that is not assignable. Unmarketable Space Class are Construction area, Structured Parking, and Unsuitable for Occupancy.

Note: Circulation Vertical is also an Unmarketable Space Class but is associated with Space Category 04–Vertical Penetration.

Unmarketable Space Class:

CON–Construction Area

Construction area (CON) is the thickness of the outside wall, measured from the interior dominant vertical portion to the exterior dominant vertical portion of the building.

STP–Structured Parking

Structured Parking (STP) is a partially or fully enclosed parking area that resides within a building or is a standalone parking structure. It includes a slab and roof.

UFO–Unsuitable for Occupancy

Unsuitable for Occupancy (UFO) is space in a building that cannot be used for or easily converted to Usable space. If an occupant can make use of Unsuitable for Occupancy space, it cannot be assigned as UFO.

17–Excluded from Gross

Excluded from Gross identifies all space within the building that is not included in the Gross Area. Excluded from Gross Space Class is Open to Below.

Excluded from Gross Space Class:

OTB–Open to Below (Void)

Voids are areas where there is an absence of a floor within a building where a floor might otherwise be expected or measured. Voids are measured at 9 square feet or more (this is slightly different than ANSI/BOMA standards, which uses over 10 square feet). Absences that are less than 9 square feet are not Voids and should be measured (included) with their adjacent space.

14–Zero Square Feet

Special designations for space assignments **not** measured or billed in terms of square feet, such as: antennas, boat docks, bridges, land, railroad crossings, and ware yards. These items are typically not within the building line.

Zero Square Feet Space Class:

ANT–Antenna

Any device located on a Federally owned or leased building or on PBS-controlled land which can be used to transmit and/or receive electromagnetic signals. Included are devices for transmission relay or reception of television, AM/FM radio, or microwave signals. A tower located on PBS-controlled land is **not** an antenna. However, equipment attached to that tower which fits the description (above) is considered an antenna for pricing purposes. We identify the antenna type in our system, the options are dish, whip, satellite, beam, and ground plane.

BDK–Boat Dock

Platform built over water with one end secured to the shore. The platform is used to board and offload small boats, synonymous with a pier or wharf.

BRG–Bridge

Structure built to span a gorge, valley, road, railroad track, river, body of water, or any other physical obstacle. Designs of bridges vary depending on the function of the bridge and the nature of the terrain where the bridge is constructed.

KIS–Kiosk

Located within Common area, a kiosk is a booth with an open window. Some vendors operate from kiosks, selling small, inexpensive consumables such as newspapers, magazines, street maps, and confections.

An information kiosk (or information booth) dispenses free information in the form of maps, pamphlets, other literature, and/or advice offered by an attendant.

An electronic kiosk, computer kiosk, or interactive kiosk houses a computer terminal. Some computer kiosks provide free, informational public service, while others serve a commercial purpose. Touch screens, trackballs, computer keyboards, and push-button input devices are typical for interactive computer kiosks.

LND–Land

Undeveloped areas of property associated with the specific facility or building. These assets may be part of a larger development or may stand alone, but the boundaries must be clearly defined.

OTH–Other

Any element for which an agency must be charged and does not meet the definition of Antenna, Boat Dock, Bridge, Kiosk, Land, Railroad Crossing, or Wareyard. Examples can include rooftop-mounted wind turbines, solar panels, roof gardens, aviaries, etc.

RRC–Railroad Crossing

A crossing, on one level at-grade intersection, without a bridge or tunnel, of a railway line by a road, path, or another railroad. It also applies to a light rail line with separate rights-of-way (or a reserved track tramway) that crosses a road.

WYD–Wareyard

Land assigned to an occupant that is adjacent to a building within a fenced or secured area.

Structures

Structures are not buildings, rather large antennas, platforms, weather station equipment, etc. that sit on a site and are located within the boundary of the site. Sometimes a structure, such as an antenna tower, will hold multiple antennas so there are multiple point objects on or near the structure, this is because GSA charges by the number of individual antennas as detailed above under zero square feet spaces.

For antennas or such other types of equipment an antenna charge will be assessed if it sits on the property site and the surface covers 100 sq. ft or less and its removal would not cause any damage. If any type of equipment operations structure is additionally involved and is attached to the surface with a footing or foundation, or any constructed accessory extends below the surface of the property, land rent will be charged.

A small 8' x 8' tool/storage shed (usually on skids) that can be picked up with a forklift and moved is personal property and putting each tool/storage shed in GSA's parking lot is equivalent to the rent charge for one surface parking space per shed.

Examples of Structures:



Photograph STR-1: This photograph is an example of tide monitoring station.

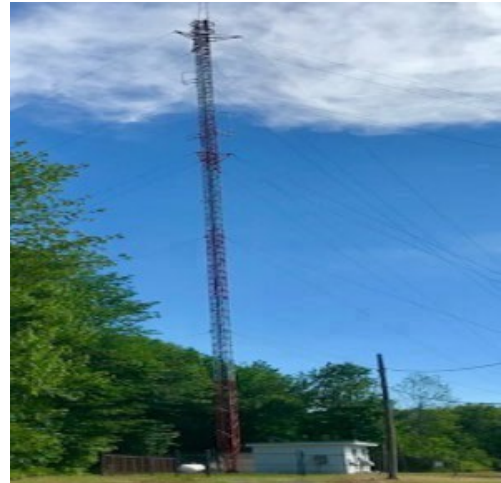

Photograph STR-2: This photograph is an example of an antenna tower which holds multiple antennas.

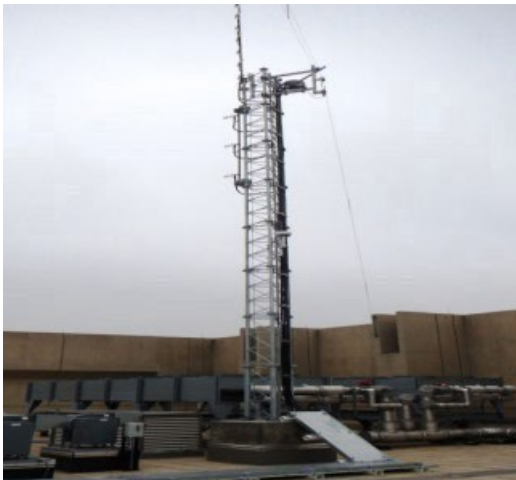

Photograph STR-3: This photograph is an example of a large stand-alone antenna with its associated communications building in the foreground

Note: The dedicated Communications Building is a building because it has a roof and a slab.

Space Assignment Room Name Application and Definitions

SDM uses room names to indicate how the rooms are being used. Room names are independent of the Space Class assignment and business decisions should not be based solely on the room name.

SDM is now using the Omniclass Table 13 room names with some added entries to accommodate some unique rooms.

For reference, a crosswalk between the old room names and the Omniclass room names can be found in [Appendix H – Old Room Name Crosswalk with Omniclass](#)

Application of Room Names for Assignment Drawings

- Room names must represent the predominant use of the space.
- Use the room name *Undefined* until the room name is known.
- The following room names are the only valid entries for use with assignment drawings.

Omniclass Table 13 - Spaces by Function

Level 1 Title	Level 2 Title	Level 3 Title	Level 4 Title	Definition
Space Planning Types				Amounts of space establish for development of design scenarios
	Planned Work Space			Spaces planned to perform a function in support of the occupant business objectives.
	Planned Building Service Space			Spaces planned to support the operation of the building enabling the occupants to work in a safe and supportive environment.
	Planned Amenity/Support Space			Spaces planned to be provided as a convenience offering occupants support beyond their business driven functional requirements.
	Planned Circulation Space			Spaces planned for circulation to provide or control access to and between other spaces within the facility, entry, and egress.
	Planned Parking Space			Spaces planned to be used to circulate and station vehicles.
Void Areas				A space inside the building where floor structure might otherwise be expected. The lowest floor of a multi-story void is classified based on the utilization at that level.

Level 1 Title	Level 2 Title	Level 3 Title	Level 4 Title	Definition
	Light Well			Multi-story, enclosed space in a building, which may have a skylight. Every level of the atrium
	Air Shaft			A vertical (or near vertical) shaft that supplies ventilation to a tunnel or other underground facility
	Occupant Void Area			Opening in a floor created for the specific benefit of an occupant.
Wall Spaces				The space taken up by any of various permanent upright constructions having a length much greater than the thickness and presenting a continuous surface except where pierced by doors, windows, etc.: used for shelter, protection, or privacy, or to subdivide interior space, to support floors, roofs, or the like.
	Exterior Wall Space			The space of a wall that divides/separates inside spaces from out side spaces. The wall may be structural or non-structural
	Interior Wall Space			The space of a wall that divides/separates inside spaces only. The wall may be structural or non-structural
Encroachment Spaces				The space associated with base building elements that prevent the use of the space for furniture, equipment, circulation, or other occupant function.
	Interior Encroachment			The space associated with a base building element that is located inside the building but not on the outer wall.
	Perimeter Encroachment			The space associated with a base building element that is located on the outer wall.
Parking Spaces				Spaces used to circulate and station vehicles.
	Exterior Parking Spaces			Outdoor area used for transient storage of motor vehicles, not including loading docks, sally ports and building service areas such as enclosed auxiliary lobbies used to enter a building from parking areas.
		Exterior Parking Circulation		Outdoor space used to circulate vehicles and providing access to parking stalls.
		Exterior Parking Access Control Point		Outdoor parking access control point space such as attendant booth, gate, card reader, or self serve ticket dispenser.
		Exterior Parking Stall		Outdoor space provided for parking a vehicle (car, truck, bicycles or motorbikes).

Level 1 Title	Level 2 Title	Level 3 Title	Level 4 Title	Definition
	Interior Parking Spaces			Totally or partially enclosed space that is normally used to circulate and station vehicles.
		Interior Parking Ramp and Circulation		Interior space including ramps used to circulate vehicles and providing access to parking stalls.
		Interior Parking Access Control Point		Interior parking access control point space such as attendant booth, gate, card reader, or self serve ticket dispenser.
		Interior Parking Stall		Interior space provided for parking a vehicle (car, truck, bicycles or motorbikes).
		Interior Vehicle Service Space		Interior parking stall and circulation space used to provide vehicle services.
Facility Service Spaces				Portion of a building that provides services that enable occupants to work in a building
	Vertical Penetration			Opening in a floor that serves a building or system distribution function
		Mechanical Circulation		Space used by mechanical modes of circulation such as elevators and escalators providing transportation between floors of a structure.
			Elevator Shaft	An enclosed space extending through one or more stories of a building connecting vertical openings in successive floors, or floors and the roof used to enclose an elevator.
			Elevator Pit	
			Elevator Cab	Platform or an enclosure raised and lowered in a vertical shaft to transport people or freight.
			Elevator Machine Room	A room to house elevator motors, pumps, controls or lifting equipment
			Dumbwaiter	A small lift / elevator used to move food etc. from one floor of a building to another.
			Escalator	Set of moving steps attached to a continuously circulating belt that carries people up or down between levels in a building.
			Freight Elevator	Device for vertical transportation of freight to different floors or levels in a building
		Stairway		Space used by a static circulation path providing transportation between floors of a structure.

Level 1 Title	Level 2 Title	Level 3 Title	Level 4 Title	Definition
			Egress Stairway	A stair that is part of an exit or leads to an exit.
			Tenant Stairway	A stair that is accessible only by the tenant
		Monumental Stair		Space occupied by a larger than necessary, architectural stair. Space with clear headroom under the stair may be classified differently.
		Ramp		A walking surface that has a running slope steeper than 1 unit vertical in 20 units horizontal (5-percent slope). (IBC)
		Chimney		a primarily vertical enclosure containing one or more passageways for conveying flue gasses to the outside atmosphere.
		Chute		(postal, refuse, laundry) which end at a "termination room" - a shaft enclosure that does not extend to the underside of the roof sheathing, deck, or slab of the building.
		Service Riser Space		Space used to accommodate intra-floor services such as flues, fire towers, fire hose cabinets (because of the pipes attached to them), stacks, pipe shafts, electricity, vertical air conditioning ducts and other vertical ducts.
			Power Distribution Riser	A vertical service pipe or duct providing a route for electrical cabling to service floors with electricity
			Information Signal Distribution Riser	A vertical service pipe or duct providing a route for communication cabling to service floors with tele and/or data communications
			Gas Distribution Riser	A vertical service pipe or duct providing a route for gas piping to service floors with gas.
			Liquid Distribution Riser	A vertical service pipe or duct providing a route for piping to service floors with water and/or other liquids
	Horizontal Infrastructure/Service Space, Non-Occupied			Space solely used to accommodate horizontal distribution of infrastructure for HVAC, Power and Communications. Within Interstitial space the tracking of horizontal distribution is optional. Generally the final distribution such as electrical circuits within an office area are not tracked.
		Power Distribution Network		A horizontal space providing a route to distribute electricity on a floor
		Information Signal Network		A horizontal space providing a route to distribute tele and/or data communications on a floor
		Gas Distribution Network		A horizontal space providing a route to distribute gas on a floor

Level 1 Title	Level 2 Title	Level 3 Title	Level 4 Title	Definition
		Liquid Distribution Spaces		A horizontal space providing a route to distribute water and/or other liquids on a floor
	Control Room			Space used for the control and monitoring of life safety and communication services.
		Fire Command Center		Space for fire department operations with the location, layout, content and features and approved by the fire department; includes Fire Protection System (FPS)
		Guard Stations		Booth or room within building line used to house security for building or tenant.
	Loading Dock			A secondary building entrance space used to accommodate shipping and delivery of bulk materials to the structure.
	Restroom			A space with washing and toilet facilities.
		Mens Restroom		Toilet(s) used exclusively by men.
		Womens Restroom		Toilet(s) used exclusively by women.
		Unisex Restroom		Handicapped toilet for individual use by men or women, or for family use.
		Lactation Room		Private room for nursing mothers, typically including a refrigerator, sink, cleaning supplies, table and comfortable chair
	Utility Equipment Room			Space provided for the general operation of heating, ventilating, and air conditioning, plumbing and electrical, life safety and communication services; including sections of tunnels which are dedicated to distribution of utilities.
		Refrigerant Machinery Room		A room meeting prescribed safety requirements and in which refrigeration systems or components thereof are located.
		Furnace Room		A room primarily utilized for the installation of fuel-burning, space-heating and water-heating appliances other than boilers.
		Incinerator Room		A room used for reducing combustible refuse material to ashes.
		Fuel Room		A separately ventilated, fully enclosed room for the storage of fuel
		Gas Room		A separately ventilated, fully enclosed room in which only compressed gases and associated equipment and supplies are stored or used

Level 1 Title	Level 2 Title	Level 3 Title	Level 4 Title	Definition
		Liquid Storage Room		A room classified as a Group H-3 occupancy used for the storage of flammable or combustible liquids in a closed condition
		Liquid Use, Dispensing and Mixing Room		A room in which Class I, II, and IIIA flammable or combustible liquids are used, dispensed or mixed in open containers
		Hydrogen Cutoff Room		an assembly of piping, devices and apparatus designed to generate, store, contain, distribute or transport a nontoxic, gaseous hydrogen containing mixture
		Electrical Room		A designated room containing electrical equipment.
		Switch Room		Contains electrical switch gear and equipment.
		Telecommunications Room		A designated room containing telecommunications equipment.
		Transformer Vault		A separately ventilated, fully enclosed room to house the building power transformer
	Waste and Recycling Spaces			Space used for holding garbage and recyclable materials.
		Hazardous Waste Storage		An area used for the storage of chemicals or substances that pose a physical or health hazard that are in waste condition.
	Building Service Support Spaces			Other building service space, such as space used for the building operator and custodian office, workshop and supplies.
		Building Manager Office		Space for the property manager
		Custodial Space		Room that contains sink(s) or mop sink(s) and is used by custodial services for CUST. their related activities.
		Shop Area		A place where things are crafted
		Access Chamber		Space that leads to prefabricated sewage system "man hole" structures
		Areaway		A subsurface space adjacent to a building open at the top or protected at the top by a grating or guard
		Service Space		Clear floor space in front of an appliance to assure adequate space for servicing.

Level 1 Title	Level 2 Title	Level 3 Title	Level 4 Title	Definition
		Furred Space		Furred-out space is created when the floor layout must accommodate irregular wall surfaces or conceal mechanical obstructions.
		Crawl Space		Unexcavated space that has restricted headroom and is not occupiable.
		Attic Space		The space between the ceiling beams of the top story and the roof rafters.
		Plenum		A horizontal chamber intended to contain air, gas, or liquid at positive pressure
	Equipment Platform			An unoccupied elevated platform used exclusively for mechanical systems or industrial process equipment, including the associated elevated walkways, stairs and ladders necessary to access the platform.
	Interstitial Space			The area of load bearing surfaces located above or below occupied building floor that are not available for general occupancy often due to inadequate clear headroom and contain building mechanical or electrical systems predominantly serving the adjacent floors or to provide access to such systems.
	Unimproved Shell			The portion of a building that has been constructed with minimal enclosure for future use.
	Alteration or Conversion Space			Spaces temporarily out of use because they are being altered, remodeled, or rehabilitated at the time of the inventory.
Circulation Spaces				Spaces for circulation that provide or control access to and between other spaces within the facility, entry, and egress.
	Primary Circulation Spaces			The direct path on a floor necessary for access to egress stairs, elevator lobbies, toilet rooms, refuge space, building lobbies and entrances.
		Corridor		An enclosed exit access component that defines and provides a path of egress travel to an exit.
		Aisle		An exit access component that defines and provides a path of egress travel.
		Mall		A roofed or covered common pedestrian area within a covered mall building that serves as access for two or more tenants.
		Concourse		A large open space in a building where people can gather.

Level 1 Title	Level 2 Title	Level 3 Title	Level 4 Title	Definition
		Breezeway		A structure with a roof and open sides that connects two buildings.
		Moving Walkway		A slow conveyor belt that transports people horizontally or on an incline in a similar manner to an escalator.
	Transitional Circulation Spaces			Space adjacent to the entry points such as lobbies.
		Entry Vestibule		A passage, hall or room between the outer door and the interior of a building
		Entry Lobby		A large entrance area of hall that serves as a foyer
		Lobby		Entranceway or foyer within the building line.
		Vestibule		A small passage, hall, or room between a door or room and another room, corridor, or lobby
		Elevator Lobby		Lobby that separates the elevator shaft enclosure doors from each floor by fire partitions.
		Freight Elevator Vestibule		A small passage, hall, or room between a door or room and a freight elevator.
		Landing		An in-between platform or large bottom-most or top-most step of a staircase
		Anteroom		A room before, or forming an entrance to, another
		Air Lock		An airlock is a device which permits the passage of people and objects between a pressure vessel and its surroundings while minimizing the change of pressure in the vessel and loss of air from it. The lock consists of a small chamber with two airtight doors in series which do not open simultaneously.
		Sally Port		A small controlled space with two doors. Access requires that one door must remain closed to proceed, used for security.
		Jet Way		An enclosed, telescoping, movable ramplike bridge connecting an airport terminal and an aircraft, for use by passengers in boarding and disembarking.
	Connector			A covered or enclosed bridge, walk-way, tunnel or other similar connecting element between two separate buildings.

Level 1 Title	Level 2 Title	Level 3 Title	Level 4 Title	Definition
	External Circulation Spaces			Unenclosed corridors meeting circulation and exiting requirements of the local building code, and only when there are no fully enclosed corridors on a Floor that provide that function..
	Secondary Circulation Spaces			A portion of a floor required for access to some subdivision of the floor, that does not serve all occupants on a floor, and is not defined as primary circulation Space.
		Door Set-Back		A recess in a vertical wall plane that contains an access and egress to a tenant area, or amenity area, or building service area.
	Restricted Spaces			Space that is normally available for use but is set aside by regulatory authority, such as clear space requirements for electrical closets.
	Refuge Spaces			An enclosed space that is protected from the effects of fire permitting a delay in required egress travel time.
Education and Training Spaces				Space used for education.
	Breakout Space			A space associated with a classroom or training room that is designated for discussions, side meetings, and breaks.
	Lecture and Classroom Spaces			Spaces used for classes, lectures, symposiums, and speeches.
		Lecture Classroom		A room in which teaching or learning activities can take place.
		Classrooms (age 9 plus)		A room in which teaching or learning activities can take place for older children, ages 9 and over.
		Classrooms (ages 5–8)		A room in which teaching or learning activities can take place for younger children, ages 8 and younger.
		Lecture Hall (Fixed Seats)		A large room used for instruction, typically at a college or university, with a capacity in the hundreds.
		Assembly Hall		A hall where many students and teachers can congregate.
		Seminar Room		A space for conducting a course offered for a small group of advanced students.

Level 1 Title	Level 2 Title	Level 3 Title	Level 4 Title	Definition
	Class Laboratories			A space used primarily for formally or regularly scheduled instruction that require special purpose equipment or a specific space configuration for student participation, experimentation, observation, or practice in an academic discipline.
		Open Class Laboratory		An educational space that provides controlled conditions in which scientific research, experiments, and measurement may be performed for teaching purposes.
			Physics Teaching Laboratory	An educational laboratory space for teaching physics through hands on experimentation and demonstration.
			Astronomy Teaching Laboratory	An educational laboratory space for teaching astronomy through hands on experimentation and demonstration. May require a planetarium and rooftop observation platforms.
		Research/non-class Class Laboratory		A space used for laboratory experimentation, research, or training in research methods; professional research and observation; or structured creative activity within a specific program or for sponsored research.
		Laboratory Service Space		A space that directly serves one or more class laboratories as an extension of the activities in those spaces.
	Training Spaces			Space that is similar in configuration to a classroom but which contains specialized equipment or machinery used as part of a specific training activity.
		Computer Lab		Space, often found in libraries, schools, government buildings, science labs, or community centers, which contains many networked computers and may contain printers, scanners, or other peripherals for public use.
		Woodshop/Metal shop		A room for providing vocational education and training in the skills needed to perform a particular job, such as wood or metal working.
		Training Support Space		Space which is used for support services directly related to training activities.
		Religious Education Space		Space for training of those who perform or administer religious rites, both laypeople and clergy.
	Study Spaces			Spaces in which learning or experimentation take place.
		Study Room		A room or area used by individuals to study at their convenience, the space not being restricted to a particular subject or discipline by contained equipment.

Level 1 Title	Level 2 Title	Level 3 Title	Level 4 Title	Definition
		Study Service		A space that directly serves study spaces, stacks, open-stack study spaces, or processing rooms as a direct extension of the activities in those spaces. stack and study areas.
Recreation Spaces				A space for any leisure activity, such as play, that diverts, amuses or stimulates.
	Athletic Recreation Spaces			Spaces for participating in sports and athletic activities.
		Athletic Spectator Seating		The covered seating area used by students, staff, or the public to watch athletic events.
			Bleacher	A seating section commonly found in athletic spaces but occasionally found in performance spaces, containing bench seating instead of separate seats.
		Team Athletic Recreation Spaces		Spaces for participating in team sports and athletic activities.
			Baseball Field	A playing field on which the game of baseball is played.
			Softball Fields	A playing field on which the game of softball is played. See also Baseball Field
			Dugouts	A sunken shelter at the side of a baseball or football (soccer) field where non-playing team members sit.
			Grass Playing Fields	A grass field on which a game, esp. a ball game, is played.
			Synthetic Fields	A field, often used for team sports, planted with a synthetic grass substitute.
			Football Field	A playing field on which the game of American football is played. Also used as an informal measurement of size.
			Soccer Field	A playing field on which the game of soccer is played.
			Basketball Courts	A concreted outside area or tiled or wooden inside area on which the game of basketball is played.
			Field Light Poles	Spaces for lighting equipment used to illuminate a team sport playfield.
			Press Box	The section in a stadium or arena set aside for the press, or specifically for sportscasters.
			Scoreboards	A large board that displays the score in a game or contest.
		Individual Athletic Recreation Spaces		Spaces for participating in individual sports and athletic activities.

Level 1 Title	Level 2 Title	Level 3 Title	Level 4 Title	Definition
			Hard Playing Surfaces	Hard-surfaced spaces used for individual or team recreation, such as playgrounds.
			Tennis Courts	A firm, rectangular surface, marked with lines and having a net across the middle, where the game of tennis is played.
			Volleyball Court	A rectangular surface marked with lines and having a high net across the middle, where the game of volleyball is played.
			Golf Course	A grassy course consisting of series of holes, each with a teeing ground, fairway, rough and other hazards, and a green with a pin and cup, all designed for the game of golf.
			Driving Range	A facility for practicing driving golf balls.
			Golf Course Support Space	Spaces designed to support golf courses on the installation. Space may include equipment storage and maintenance areas, locker rooms, and equipment sales area.
			Skating Rink	A specially frozen surface of water on which people skate or play ice hockey.
			Boxing Ring	A space, usually square, with elastic ropes around the edge, in which a boxing match is competed.
			Wrestling Mat	A space in which a wrestling match is competed.
			Diving Board	A springboard used for diving into water
			Bowling Lane	A space in which players attempt to score points by rolling a bowling ball along a flat surface into objects called pins.
			Dart Throwing Area	A space in which darts can be thrown at a circular target (dartboard) hung on a wall.
			Circuit Training Course Area	A space for interval training in which strength exercises are combined with endurance/aerobic exercises.
			Running Tracks	A track for holding running events at track and field competitions.
			Ski Lift Space	Space for a device that transports skiers up a mountain.
			Exercise Space	A space to perform physical activity intended to improve strength and fitness.
			Workout Station	A space for a machine designed to enable exercise to enhance or maintain physical fitness and overall health.
			Aerobic Studio	A space for a form of exercise, designed to enhance one's cardiovascular fitness, often performed to music.
			Climbing Wall	An artificial wall used for the sport of climbing.

Level 1 Title	Level 2 Title	Level 3 Title	Level 4 Title	Definition
			Ropes Course Elements	A challenging outdoor personal development and team building activity which usually consists of elements of varying height connected by rope bridges that must be traversed.
	Swimming Pools			
		Outdoor Swimming Pool		Non-enclosed swimming pools intended for recreational use. See also: Indoor Swimming Pool
		Indoor Swimming Pool		An artificially enclosed body of water intended for swimming or water-based recreation, designed for year-round use. See also: Outdoor Swimming Pool
			Diving Tank	A water-filled structure for training related to SCUBA diving.
	Non-Athletic Recreation Spaces			Spaces for recreation and entertainment that do not include athletic activity or sports.
		Park		A tract of ground kept in its natural state, about or adjacent to a residence, as for the preservation of game, for walking, riding, or the like or a piece of ground, in or near a city or town, enclosed and kept for ornament and recreation; as, Hyde Park in London; Central Park in New York.
		Pleasure Garden		A garden that is opened to the public for recreation, differentiated from other public gardens by containing entertainments in addition to the planting; for example, concert halls or bandstands, rides, zoos or menageries.
		Firing Range and Shoot House (High Risk Operation)		A training facility designed specifically for small arms ammunition weapons qualifications using live-fire, electronic or eco-friendly ammunition. Ranges are used exclusively by law enforcement agencies for the purpose of proficiency testing and certification. For High Risk Operation space, a shoot house is also viewed as another form of firing range.
		Indoor Firing Range		Indoor firing ranges provide marksmanship training space for the firing of pistols and small caliber rifles.
		Outdoor Shooting Range		A training range for the firing of small arms
		Recreational Deck		Wood or timber flat surface capable of supporting weight and used in a number of ways - as part of garden landscaping, to extend living areas of houses, and as an alternative to stone based features such as patios.

Level 1 Title	Level 2 Title	Level 3 Title	Level 4 Title	Definition
		Playground		A large open space where children play or small area for children with dedicated play equipment - slide, or tubes, or swings, etc.
		Game Room		A room used for a variety of purposes, such as parties, games and other everyday or casual use.
		Gambling Table		A table where games of chance such as poker, craps, or roulette are played and bet upon.
		Amusement Ride		A device found at carnivals, fairs/funfairs, or amusement parks meant to appeal to various senses of the rider.
		Parade Grounds		A large area of hard ground, usually of concrete or tarmac, where soldiers practice routine marching maneuvers.
		Computer-Aided Visual Environment		A space for projecting an apparent reality that is only based in the computer.
		Hobby and Craft Center		A facility that provide space for administration, drawing and art studio, storage, photo dark room, audio/photo sales area, separate areas for individual crafts and arts, and kiln area for ceramics.
		Dance Floors		A dance floor construction, which may include a sprung floor, flooring typically made of vinyl sheeting, also called a marley floor, or an illuminated dance floor, also called a disco dance floor.
	Wellness Spaces			Space that is related to medical and other wellness services provided to the personnel in a facility; such as first aid stations.
		Fitness Center		Spaces for exercise and fitness activities.
			Exercise Room	Space used for physical wellness but does not include weight-lifting equipment
			Weight Room	Space used for weight-lifting, either using exercise equipment or free weights.
Government Spaces				A place provided for general public access and use.
	Judicial Spaces			Spaces supporting the work of the justice system.
		Courtroom		The room where a judge presides over hearings and trials, sometimes with a jury
			Jury Box	The area in a courtroom wherein the jury is seated during a trial.

Level 1 Title	Level 2 Title	Level 3 Title	Level 4 Title	Definition
			Jury Room	The room where a jury is sequestered and deliberates at the close of a trial.
			Judges Bench	The location in a courtroom where a judge sits.
			Jury Assembly Space	Room where prospective jurors gather to wait or assemble before being selected for jury duty. Includes seating area and may include TV, work stations, and tables.
			Witness Stand	An enclosed area in a courtroom where witnesses give their evidence.
		Judges Chambers		The office of a judge.
			Law Clerk Space	Space for a law clerk that assists a judge.
		Robing Area/Room		Space for judges to change into their robes.
		Hearing Room		Room used by courts and administrative agencies as a location where evidence and testimony is submitted for findings of fact. May be closed or open.
	Legislative Spaces			Spaces supporting the legislative assemblies of government.
		Council Chambers		A specialized meeting space generally associated with local government facilities. The space is designed to allow councilors to interact face to face and includes gallery space for citizens.
		Legislative Hearing Room		Room where members of legislative bodies and their committees and subcommittees hold hearings for receipt of testimony and evidence in reference to action on legislation. Typically has audience space.
	Military Spaces			Spaces associated with Military training functions
		Armory		A room or area used by Reserve Officer Training Corps (ROTC) and ancillary units for military training and/or instructional activities.
		Armory Service Space		A space that directly serves an armory facility as an extension of the activities in that facility.
	Ports of Entry (POE)			Spaces associated with places where one may lawfully enter a country.
		Land Ports of Entry (LPOE)		Spaces associated with land-based entry points, through which pedestrians, vehicles and/or animals may pass.
			Hazardous Waste Canopy	An overhead roof or structure that is able to provide shade or shelter over an area used for the inspection of hazardous materials.

Level 1 Title	Level 2 Title	Level 3 Title	Level 4 Title	Definition
			High-throughput Cargo Inspection	High-throughput cargo screening area used for non-invasive vehicular and cargo inspection.
			Inspection Booth	Free-standing booth or structure used to house vehicular traffic inspection personnel.
			Pedestrian Processing	Primary or secondary inspection areas for processing pedestrian traffic entering the country.
			Pedestrian Walkway	Waiting area for pedestrian traffic entering the country, located prior to entering pedestrian processing areas.
			Pre-Primary Inspection	Waiting area for vehicular traffic entering the country, located prior to entering primary inspection booths.
			Primary Canopy	An overhead roof or structure that is able to provide shade or shelter over the main vehicular entry point.
			Primary Inspection Canopy	An overhead roof or structure that is able to provide shade or shelter over an area utilized by vehicular traffic inspection personnel.
			Primary Truck Inspection Canopy	An overhead roof or structure and/or booths that are able to provide shade or shelter over an area utilized by commercial vehicular traffic inspection personnel.
			Secondary Inspection Canopy	An overhead roof or structure that is able to provide shade or shelter over an area used for more thorough vehicular inspection.
			Secondary Truck Inspection Canopy	An overhead roof or structure and/or docks that are able to provide shade or shelter over an area utilized for more thorough commercial vehicular traffic inspection.
Artistic Spaces				
	Performance Spaces			Space used for any performance type such as dance, music or theater.
		Outdoor Theater		An outdoor facility to accommodate cultural events such as plays, concerts, and festivals.
		General Performance Spaces		A space for events in which performers perform for an audience.
			Acting Stage	A space for the performance of theatrical productions.
			Orchestra Pit	The area in a theater, usually located in a lowered area in front of the stage, in which musicians perform.
			Performance Rehearsal Space	A space for conducting preparatory music and theatre performances before the official public performance.

Level 1 Title	Level 2 Title	Level 3 Title	Level 4 Title	Definition
			Soundstage	A soundproof, hangar-like space used for the production of theatrical motion pictures and television shows, usually located in a movie studio.
			Performance Hall	A room or theater, often with tiers of seats, which serves as performance venue, such as for classical instrumental music or jazz, or for hearing lectures or presentations. Includes amphitheaters, auditoriums, or concert halls.
			Band Training Space	Space for marching band rehearsal.
		Audience Spaces		Spaces for a group of people who observe a performing art.
			Pre-Function Lobby	A room used for entry from the outside in a building that houses performing arts productions, and in which the audience can gather before showtime and at intermission.
			Audience Seating Space	A space where audience members can sit during a performance.
		Supporting Performance Spaces		Spaces used to provide support to any performance type such as dance, music or theater.
			Projection Booth	Space in a movie theater that houses the projector and other equipment used to show the movie.
			Catwalk	An elevated walkway in a theater or soundstage used to access rigging for lights, curtains, sets, and other items.
			Stage Wings	Areas adjacent to the stage in a theater, where support personnel and players can stand.
			Motion Picture Screen Space	Space for a motion picture screen and associated equipment.
	Display Spaces			Areas for the display of art and other exhibit materials
		Art Gallery		A room, group of rooms, or other space where works of art are placed on display, possibly for sale.
		Exhibit Gallery		A space for a public showing or exhibition of items of interest.
		Sculpture Garden		An outdoor garden dedicated to the presentation of sculpture, usually several permanently-sited works in durable materials in landscaped surroundings.
		Ornamental Garden		A planned space, usually outdoors, set aside for the display, cultivation, and enjoyment of ornamental plants and flowers.
		Observation Deck		A platform situated upon a tall architectural structure or natural feature.

Level 1 Title	Level 2 Title	Level 3 Title	Level 4 Title	Definition
	Creative Spaces			Propose as level one - Space fit-up with features facilitating the production of art and/or the broadcasting, recording, editing or storage of audio visual productions.
		Recording Studio		Space fit-up to facilitate the recording of sounds
		Artist's Studio		Space fit-up to facilitate the development of works of art
		Photo Lab		Space fit-up to facilitate the production and/or repair of film and electronic photography
			Motion Picture Exchange	Space for the distribution of motion picture prints for viewing by military personnel.
		Media Production		Space fit-up with features facilitating the production of televised programming live or recorded.
			Media Production Support	Space supporting media production such as make-up station, dressing room, guest waiting room, wardrobe/prop room
			Sound Lock	Room that provides an acoustical buffer to eliminate the transfer of sound to adjoining space.
		Zen Garden		An enclosed shallow sandpit containing sand, gravel, rocks, and occasionally grass and/or other natural elements, raked and arranged artfully, usually providing a quiet, contemplative setting.
Museum Spaces				
	Museum Gallery			A space in a museum for the exhibition, and educational interpretation of objects having scientific, historical, cultural or artistic value.
Library Spaces				
	Library			Space in which literary, musical, artistic, or reference materials (as books, manuscripts, recordings, or films) are kept for use but not for sale.
		Library Stack		A space used to house arranged collections of literary, musical, artistic, educational or reference materials for use.
Spiritual Spaces				Space designated for the practice of religion or meditation .
	Worship spaces			Spaces for conducting worship activities, such as prayer, religious or spiritual ceremonies or celebration, or meditation.

Level 1 Title	Level 2 Title	Level 3 Title	Level 4 Title	Definition
		Meditation Chapel		A space provided for obtaining a deeper state of relaxation or awareness.
		Altar		A space upon which offerings can be made for religious purposes, or some other sacred place where ceremonies take place.
		Reflection Space		A space for self-observation and contemplation of conscious inner thoughts, desires and sensations.
		Blessing Space		A space for infusion of something with holiness or divine will.
		Chapel		A space used as a place for fellowship and worship for Christians.
		Mihrab		A niche in the wall of a mosque that indicates the direction of the Kaaba in Mecca and hence the direction that Muslims should face when praying.
		Shrine		A holy or sacred place which is dedicated to a specific deity, ancestor, hero, martyr, saint or similar figure of awe and respect, at which they are venerated or worshipped.
		Sanctuary		The consecrated area of a church or temple around its tabernacle or altar.
		Confessional Space		A small, enclosed booth used for the Sacrament of Penance, often called confession, in the Catholic Church.
		Ark		A cabinet used to store a synagogue's Torah scroll.
		Bimah		The elevated area or platform in a Jewish synagogue where the person reading aloud from the Torah stands.
		Tabernacle		A case on the altar of a church that contains the consecrated host and wine for the Eucharist.
		Pulpit		A raised platform in a church, usually enclosed, where the minister or preacher stands to conduct the sermon.
		Choir Loft		A narrow recessed balcony area along an upper floor on the interior of a church, usually marked by a colonnade.
	Ceremonial Spaces			A space for performing a ceremony to change the religious nature or status of a person.
		Marriage Sanctuary		A space for conducting marriage ceremonies.
		Baptistery		The area in a church surrounding the baptismal font.
		Circumcision Space		A space in a religious structure for performing circumcisions.
		Cathedra		The space surrounding the chair or throne of a bishop.

Level 1 Title	Level 2 Title	Level 3 Title	Level 4 Title	Definition
	Procession Spaces			A space for performing a spiritual procession or orderly gathering and movement.
	Death Spaces			Spaces for religious and other proceedings surrounding death, funerals, and interment.
		Crypt		A chambered burial vault used to store the deceased.
		Morgue		A facility for the identification, preparation, and holding of human remains.
			Morgue Compartment	A room used for the storage of human remains awaiting identification, or removal for autopsy, burial, cremation or some other post death ritual.
		Grave Space		A place where a dead body is buried.
Environment ally Controlled Spaces				Space with environments where such variables as humidity, temperature, pressure, sound, contamination are tightly controlled. These Spaces may be part of the research or production processes.
	Anechoic Chamber			Space that is isolated from external sound and electromagnetic radiation sources, using sound proofing and electromagnetic absorptive material to prevent the reflection of wave phenomena (reverberation).
	Hazard Containment			Specialized containment space for hazardous agents such as biological, radiological and chemical hazards.
	Clean Room			Space in which the air quality, temperature and humidity are highly regulated in order to protect sensitive equipment and materials from contamination.
		Clean Room Class 1		The ISO 14644-1 classification describes Clean rooms rated as "Class 1," where there exists no more than 10 particles larger than 0.1 micrometer in any given cubic meter of air;
		Clean Room Class 2		The ISO 14644-1 classification describes Clean rooms rated as "Class 2," where there exists no more than 100 particles larger than 0.1 micrometer in any given cubic meter of air;
		Clean Room Class 3		The ISO 14644-1 classification describes Clean rooms rated as "Class 3," where there exists no more than 1,000 particles larger than 0.1 micrometer in any given cubic meter of air;

Level 1 Title	Level 2 Title	Level 3 Title	Level 4 Title	Definition
		Clean Room Class 4		The ISO 14644-1 classification describes Clean rooms rated as "Class 4," where there exists no more than 10,000 particles larger than 0.1 micrometer in any given cubic meter of air;
		Clean Room Class 5		The ISO 14644-1 classification describes Clean rooms rated as "Class 5," where there exists no more than 100,000 particles larger than 0.1 micrometer in any given cubic meter of air;
		Clean Room Class 6		The ISO 14644-1 classification describes Clean rooms rated as "Class 6," where there exists no more than 1,000,000 particles larger than 0.1 micrometer in any given cubic meter of air;
		Clean Room Class 7		The ISO 14644-1 classification describes Clean rooms rated as "Class 7," where there exists no more than 10,000,000 particles larger than 0.1 micrometer in any given cubic meter of air;
		Clean Room Class 8		The ISO 14644-1 classification describes Clean rooms rated as "Class 8," where there exists no more than 100,000,000 particles larger than 0.1 micrometer in any given cubic meter of air;
		Clean Room Class 9		The ISO 14644-1 classification describes Clean rooms rated as "Class 8," where there exists no more than 1,000,000,000 particles larger than 0.1 micrometer in any given cubic meter of air;
		Clean Room Support Space		Support space for a classified room but not enclosed within a classified room.
	Temperature and Pressure Chamber			Space in which air or other gases can be added or removed to create low/ high air pressure environments. Chambers can also control the thermal environment.
	Data Center			Space designed to accommodate the needs of large quantities of co-located computer equipment.
		Data Center Tier I		Basic Site Structure providing non-redundant capacity and single path distribution systems.
		Data Center Tier II		Redundant Capacity Components with single path distribution systems.
		Data Center Tier III		Concurrently Maintainable Infrastructure which provides redundant capacity and multiple distribution paths.

Level 1 Title	Level 2 Title	Level 3 Title	Level 4 Title	Definition
		Data Center Tier IV		Fault Tolerant Infrastructure providing redundant capacity and multiple distribution paths simultaneously serving dual powered equipment.
		Data Center Support Space		Support space for a Data Center but not enclosed within a Data Center.
	Controlled Space Support			Support space directly involved with environmentally controlled spaces.
	Miscellaneous Environmentally Controlled Spaces			Other Environmentally Controlled space not readily classified in one of the other classes.
		Film Storage Vault		Space fit-up with climate controls and storage equipment to facilitate the preservation of film
		Computer Server Room		Climate controlled space for servers associated with office environments
Healthcare Spaces				Space which is used for services directly related to the health care and medical practice. Most uses are applicable to providing medical care to humans as well as veterinarian services for animals. Size of the space may vary according to the size of the patient however the functions would be consistent as in admissions, diagnostics, surgery etc.
	General Examination Spaces			Spaces used by multiple medical services for routine patient examinations.
		Exam Room		Space used for routine, urgent, and emergent examination (physical inspection of a patient or parts of his body) in order to verify health or diagnose disease or injury. May also be Space used for minor procedures such as injections, wound care, and suturing.
		Exam Room, Airborne Infection Isolation		Space used for examination of patients who are suspected to have or have a condition which could pose an airborne infection threat to other patients.
		Exam Room, Isolation		Space used for examination of patients with suspected contagious diseases.
		Exam Room, OB/Gyn		Space used for gynecological examination of women.
		Exam Room, Pediatric		Space used for examination of patients who conform to institutional criteria as being children, generally 1 year old to 20 years old.

Level 1 Title	Level 2 Title	Level 3 Title	Level 4 Title	Definition
		Exam Room, Protective Environment Isolation		Space used for examination of patients who are suspected to have or have a condition which makes them highly susceptible to infection.
		Exam Room, Podiatry		Space used for the diagnosis and treatment of disorders of the foot, ankle and leg.
		Exam Room, Security		Space used for examination and holding of patients who are under custodial observation due to mental infirmity or judicial restraint.
		Height/Weight Screening Space		Space used for taking measurement of patient height and weight.
		Holding Room, Secured		Space used for placement of patients who need observation for a period of time under police supervision.
	Inpatient Care Spaces			Spaces used for overnight patient care.
		Anteroom, Inpatient Airborne Infection Isolation		Space used for protective segregation of patients who have or are suspected of having contagious diseases to provide access control and environmental separation.
		Anteroom, Inpatient Protective Environment Isolation		Space used for protective segregation of patients whose immune system is compromised to provide access control and environmental separation.
		Anteroom, Inpatient Isolation/Seclusion		Space used in mental health units to provide controlled access to a seclusion room.
		Labor, Delivery, Recovery, Postpartum Room		Space used for the “birthing process” including pre-delivery preparation, delivery, and post delivery recovery. Where the acronym is “LDR” the function does not include the post recovery hospital stay for the mother.
		Medical Information Computer System Room		Space used for equipment and personnel charged with monitoring vital signs telemetry for an intensive care unit setting.
		Newborn Nursery		Space used for observation of newborn infants prior to placement in a newborn nursery or when their condition requires heightened attention or special intervention.
		NICU Nursery		Space used for comprehensive and intensive care for neonates who have low birth weight, are very pre-mature, or who have other developmental and medical complications.

Level 1 Title	Level 2 Title	Level 3 Title	Level 4 Title	Definition
		Nursery Transport Unit Alcove		Space used for parking of specialized infant transport carts including those for transport to other facilities.
		Nursery, Airborne Infection Isolation		Space used for airborne infection isolation (All) segregation of newborns.
		Nursery, Observation		Space used for observation of newborn infants prior to placement in a newborn nursery.
		Nursery, Special Care		Space used for observation of newborn infants prior to placement in a newborn nursery or when their condition requires heightened attention or special intervention.
		Patient Room		Space used for overnight patient care.
			Patient Room, Airborne Infection Isolation	Space used for protective segregation of inpatients who have or are suspected of having contagious diseases.
			Patient Room, Bariatric	Space used for the care of patients who are morbidly obese in an acute care inpatient nursing unit
			Patient Room, Intensive Care	Space used for care of patients whose health status requires highly focused and concentrated medical care services by staff with specialized training and skills.
			Patient Room, Intensive Care, Airborne Infection Isolation	Space used for protective segregation of intensive care patients who have or are suspected of having contagious diseases.
			Patient Room, Intensive Care, Protective Environment Isolation	Space used for protective segregation of intensive care patients whose immune system is compromised.
			Patient Room, Isolation	Space used for restrained isolation of patients for a short duration in a mental health setting
			Patient Room, Monitored	Space used in an inpatient setting where a patient care room must be capable of monitoring of vital signs
			Patient Room, One-Bed	Space used for patient sleeping and care in an inpatient setting for a single patient.
			Patient Room, Protective Environment Isolation	Space used for protective segregation of patients whose immune system is compromised.

Level 1 Title	Level 2 Title	Level 3 Title	Level 4 Title	Definition
			Patient Room, Seclusion	Used for segregation of patients who may pose a risk to themselves or others due to behavioral factors.
			Patient Room, Transitional, One-Bed	Space used for patient sleeping and care in a transitional or apartment setting.
			Patient Room, Two-Bed	Space used for patient sleeping and care in an inpatient setting for two patients.
	Multi-Medical Service Support Spaces			Spaces used by multiple medical services to provide direct support for patient care.
		Clean Linen Storage Room, Healthcare		Space used for storage of clean linen.
		Clean Supply Room, Healthcare		Space used for storage of clean supplies on carts or shelves.
		Clean Utility Room, Healthcare		Space used for the storage of clean supplies and clean linens and their preparation for patient use and for patient care support equipment such as icemakers and refrigerators.
		Consultation Room, Patient		Space used for meetings with patients and family members to discuss health status, learn health history, and provide information.
		Mental Health Interview/Counseling Room		Space used for interviews and counseling with patients in an individual or group format.
		Equipment Storage Room, Healthcare		Space used for storage of equipment such as surgical tables, accessories, carts, etc.
		Medical Records Storage Room		Space used for organized, active filing of physical patient charts, in a specially ordered and controlled environment
		Nurse Workspaces		Spaces used by nurses to perform their work and administer activities.
			Nurse Station	Space used as a central work and management area by nurses, physicians, and technicians. Functions performed include: charting, staff workflow management, monitoring of patient call system, conferring with other patient care staff, and monitoring of patient vital signs.

Level 1 Title	Level 2 Title	Level 3 Title	Level 4 Title	Definition
			Nurse Station/Communication Center	Space used as a central work and management area by nurses, physicians, and technicians. Functions performed include: charting, staff workflow management, monitoring of patient call system, conferring with other patient care staff, and monitoring of patient vital signs.
			Nurse Sub-Station	Space used as a satellite work area for one or two nurses placed where they are in close proximity to patient rooms and (in many cases) have observation windows from the workstation to the patient.
			Nurse Triage Space	Space used to do a rapid assessment of patient acuity in order to determine priority of treatment.
		Soiled Utility Room, Healthcare		Space used for disposal of human waste, bio-hazardous waste, and trash and for temporary storage of soiled linens, and for clean-up of soiled and non-disposable items.
		Soiled Utility/Supply Room, Healthcare		Space used for clean up of equipment Space used for patient care, disposal of trash and biologic waste and storage of soiled linen.
		Mental Health Multipurpose Room w/Control Room		Space used for group therapy and activity sessions in a mental health setting where undetected observation is required.
		Resuscitation Cart Alcove		Space used for emergency resuscitation cart so that it can be near patient care areas.
		Mental Health Quiet Room		Space used as a place where a patient can go to calm down if over stimulated by other activities or events.
	Diagnostic Imaging Spaces			Spaces used for examination of patients by devices which produce an image of tissue, bone, or biophysical structure excluding those used in cardiac diagnostic and interventional services, nuclear medicine services, and radiation therapy services.
		Angiographic Procedure Room		Judges Chambers
		Bone Densitometry Room		Space used for a radiographic technology which measures bone loss, most frequently to diagnose osteoporosis.
		CT Scanning Room		Space used for computerized tomography which creates radiographic images of whole slices of tissue.
		CT Simulator Room		Space used for planning patient treatment which will be preformed using a linear accelerator.

Level 1 Title	Level 2 Title	Level 3 Title	Level 4 Title	Definition
		Cystoscopic Radiology Room		Space used for performing examination of the bladder and urethra using either a flexible or rigid cystoscope. May also involve minor surgical procedures such as removal of stones.
		Head Radiographic Room		Space used for making radiographic images of the head and neck.
		Mammography Room		Space used for low-dose radiographic imaging of the breast.
		Mobile Imaging System Alcove		Space used for parking mobile X-Ray units so that they will be readily accessible, but not obstructing corridors or passageways.
		MRI Scanning Room		Space used for examination of organ structure and condition by use of alternating magnetic fields which create minute but detectable radio frequency waves of different characteristics from different types of tissue.
		MRI System Component Room		Space used for electronic and mechanical components which support a magnetic resonance imaging system.
		PET/CT Scanning Room		Space used for creation of images which superimpose information about the metabolism of the body (positron emission tomography – PET) over the anatomic information about location, shape, and size of various lesions and tissue (computerized tomography – CT).
		PET/CT Simulator Room		Space used for patient treatment planning for PET/CT system.
		Radiographic Chest Room		Space used for special imaging equipment which is capable of rapid patient throughput for routine chest x-rays.
		Radiographic Room		Space used for taking routine radiographic images of the body.
		Radiographic/Fluoroscopic Room		Space used for radiographic imaging equipment which has fluoroscopic capabilities allowing real time examination of the internal organs.
		Radiographic/Tomographic Room		Space used for making tomographic X-Ray images.
		Radiology Computer Systems Room		Space used for Picture Archiving Computer/ Communication System (PACS) associated with imaging systems which produce digital vs. film images.

Level 1 Title	Level 2 Title	Level 3 Title	Level 4 Title	Definition
		Stereotactic Mammography Room		Space used for a radiographic procedure which produces three dimensional images to aid in performing a needle biopsy of the breast.
		Ultrasound Room		Space used in services such as gynecology, cardiology, and ophthalmology for real-time examination of internal organs utilizing high frequency sound waves.
		Ultrasound/Optical Coherence Tomography Room		Space used in Ophthalmology for the location of unseen intraocular foreign bodies, for retinal detachment, and for internal view when the patient's eye lid can not be opened or the patient's eye is blocked by blood or cataracts.
		Whole Body Scanning Room		Space used in nuclear medicine for scanning by use of gamma or scintillation cameras of the whole body for use in diagnosis of a variety of conditions.
	Diagnostic Imaging Support Spaces			Spaces used in support of imaging equipment and personnel.
		Angiographic Control Room		Space used for operator control of angiography equipment
		Angiographic Instrument Room		Space used for preparation, cleaning, and storage of certain equipment used in angiography.
		Angiographic Procedure Control Area		Space used for operator control of an angiographic system and its components.
		Angiographic System Component Room		Space used for electronic and mechanical equipment which supports an angiographic imaging system.
		Silver Collection Area, Diagnostic Imaging		Space used for the collection of and storage of silver from film based radiographic imaging systems.
		Computed Radiology Reader Area		Space used for viewing digital images.
		Computer Image Processing Area, Diagnostic Imaging		Space used for computer equipment which serves digital imaging modalities.
		X-Ray, Digital Image Storage Space		Space used for picture archiving computer system and image quality control.
		CT Control Area		Space used for operator controls for a computerized tomography (CT) imaging system

Level 1 Title	Level 2 Title	Level 3 Title	Level 4 Title	Definition
		CT Power and Equipment Room		Space used to house the electrical power panels and electronic panels, X-ray power supply and components, computer system image processor components, and other peripheral devices for a computerized tomography (CT) imaging system.
		Image Quality Control Room		Space used by technicians to check the quality of images so that retakes can be ordered if needed.
		Image Reading Room		Space used for examination of images produced by radiography, fluoroscopy, nuclear medicine, ultrasound and related technologies.
		X-Ray, Plane Film Storage Space		Space used for plane film storage of patient radiographs in a made for purpose system and controlled environment.
		Mammography Processing Room		Space used for developing films from a mammography imaging system.
		X-Ray Film, Daylight Processing Space		Space used for daylight film processors serving certain types of x-ray equipment.
		MRI Control Room		Space used for operator control console and for operator observation of a magnetic resonance imaging (MRI) procedure.
		MRI Equipment Storage Room		Space used for electronic and mechanical components which support a magnetic resonance imaging system.
		MRI Viewing Room		Space used for technician and physician viewing of images created using a magnetic resonance imaging system.
		PET/CT Control Room		Space used for operator control of a positron emission tomography/computerized tomography scanning system.
		Radiographic Control Room		Space used for operator control of an imaging system. The operator is protected by an emission opaque wall which has a special view window for observation of the patient.
		Radiographic Darkroom		Use for developing plane film images.
		Tele-Radiology/Tele-Medicine Room		Space used for electronic transmission of images to and consultation with providers at outside locations.
		Viewing/Consultation Room, Diagnostic Imaging		Space used for review of diagnostic images and consultation with other providers, family, and patients.
		X-Ray, Mobile C-Arm Alcove		Space used for temporary "parking" of mobile x-ray systems.

Level 1 Title	Level 2 Title	Level 3 Title	Level 4 Title	Definition
	Radiation Diagnostic and Therapy Spaces			Spaces used for examination and treatment of patients by devices which primarily use ionizing radiation or its byproducts (such as thallium). This section is limited to systems used for oncology and nuclear medicine.
		Equipment Calibration Space, Radiation Diagnostic and Therapy		Space used for equipment adjustment as part of a nuclear medicine service.
		Health Physics Laboratory		Space used to calculate safe levels of radiation in various diagnostic and therapeutic procedures.
		Linear Accelerator Component Room, Healthcare		Space used for the linear accelerator device which generates radiation Space used in the patient treatment area.
		Linear Accelerator Entrance Maze, Healthcare		Space used for shielding spaces surrounding the entrance to a linear accelerator room from ionizing radiation.
		Linear Accelerator Room, Healthcare		Space used for external beam radiation treatments for patients with benign or malignant tumors. May also be associated with Intensity Modulated Radiation Therapy (IMRT), Image Guided Radiation Therapy (IGRT), Stereotactic Radiosurgery (SRS), and Stereotactic Body Radio Therapy (SBRT).
		Linear Accelerator Control Room, Healthcare		Space used for equipment which controls the operation of a linear accelerator and its associated safety devices.
		Radioactive Waste Storage Room, Healthcare		Space used for storage of medical radioactive waste.
		Nuclear Medicine Dose Calibration Space		Space used for the calculation and verification of radioactive injectibles Space used in nuclear medicine testing.
		Nuclear Medicine Scanning Room		Space used in nuclear medicine for scanning by use of gamma or scintillation cameras of the whole body or portions of the body for use in diagnosis of a variety of conditions.
		Nuclear Medicine Patient "Hot" Waiting Room		Space used for nuclear medicine patients who have received a radioactive material as part of their treatment or diagnostic routine.

Level 1 Title	Level 2 Title	Level 3 Title	Level 4 Title	Definition
		Patient Dose/Thyroid Uptake Room		Space used for administration of radiopharmaceuticals by injection or intravenously prior to certain imaging procedures.
		Radiation Dosimetry Planning Room		Space used for calculation of radiation dose and duration to be utilized in several different types of radiation therapy systems.
		Radiopharmacy		Space used for the storage, preparation, and dispensing of radiopharmaceuticals.
		Radium Cart Holding Space		Space used for temporary parking of radium transport carts.
		Radiation Therapy, Mold Fabrication Shop		Space used for layout and fabrication of specialized masks which shield portions of a patient's body during radiation therapy treatment.
		Sealed Source Room		Space used for storage and preparation of sealed sources containing radioactive substances used in patient treatment.
	Heart and Lung Diagnostic and Treatment Spaces			Spaces used for cardiac and pulmonary function diagnostic and interventional services.
		Brachytherapy Room		Space used for treatment of in-stent restenosis by radiating the site of the restenosis, or blocking of an artery at a stent. The procedure starts with an angioplasty in which radioactive isotopes are placed at the site of the blockage. After a few minutes the isotopes are removed.
		Cardiac Catheter Instrument Room		Space used for preparation, cleaning and storage of certain catheterization equipment.
		Cardiac Catheter System Component Room		Space used for electronic and mechanical equipment which supports a cardiac catheterization imaging system.
		Cardiac Catheterization Control Room		Space used for operator control of a catheterization imaging system.
		Cardiac Catheterization Laboratory		Space used for a diagnostic and interventional form of fluoroscopy (cardiac angiogram) in which a catheter is inserted through the arm or groin into the heart.

Level 1 Title	Level 2 Title	Level 3 Title	Level 4 Title	Definition
		Cardiac Electrophysiology Room		Space used to record the electrical activity and pathways to the heart in order to diagnose and treat irregular rhythms of the heart. The procedure is similar to that employed for cardiac catheterization.
		Cardiac Testing Room		Space used to conduct a test in which a patient is given an electrocardiogram before and after induction of physical stress. The variation in heart activity between resting and stressed states is evaluated to determine heart condition. This test is closely associated with “thallium stress test” or “cardiolite stress test” in which an “image” of the patient’s heart activity resting and under stress is taken using a nuclear medicine “camera.”
		Echocardiograph Room		Space used to perform an ultrasonic examination of the heart by creating two dimensional or three dimensional real-time images.
		EKG Testing Room		Space used for a non-invasive test which measures electrical activity of the heart to diagnose underlying conditions of the heart. The electrocardiogram test strip is interpreted by looking for characteristic waveform patterns.
		Extended Pulmonary Function Testing Laboratory		Space used to conduct a wide range of tests of the pulmonary system.
		Microvascular Laboratory		Space used for the diagnosis and treatment of the finer blood vessels as opposed to macrovascular laboratory which is concerned with the major vessels. Modalities may include traditional surgery and laser surgery.
		Pacemaker ICD Interrogation Room		Space used for “reading” performance parameters from an implantable cardioverter defibrillator (ICD) or a pacemaker.
		Pacemaker/Holter Monitor Room		Space used to connect a patient to a portable electrocardiogram machine (Holter Monitor) which the patient wears for 24 hours and to read the results of the test.
		Procedure Viewing Area		Space used for observation of invasive cardiology procedures done in a catheterization laboratory.
		Pulmonary Function Testing Laboratory		Space used for a limited battery of tests of patients who are suspected of having lung or airway system condition by pulmonary medicine providers.

Level 1 Title	Level 2 Title	Level 3 Title	Level 4 Title	Definition
		Pulmonary Function Treadmill Room		Space used by the patient for physical exercise during which the patient's pulmonary function and response of gaseous exchange is measured and later analyzed.
		Pulmonary Screening Room		Space used for initial screening of patients by pulmonary medicine providers.
		Respiratory Inhalation Cubicle		Space used for administration of oxygen to ambulatory patients to promote healing.
		Respiratory Therapy Clean-up Room		Space used for decontamination and cleaning of respiratory therapy equipment.
		Spirometry Test Room		Space used for performing spirometry tests as a part of pulmonary medicine service.
		Stress Echocardiograph Room		Space used to perform an echocardiogram (sonogram) during which the heart is placed under physical stress.
		Stress Testing Treadmill Room		Space used to conduct cardiac stress tests in which an electrocardiogram is made while the patient rests and then the patient is stressed by walking on a treadmill. The test is Space used to determine how the heart reacts to exertion and to detect abnormal heart rhythms or ischemia.
		Transesophageal Echocardiography Room		Space used for performing an echocardiograph (a form of sonogram) in which the specialized probe is passed thru the mouth and esophagus of the patient.
	General Diagnostic Procedure and Treatment Spaces			Spaces used by multiple medical services for specific diagnostic and treatment functions which are typically exclusive to those services.
		Allergen Preparation Space		Space used to compound a formulated preparation for oral administration and ingestion containing an immunotherapeutically active amount of at least one allergen.
		Allergy Injection Room		Space used for administration of compounded allergens by injection.
		Allergy Skin Testing		Space used for application of various agents to the bare skin in order to determine source of allergies.

Level 1 Title	Level 2 Title	Level 3 Title	Level 4 Title	Definition
		Antepartum Testing (NST) Room		Space used to determine and control the causes of fetal distress in the antepartum (before labor) period. A variety of tests may used including nonstress test (NST), biophysical profile, and contraction stress test (CST).
		Biofeedback Treatment Control/Office		Space used for technician control of biofeedback treatment and for related administrative work.
		Biofeedback Treatment Room		Space used for development of patient self-awareness through the use of a variety of physiological and vital signs monitors which help the patient apply control to otherwise autonomous functions. The monitoring systems may include electromyography systems, automated sphygmomanometers, neuro-processors and polygraphs.
		Cast and Splint Room		Space used for the placement of casts and splints on patients with orthopedic injury.
		Chemotherapy Treatment Room		Space used for infusion of chemotherapy drugs to one or more patients.
		Dermatology Cryotherapy Space		Space used for removal of a variety of benign and malignant lesions by use of a substance such as liquid nitrogen kept at an extremely low temperature.
		Dermatology Procedure Room		Space used for invasive and non-invasive procedures to ameliorate or correct conditions of the skin, hair, nails, oral cavity, and genitals. May be used for Moh's surgery.
		Dialysis Clean Equipment Preparation Room		Space used for packaging clean dialysis equipment and preparing it for subsequent uses.
		Dialysis Soiled Equipment Processing		Space used for decontamination and cleaning of dialysis equipment prior to its being prepared for subsequent use.
		Dialysis Training Room		Space used for training of dialysis patients and their caregivers in various dialysis techniques
		EEG Exam Room		Space used for the diagnosis of epilepsy, seizures, sleep disorders, and related conditions by recording electrical signals of the brain.
		EEG Instrument and Work Room		Space used for monitoring equipment and technician workspace in a sleep study laboratory
		EEG/Sleep Study Monitoring Room		Space used for conducting sleep studies with an electroencephalograph machine.

Level 1 Title	Level 2 Title	Level 3 Title	Level 4 Title	Definition
		Electromyography Room		Space used to conduct electromyograms (EMG) which detect electrical activity in the muscles. The test is used to diagnose the cause of unexplained muscle weakness including muscular dystrophy, inflammation, pinched nerves, amyotrophic lateral sclerosis (ALS), myasthenia gravis, disc herniation, etc.
		ENT Procedure Room		This room accommodates equipment used for instrumental evaluation and treatment including laryngoscopy, stroboscopy, fiberoptic endoscopy (FEES), surface electromyography (SEMG), cervical auscultation, respiration and swallow coordination assessment, manometry, and digital imaging equipment to view radiology images. This room is also used for tracheo-esophageal puncture voice prosthesis fitting procedures.
		Evoked Potential Response Room		Space used to conduct visual evoked response (VER), visual evoked potential (VEP), auditory brain evoked response (ABER), auditory brain evoked potential (ABEP), somatosensory evoked response (SSER), or somatosensory evoked potential (SSEP) studies for multiple sclerosis, other neurological diseases, or with damaged optic nerves and eyes.
		General Purpose Dirty Treatment Room		Space used for minor medical or surgical treatments which result in excretions of substances which pose a risk of contamination, but which do not require a special level of sterility.
		Immunization Room		Space used for administration of vaccines and other prophylactic substances, generally by injection.
		Infectious Disease Decontamination Shower		Space used to shower patients and/or healthcare workers who may have come in contact with certain toxic substances or particulate radiation.
		Infectious Disease Decontamination Suite		Space used to decontaminate persons who have come in contact with persons who have or may have an infectious disease.
		Life Support Unit Room		Space used for the emergent care of patients who are at immediate risk of loss of life or serious disability such as loss of limb.
		OB/GYN Treatment Room		Space used for the examination and treatment of reproductive organs and conditions of women.

Level 1 Title	Level 2 Title	Level 3 Title	Level 4 Title	Definition
		Patient Observation and Treatment Room		Space used for patients who require a combination of treatment and a period of observation pre or post treatment.
		Pentamidine Treatment Room		Space used for the administration of pentamidine to patients with suppressed immune systems.
		Peritoneal Dialysis Exam Room		Space used for examination of patients with end stage renal disease who may be suited for peritoneal dialysis or for existing peritoneal dialysis patients. Peritoneal dialysis is a process in which the patient's peritoneum (membrane surrounding the abdominal cavity) is Space used as a membrane across which fluids and dissolved matter can be passed in order to exchange them from the blood.
		Peritoneal Dialysis Procedure Room		Space used for the peritoneal dialysis infusion/diffusion process for outpatients with impaired kidney function. Differentiated from hemodialysis. Unless the room is located and configured for overnight stay, the room would not be suited for automated peritoneal dialysis (APD).
		Phototherapy Treatment Room		Space used for a procedure which utilizes a photosensitizing drug applied to the patient which is later exposed to light of a specific wavelength to destroy precancerous and cancerous cells. Also known as photodynamic therapy (PDT), it can be Space used for acne, rosacea, skin cancer, sun damage, cosmetic skin improvement, wrinkles, warts, psoriasis and other skin conditions.
		Renal Dialysis Bed Station, Private		Space used for hemodialysis or peritoneal dialysis of inpatients with impaired kidney function.
		Renal Dialysis Room, Negative Pressure		Space used for hemodialysis of patients with impaired kidney function who also are diagnosed with infectious diseases.
		Renal Dialysis, Chair Station, Cubicle		Space used for hemodialysis of patients with impaired kidney function.
		Renal Dialysis, Water Treatment Room		Space used for purification of water which will be used in the dialysis cleansing treatment
		Sleep Study Room		Space used for conducting a multi-parametric test to diagnose sleep disorders such as sleep apnea. The test utilizes a polysomnograph instrument which records a comprehensive record of biophysical changes that occur during sleep.

Level 1 Title	Level 2 Title	Level 3 Title	Level 4 Title	Definition
		Provider Trainee Observation Area, Healthcare		Space used for observation of patient treatment by medical students and trainees.
		Treatment Cubicle, Healthcare		Space used for and useful for a variety of minor medical and surgical treatments.
		Treatment Room, Healthcare		Space used for various types of treatments, generally of a non-specialty nature where specialized equipment is not required.
		Neuropsychology Testing Laboratory		Space used to study the structure and function of the brain with relationship to specific psychological processes as may occur with traumatic brain injury.
	Eye and Ear Healthcare Spaces			Spaces used for diagnosis and treatment of conditions relating to sight, hearing, balance and related functions.
		Audiology Immittance Room		Space used for tests with certain types of measuring instruments to determine electrical characteristics of the auditory system.
		Audiometric Exam Booth		Space used for audiometric tests in a "soundproof" booth.
		Audiometric Exam Suite		Space used for tests to determine the health status of auditory systems including hearing loss, sensitivity threshold, understanding, and other conditions in a pre-fabricated, "soundproof" testing room with attached control room.
		Audiometric Multi-Exam Suite		Space used for an audiometric suite with two booths and a common workroom.
		Audiology Electrophysiology Exam Room		Space used in audiology for the study of the electrical properties of biological cells and tissues.
		Hearing Aid Testing Laboratory		Space used for testing of hearing aids and for related minor adjustments.
		Electroretinography Room		Space used for visual digitized equipment for conducting electro-oculographic, electroretinographic, and visual evoked cortical potential testing of retina, optic nerve, and visual pathway functioning with analysis.
		ENT Exam Room		Space used for examination of patients with suspected disorders or injuries to the ears, nose, and throat for routine, minor treatments such as cerumen management.

Level 1 Title	Level 2 Title	Level 3 Title	Level 4 Title	Definition
		Exam/Training Room, Low Vision		Space used for examination of low vision patients, storage of low vision devices, and for minor training and education.
		Eye Lane		Space used for routine visual acuity screening generally by using a chart placed a certain distance from the patient who is asked to read successive rows of letters and numbers.
		Laser Treatment Room		Space used for treatment of conditions of the eye with one of several types of laser systems. These include: LASIK, LASEK, LTK and PRK
		Ophthalmology Procedure Room		This room is Space used for assessment of eye health, acuity, and presence of disease and for minor treatments. It includes equipment such as a phropter for measuring acuity and a slit lamp Space used in conjunction with a biomicroscope for examination of the eye exterior and interior structure. Some conditions of the eye may be treated with minor surgical or with medical procedures in the treatment room.
		Ophthalmology/Optomety Exam Room		Space used for the examination of eyes and related tissue to determine status of health (including visual acuity) and presence of diseases or injured tissue. Methods of examination include direct visual observation and use of equipment such as slit lamps, retinoscopes, and phoropters.
		Photography Room, Ophthalmology/Optomety		Space used for a special camera attached to a low power microscope (fundus camera or retinal camera) to take pictures of the interior lining of the eyeball and related structures including the retina, optic disc, macula, and posterior pole.
		PRK/LASIK Treatment Room		Space used for two types of laser surgery on the eye. Photorefractive keratectomy (PRK) is Space used to reshape the surface of the cornea. Laser in situ keratomileusis (LASIK) uses a laser underneath the corneal flap to reshape the cornea. It uses an excimer laser specially designed for the procedure. Both techniques treat refractive errors such as myopia, hyperopia, and astigmatism.
		Sinusoidal Vertical Axis Rotational Rest Room		Space used for a specific test which is generally part of a battery of tests to diagnose certain conditions of the vestibular and ocular systems.

Level 1 Title	Level 2 Title	Level 3 Title	Level 4 Title	Definition
		Tilt Table Testing Room		Space used to determine the cause of fainting. The patient is placed on a table which is tilted upward in increments while the vital signs (blood pressure, pulse, other symptoms) are being monitored.
		Training Room, Low Vision, Polytrauma		Space used to provide vision rehabilitation care. Patient education and eye care counseling sessions are conducted so that patients can learn how to use prescribed low vision and other aids.
		Ultrasound/Optical Coherence Tomography Room		Space used in Ophthalmology for the location of unseen intraocular foreign bodies, for retinal detachment, and for internal view when the patient's eye lid can not be opened or the patient's eye is blocked by blood or cataracts.
		Vestibulography Room		Space used for examination of the vestibular system which controls balance and sense of spatial orientation. It provides dominant input about equilibrioception and movement and for performing electronystagmography (ENG) or videonystagmography (VNG) for patients with balance or vestibular disorder.
		Vision/Hearing Screening Room		Space used for initial vision and hearing screening and preparation of patients for further diagnostic tests
		Vision Screening Room		Space used to assist in the performance of preliminary testing and preparation of the patient's profile with the supervision of the optometrist or ophthalmologist.
		Vision Testing Station		Space used for initial screening and preparation of patients by ophthalmology technicians under the supervision of providers.
		Visual Fields Room		Space used to test, evaluate and monitor the visual fields (side vision) of a patient who may or may not be ambulant.
		Eye, Contact Lens Fitting/Dispensing Space		Space used for fitting of prescription contact lenses and for related patient education.
		Eyeglass Fitting and Dispensing Space		Space used for fitting of prescription eyeglasses.
	Endoscopy / Gastroenterology Spaces			Spaces used for examinations and treatments of the esophagus, lungs, stomach, digestive and associated anatomical structures using endoscopes and related systems.

Level 1 Title	Level 2 Title	Level 3 Title	Level 4 Title	Definition
		Bronchoscopy Equipment Preparation Room		Space used for decontamination, cleaning, packaging, and storing equipment Space used to perform bronchoscopies.
		Bronchoscopy Procedure Room		Space used for examination of patient's lungs, airways, voice box, vocal cord, and trachea by placement of a flexible fiberoptic bronchoscope into the windpipe which displays the images on a monitor or at the end of the instrument. The procedure often involves "conscious sedation."
		Endoscope Clean-up, Sterilization, and Storage Room		Space used for cleaning and sanitizing or sterilizing medical endoscopes and related or similar devices
		Endoscopy Room		Space used for examination of the upper and lower gastrointestinal tract by use of a thin, flexible tube or wireless capsule (endoscope) which transmits real time images to a display monitor. The device may also allow biopsy and electrocautery.
		Gastroenterology Laboratory		Space used for gastric analysis studies (to analyze stomach contents) and esophageal manometry (study to determine swallowing disorders).
		Proctoscopy/Sigmoidoscopy Room		Space used for examination of the rectum and lower colon by use of a flexible tube (sigmoidoscope) to determine the cause of rectal bleeding and diarrhea and as screening examination for conditions of the colon.
		Urodynamics Treatment Room		Space used for various tests which provide information about the bladder. Most of the tests do not require sophisticated equipment, but video urodynamics utilizes radiographic or sonographic systems. May also serve as preparation room for other tests and procedures relating to bladder function and voiding disorders.
	Surgical Spaces			Spaces used for surgical procedures and for direct support of surgical functions.
		Anesthesia Workroom and Equipment Storage		Space used for storage, minor operator maintenance, and preparation of anesthesia machines and associated equipment.
		Cardiac Operating Room		Space used for cardiac and cardiovascular surgical procedures, in particular those in which a heart/lung machine is utilized.

Level 1 Title	Level 2 Title	Level 3 Title	Level 4 Title	Definition
		Cardiac Pump Room		Space used for equipment associated with heart/lung machines utilized in open heart surgery.
		Cesarean Birth Room		Space used for the surgical procedure of delivery of infants via Cesarean Section.
		Cystoscopy Room		Space used for surgery of the excretory organs.
		Equipment Storage Room, Surgical		Space used for storage of equipment such as OR tables, accessories, carts, etc.
		Frozen Section Laboratory		Space used for rapid preparation, sectioning and microscopic examination of specimens obtained during surgery.
		General Operating Room		Space used for non-specialized surgical procedures.
		Nerve Block Induction Room		Space used for the injection of local anesthetic for temporary reduction of pain. The process may include the use of ultrasound, fluoroscopy, or CT.
		Neurosurgery Operating Room		Space used for surgery of the brain and central and peripheral nervous system
		Orthopedic Operating Room		Space used for surgery of the skeletal system, muscles, tendons, ligaments and associated tissue.
		Patient Holding Area, Surgical		Space used for temporary holding of pre-surgical patients in the surgical department. Additional uses may include anesthesiologist interview of patient, preparation of surgical site, and inception of sedation or anesthesia agents.
		Post anesthesia Recovery Cubicle		Space used for the recovery of a patient who has had general anesthesia during a surgical procedure
		Postanesthesia Recovery Isolation Room		Space used for post anesthesia recovery of patients who may have an infectious disease.
		Postoperative Recovery Lounge		Space used for step down or Phase II recovery of surgical patients, particularly outpatients who will be discharged to home subsequent to their discharge from the postanesthesia recovery room.
		Preparation/Recovery Spaces, Surgical		Space used for preoperative patient preparation and postoperative recovery.
			Preparation/Recovery Cubicle, Surgical	Space used for preoperative patient preparation and postoperative recovery in an ambulatory or outpatient surgery setting

Level 1 Title	Level 2 Title	Level 3 Title	Level 4 Title	Definition
			Preparation/Recovery Room, Surgical	Space used for preparation and holding of patients prior to surgery and for recovery after surgery, generally in an outpatient or ambulatory care setting.
		Procedure/Minor Operating Room		Space used for a class of surgical procedure which generally does not require general anesthesia and which are generally performed on ambulatory patients. Examples include: incision and drainage of abscesses and cysts, evacuation of hemorrhoids, excision of small skin lesions, small skin grafts, debridement of wounds, and suture removal.
		Scrub/Gowning Area		Space used by surgical staff for scrubbing of hands and lower arms during the process of preparing for surgery and for donning sterile gowns before entering an operating room.
		Sub-Sterile Room		Space used to support one or more operating rooms by providing space for flash sterilization of instruments, storage of warmed blankets, and other accessory functions.
		Operating Room, Sterile Storage		Space used for storage of supplies which must be maintained in a sterile state.
		Surgical Laser Treatment Room		Space used for surgical techniques which employ various types of lasers. In addition to eye surgery, surgical lasers are used in dermatological procedures, vascular surgery, neurosurgery, and spinal orthopedic procedures. Procedures which require general anesthesia are performed in an operating room.
		Recovery Room, Surgical		Space used for the recovery of patients who have been administered general anesthesia.
		Surgical Suite, Workroom and Supply Space		Space used for cleaning and sterilization of surgical instruments, preparation of sterile surgical instrument packs, and storage of surgical supplies in a veterinary research service setting.
	Clinical Laboratory Spaces			Spaces used for testing of human biological specimens to determine health status, to diagnose disease, and to prepare blood and serum for patient use.
		Automated Clinical Laboratory		Space used to house a central area in the clinical laboratory that performs the high-volume, automated testing of hematology, coagulation, chemistry, and urinalysis specimens.

Level 1 Title	Level 2 Title	Level 3 Title	Level 4 Title	Definition
		Bioassay - Radioimmunoassay Room		Space used for a technique which employs a radiolabeled antigen and other substances to measure the level of a specific antigen in the serum of a patient. The test is employed to study conditions of the immune system. The test procedure is extremely sensitive, but it requires special equipment and hazardous substances.
		Blood Gas Laboratory		Space used for testing equipment which determines the concentrations of certain gases in the bloodstream. Function is associated with intensive inpatient care, cardiovascular care, and pulmonary medicine.
		Blood Hemotherapeutics Room		Space used for the collection of special blood components (white blood cells, platelets, etc.) from patients; and the therapeutic removal of plasma (plasmapheresis) or blood cells (cytophoresis).
		Bone Dissection Laboratory		Space used for dissection and analysis of bones and bone specimens in a clinical pathology or autopsy service setting.
		Clinical Chemistry Laboratory		Space used for chemistry, hematology, and urinalysis functions in a hospital, ambulatory care, or outpatient facility.
		Clinical Microbiology Laboratory		Space used for manual and automated microbiology tests and systems.
		Cytology Laboratory		Space used for the examination of cells to determine the presence of disease, cancer or other conditions especially gynecological specimens.
		Cytology Screening and Histology Space		Space used to study cells for morphologic abnormalities indicative of disease.
		Dermatology Laboratory		Space used for analysis of specimens obtained during dermatological procedures in a clinic or outpatient setting.
		Electron Microscope Suite		A group of rooms Space used to house an electron microscope and its related components. Electron microscopes use a beam of electrons to achieve magnifications (up to 2 million times) which is much greater than that possible with a light microscope. Electron microscopes have a variety of scientific and industrial applications. In science these include: cryobiology, electron tomography, cellular tomography, toxicology, pharmaceutical quality control, and virology.
		Electron Microscope System Room		Space used for the principal components of an electron microscope

Level 1 Title	Level 2 Title	Level 3 Title	Level 4 Title	Definition
		Entomology Laboratory		Space used for the examination of insects which may carry disease and/or which may be vectors that carry disease to humans.
		Flow Cytometer Space		Space used for a test which counts and examines microscopic particles, such as cells. It is Space used for diagnosis of certain health disorders such as blood cancers.
		Fluorescence Microscope Room		Space used for fluorescence microscope work. One component of the specimen is labeled with a fluorescent material and then illuminated with a light of a specific wavelength to reveal its properties.
		General Clinical Laboratory Area		Space used for testing of specimens or other substances to determine their chemical and biological properties for the purposes of research and patient care
		Hematology Laboratory, Coagulation		Space used to tests to study those properties of blood specimens relating to coagulation, a process through which blood loss is limited after injury to the blood carrying structure.
		Hematology Laboratory, Routine		Space used for the study of blood and blood forming organs for the diagnosis of disease or chronic health problems.
		Histology Laboratory		Space used for the processing of tissue specimens through automated processors, embedding the specimens in paraffin blocks, sectioning the specimens and staining them for examination by pathologists.
		Immunopathology Laboratory		Space used for the study of immune responses related to disease.
		Microbiology Biosafety Laboratory		Space used for testing of biologically hazardous specimens.
		Microbiology Mycology Laboratory		Space used for identification and testing of fungi and susceptibility testing for anti-fungal drugs.
		Microbiology Mycobacteriology Laboratory		Space used for TB culture and susceptibility testing of microorganisms.
		Mohs Laboratory		Space used for analysis of specimens/biopsies obtained during dermatological procedures.
		Mycology Laboratory		Space used for the study of fungi and their relationship with health conditions.

Level 1 Title	Level 2 Title	Level 3 Title	Level 4 Title	Definition
		Nephrology Renal Study Space		Space used by nephrologists for study of renal condition and mal-performance.
		Renal Studies Laboratory		Space used for the investigation of diseases and conditions of the kidneys and related systems.
		Special Chemistry Laboratory		Space used for special and unique diagnostic procedures such as chromatography, EMIT and/or manual spectrophotometry, fluorometry, etc. to perform therapeutic drug monitoring, toxicology, endocrinology, heavy metal, nutrition and metabolism studies.
		Urine Testing Alcove		Space used in conjunction with and adjacent to a specimen collection toilet for routine testing of urine specimens.
		Urinalysis Laboratory		Space used for the biochemical analysis and microscopic examination of urine and feces for the detection of abnormalities or disease.
		Urology Laboratory		Space used to examine urine, blood, and secretions of the genitourinary tract in order to assess the health conditions of the genitourinary system and, where indicated, develop a diagnosis and plan of treatment
		Medical Autopsy Room		Space used for forensic examination of human remains.
	Clinical Laboratory Support Spaces			Spaces used exclusively in support of clinical laboratory operations.
		Blood Bank Donor Station		Space used for donating blood in an organized blood banking program.
		Blood Bank Preparation Rom		Space used for red cell packing, red cell washing, freezing/rejuvenating, thawing and deglycerolizing, freezing of frozen plasma, preparation of cryoprecipitate, thawing of cryoprecipitate, pooling of cryoprecipitate, platelet and granulocyte concentrates from single units, and pooling platelets.
		Blood Bank Blood Product Storage Space		Space used to store, type, and cross match blood.
		Blood Bank Storage and Transfusion Room		Space used to store, type, cross match, and transfuse blood.

Level 1 Title	Level 2 Title	Level 3 Title	Level 4 Title	Definition
		Blood Specimen Collection Room		Space used for phlebotomy, drawing of blood specimens from patients.
		Cell Bank Freezer, Ultra Low		Space used for the storage of cell stocks Space used in research to inhibit deterioration of the functional and biological characteristics of the cells.
		Electron Microscope Automated Data Processing Room		Space used for data processing equipment utilized by technicians in the analysis of results obtained during examination of specimens.
		Electron Microscope Cutting Room		Space used for sectioning prepared specimens prior to examination by an electron microscope.
		Electron Microscope Dark Room		Space used for the processing of films made during examination of specimens using an electron microscope.
		Electron Microscope Developing, Printing and Enlarging Room		Space used to develop and process films and prints made during electron microscope examination.
		Electron Microscope Finishing Room		Space used for final work in preparing prints for use.
		Electron Microscope Preparation Room		Space used for preparing specimens for examination under an electron microscope. This may involve using chemical compounds, dehydration, or cryofixation. Specimens are then embedded in a stabilizing material which allows them to be sectioned.
		Glassware Washing and Decontamination Room, Clinical Laboratory		Space used for gross decontamination, cleaning, washing and sterilizing various types of glassware Space used in clinical and research laboratories
		Glassware Washing Room, Clinical Laboratory		Space used for gross decontamination, cleaning, washing and sterilizing various types of glassware Space used in clinical and research laboratories
		Slides and Blocks Storage Room, Clinical Laboratory		Space used to store slides, as a matter of record keeping, for a set period of time after they have been examined by a pathologist.
		Sterilization and Solution Preparation Room, Clinical Laboratory		Space used for sterilizing solutions and compounds Space used during the analysis of specimens in a laboratory.

Level 1 Title	Level 2 Title	Level 3 Title	Level 4 Title	Definition
		Tissue Storage Area, Clinical Laboratory		Space used for storage of tissues which may be in a variety of forms such as paraffin blocks or in preservative fluid filled sealed containers.
		Microbiology Media Preparation Laboratory		Space used to prepare media for culturing in support of microbiology.
		Specimen Accessioning, Processing and Distribution Room		Space used as a general receiving area for specimens and requests.
		Laboratory, Water		Space used to treat water which has acquired certain chemicals during its used in sterilizing surgical instruments.
	Pharmacy Spaces			Spaces used to receive, prepare, compound, test and examine pharmaceuticals and to dispense them as requested for patient care.
		Chemotherapy Agent Medication Preparation Room		Space used for preparation of compounds and IV admixtures to be administered to patients with cancer.
		Compound Sterile Preparation Space - High Risk		Space used for compounding of medications which require a sterile environment.
		Compound Sterile Preparation Space - Low Risk		Space used for compounding of medications which require a sterile environment.
		Compounding Area		Space used for pharmacist preparation of medications.
		Dialysate Preparation Room		Space used for the preparation of dialysate prior to dialysis patient treatment.
		IV Admixture Anteroom		Space used for gowning and hand sanitizing prior to entry into an IV Admixture Room.
		IV Admixture Room		Space used for preparation of IV admixtures in a sterile environment.
		Medication Preparation Room		Space used for the preparation of prescribed medicines for administration to a patient.
		Methadone Dispensing Station		Space used for dispensing methadone to heroin addicts.
		Oncology Drug Preparation Area		Space used for preparation of drugs Space used in chemotherapy, in particular those administered intravenously.

Level 1 Title	Level 2 Title	Level 3 Title	Level 4 Title	Definition
		Pharmacy		Space used for compounding, packaging, dispensing and managing pharmaceuticals.
		Pharmacy, Dispensing Space		Space used in a pharmacy for dispensing medications to outpatients or for patient care units.
		Pharmacy Manufacturing & Prepack Space		Space used for compounding, packaging, and sorting of medications for dispensing and administration to patients.
		Prescription Receiving Station		Space used by a pharmacist or pharmacy technician for receiving prescriptions.
		Pharmacy, Bulk, Breakdown and Verification Area		Space used for storage of pharmaceuticals in a pharmacy in bulk packaging format and for cross checking delivery records.
		Pharmacy, Controlled Substances and Secured Dispensing		Space used in a pharmacy for storage of controlled pharmaceuticals and related controlled pharmacy supplies. This is the vault and dispensing area for drugs identified by DEA requiring separation from other medications due to high abuse potential.
	Medical Services Logistic Spaces			Spaces used for cleaning, sterilizing, packaging, stocking and distributing various types of supplies in a health care setting. Includes spaces used for receiving and holding soiled linens and receiving and distributing clean linens.
		Automatic Cart Wash Area, Healthcare		Space used for mechanical system which washes various types of carts Space used for surgical cases, supply delivery, and/or linen handling.
		BSL3 Infectious Disease Suite, Autoclave Room		Space used for sterilizing equipment and supplies within a biosafety level 3 infectious disease suite .
		BSL3 Suite, Autoclave Room		Space used for sterilizing equipment and supplies within a biosafety level 3 suite.
		Cart Assembly/Queue Area, Healthcare		Space used in a surgical clean core concept for “stacking” of surgical case carts in the clean core or designated area of central sterile supply.
		Clean Cart Holding Area, Healthcare		Use for clean carts containing supplies or linens.
		Medical Material Cart Restocking Area		Space used for stocking of unit supply carts in a hospital supply cart distribution system.

Level 1 Title	Level 2 Title	Level 3 Title	Level 4 Title	Definition
		Clean Linen Preparation and Storage Area, Healthcare		Space used for preparation and stocking of linens for distribution to patient service units.
		Clean Supply Preparation and Assembly Area, Healthcare		Space used for preparation and assembly of supplies for distribution to patient service units.
		Clean Supply Preparation Area, Healthcare		Space used for equipment and supply packaging and preparation for future use where storage is provided elsewhere.
		Equipment Processing and Clean Storage Room, Healthcare		Space used for the processing of equipment such as cystoscopes, preparing them for future use, and clean storage
		Ethylene Oxide Gas Sterilizer Room		Space used to house an ethylene oxide gas sterilizer Space used for terminal sterilization of certain types of medical and surgical equipment.
		Instrument Sterilization Room		Space used for post-decontamination, cleaning, washing and sterilizing various types of medical equipment of the types generally Space used for invasive procedures.
		Central Sterile, Receiving and Decontamination		Space used for reception and gross decontamination of supplies and equipment used in various surgical and other invasive procedures.
		Manual Cart Wash Area, Healthcare		Space used for washing soiled carts such as food carts, supply carts or surgical case carts.
		Soiled Cart Holding Area, Healthcare		Space used for temporary holding (parking) of supply or case carts which require washing or disinfection prior to reuse.
		Soiled Cart Receiving Area, Healthcare		Space used for temporary holding (parking) of supply or case carts which require washing or disinfection prior to reuse.
		Soiled Instrument and Equipment Receiving and Decontamination Room, Healthcare		Space used for gross decontamination of surgical instruments and equipment prior to repackaging and/or sterilization.

Level 1 Title	Level 2 Title	Level 3 Title	Level 4 Title	Definition
		Sterile Supply Preparation and Assembly Area, Healthcare		Space used for packaging, preparation, assembly and storage of surgical and other procedure packs where a sterile environment is required.
		Biomedical Electronic Repair		Space used for repair of electrical and electronic components of medical instruments and equipment.
	Rehabilitation Spaces			Spaces used for physical and occupational/vocational rehabilitation, for designing, and for manufacturing dispensing and fitting orthotic and prosthetic appliances.
		Amputee Training Area		Space used in physical therapy and rehabilitation medicine for training and exercises for persons who have suffered limb loss.
		Brace Shop Fitting Shop		Space used to apply casts, fit, construct, and adjust artificial facial or body appliances that need color coordination with adjacent body tones.
		Brace Shop , Adjustment/Modification Area		Space used for adjustments and changes which must be made to prosthetics during the process of fitting to a patient.
		Brace Shop Welding Area		Space used for fabrication of prosthetic braces where welding is required.
		Computer Activities Room, Rehabilitation		Space used for rehabilitative therapy related to the use of computers.
		Prosthesis Design and Manufacturing Room, Rehabilitation		Space used for computerized equipment to scan and measure residual limbs of patients with amputation and for a computerized lathe for fabrication.
		Dynamic Alignment Room		Space used for a particular system for fitting and adjustment of prostheses for lower leg amputee
		Therapeutic Exercise Spaces		Spaces used for various exercise and related therapeutic modalities intended to restore or improve physical function.
			Therapeutic Exercise Area	Space used for individual and group exercise and for exercise classes and instruction.
			Exercise/Therapy Gymnasium	Space used for group and individual therapy including various types of exercises ranging from use of free weights to machines such as treadmills and exercise bikes.
			Individual Therapeutic Exercise Area	Space used for individual physical training and exercise as a part of a physical rehabilitation program.

Level 1 Title	Level 2 Title	Level 3 Title	Level 4 Title	Definition
			Treatment/Exercise Area	Space used for physical therapy gymnasium to accommodate a wide variety of exercise procedures and training functions.
		Eye Fitting Studio		Space used to display, fit, match and color coordinate artificial eyes.
		Facial/Body Fitting Studio		Space used to fit custom made prosthetics and orthotics to a patient.
		Fitting Room, Custom Fabrication		Space used for examination of patients prior to and during fabrication of prosthetic and orthotic devices.
		Fitting Room, Soft Goods Fabrication		Space used for fitting of various prosthetic and orthotic devices and for follow-up examination.
		Gait Lane		Space used in physical therapy treatment of problems of ambulation and in training and exercise for patients with lower extremity prosthetic devices. The gait lane is focSpace used on persons with lower limb or trunk conditions sometime associated with neurological or orthopedic impairment. The parallel bar area is focSpace used on restoring basic ambulation skills.
		Gait Study Track		Space used for diagnosis and treatment of ambulation disorders where equipment is Space used in obtaining and analyzing patient movement.
		Hearing Aid Fabrication and Modification Room		Space used for construction, adjustment and maintenance of hearing aids and bioelectric implants
		Hubbard Tank - Full Immersion		Space used for a specialized treatment tank in which pressurized and/or heated streams of water are circulated around the body of the patient
		Hubbard Tank - Partial Immersion		Space used for a specialized treatment tank in which pressurized and/or heated streams of water are circulated around an immersed portions of the body of a patient
		Hydrotherapy Area		Space used for treatments in which the patient or a portion of his body is immersed in a tank in which the water is heated and circulated by jets or other devices.
		Neurophysiology Rehabilitation Room		Space used for treatment of problems relating to nervous system functioning. May include techniques and procedures also Space used for vocational therapy
		Occupational Therapy Room		Space used for development of occupational (work) related skills and attitudes.

Level 1 Title	Level 2 Title	Level 3 Title	Level 4 Title	Definition
		Occupational Therapy, Daily Living Skills Training and Evaluation Room		Space used to train patients in adaptive behavior needed to perform routine living skills. Generally arranged to include fixed and movable items which a person would encounter in daily living.
		Pediatric Developmental Therapy Space		Space used for treatment of children who suffer from chronic or acute conditions which have impaired their physical and/or neurological development. May include occupational therapy, speech therapy, and physical therapy.
		Physical Therapy/Kinesiology Therapy Room		Space used for physical therapy treatment and gymnasium to accommodate a wide variety of functions including prosthetic and orthotic training.
		Posturography Exam Room		Space used for examination of patients with a battery of tests to evaluate balance function using a series of tasks to simulate situations encountered in daily life.
		Prosthetic and Orthotic Dust Room		Space used for fabrication equipment which generates quantities of dust.
		Prosthetic and Orthotic Fume Room		Space used for fabrication processes which generate toxic or unpleasant fumes.
		Prosthetic and Orthotic Work Station		Space used for prosthetic and orthotic technician workspace, bench space, and power equipment.
		Prosthetic and Orthotic, Maintenance Support Room		Space used for repairs and routine maintenance of prosthetic and orthotic devices.
		Rehabilitation Therapy Gym		Space used for exercise and treatment interventions related to physical therapy.
		Speech Pathology Individual Therapy Room		Space used for speech therapy for a single patient.
		Speech Therapist, Exam and Treatment Space		Space used for individual examination and treatment of speech deficits by a speech therapist.
		Therapeutic Pool		Space used for therapeutic swimming and related activities for individuals or groups.
		Wheelchair Repair Workspace		Space used for the repair of wheelchairs.

Level 1 Title	Level 2 Title	Level 3 Title	Level 4 Title	Definition
		Whirlpool		Space used for a specialized treatment tank in which pressurized and/or heated water is circulated around the arm or leg of a patient.
		Rehabilitation Living Skills Training Apartment		Space used in a rehabilitation program to train and evaluate patients, shortly before discharge, in a realistic living setting.
	Dental Spaces			Spaces used for dental hygiene care, routine dentistry, and for design, fabrication, application and adjustment of dental and maxillo-facial appliances for corrective and reconstructive purposes.
		Dental CS Suite		Spaces which constitute a specialized dental support and sterilization function.
		Dental Hygiene and Operatory Room		Space used for dental hygiene and routine treatments such as fillings, crowns, application of sealants and some cosmetic procedures.
		Dental Hygiene Room		Space used for routine dental hygiene.
		Dental Porcelain Room		Space used for the fabrication of porcelain dental prosthetics.
		Dental Prosthetics Laboratory		Space used for the fabrication and adjustment of dental prosthetics.
		Dental Screening Room		Space used for routine screening examination (triage) to determine health of the teeth, gums and surrounding tissue.
		Dental Self Preparation Area		Space used by patients to prepare for dental services.
		Dental Treatment Room, Mini Laboratory		Space used for routine dental office procedures such as making impressions, crowns, and bridges to support general dentistry.
		Dental Treatment Room		Operatory, General Treatment or Operatory, Dental Hygiene Space used for routine cleaning and examination of teeth, gums and surrounding tissue and for treatments not requiring general anesthesia such as fillings crowns, application of sealants and some cosmetic procedures.
		Dental Treatment Room, Conscious Sedation Support		Space used for preparation of anesthetizing and sedating agents which produce a state of relaxation and/or pain relief to be given to patients undergoing dental prosthetic/reconstructive surgery

Level 1 Title	Level 2 Title	Level 3 Title	Level 4 Title	Definition
		Dental Treatment Room, Endodontics		Space used for the diagnosis and treatment of conditions relating to the tooth pulp and the tissues surrounding the root of the tooth.
		Dental Treatment Room, Orthodontics		Space used for the design, application and control of corrective appliances to move teeth or adjust underlying bone to bring teeth, lips, and jaws into proper alignment and achieve facial balance.
		Dental Treatment Room, Pediatrics		Space used for examination, diagnosis and treatment of teeth, gums, and supporting structures of pediatric patients.
		Dental Treatment Room, Periodontics		Space used for the prevention, diagnosis, and treatment of patients with diseases affecting the gums and supporting structures of the teeth. Includes placement and maintenance of dental implants.
		Dental Treatment Room, Prosthodontics		Space used for the examination and treatment of patients who may require special prosthetics for missing or deficient teeth or oral and maxillo-facial tissues.
		Dental X-Ray Room		Space used to make intra-oral (several teeth) and cephalometric (entire head) x-rays for use in diagnosis and treatment of dental and maxillo-facial conditions.
		Instrument Preparation and Sterilization Room		Space used for cleaning, sterilizing and packing dental instruments and supplies.
		Maxillo-Facial Laboratory		Space used for prosthetic treatment of patients with abnormal conditions of the face and oral structures.
		Maxillo-Facial Treatment Room		Space used for prosthetic treatment of patients with abnormal conditions of the face and oral structures.
		Oral Pathology Laboratory		Space used for the study of tissue from oral and facial areas
		Oral Surgery Residency Room		Space used for surgery of the mouth and jaw particularly where anesthesia or heavy sedation is Space used in services which include a residency program.
		Oral Surgery Room		Space used for surgery of the mouth and jaw particularly where anesthesia or heavy sedation is Space used.
		Panoramic Dental X-Ray Room		Space used for making panoramic x-rays for use in diagnosis and treatment of dental conditions.
		Dental X-Ray Support Room		Space used for support of dental x-ray systems.

Level 1 Title	Level 2 Title	Level 3 Title	Level 4 Title	Definition
	Medical Research and Development Spaces			Spaces used for basic research on the nature and prevention of disease and injury. May involve use of animals and/or highly toxic or infectious matter which must be contained in special rooms or suites of rooms.
		Research Animal Recovery Area		Space used in a veterinary research area for recovery of animals who have had surgery.
		Barrier Suite, Procedure Laboratory		Space used for the control of microbial agents Space used in animal research to keep to keep harmful agents away from the area.
		Biomedical Research BSL3 Suite Tissue Culture Room		Space used for preparation, culturing, and examination of tissue research specimens in a clean room environment.
		Biomedical Research Tissue Culture Room		Space used for preparation, culturing, and examination of research specimens.
		Laboratory, Research, Biochemistry		Space used for biochemistry research related to human health and treatment of injury and disease.
		Biosafety Level 3 Laboratory		A group of spaces which are Space used for procedures which are part of animal research and which require a high level of environmental containment.
		BSL3 Infectious Disease Suite, Procedure Laboratory		Space used for the preparation and administration of infectious diseases to animal subjects in a research setting where a high degree of risk is present. The purpose is to keep agents in the suite from being transmitted outside the suite, i.e. containment.
		BSL3 Procedure Room		Space used for procedures which are part of animal research and which require a high level of environmental containment. The Department of Homeland Security defines the BSL-3 level of containment as follows: "BSL-3: Microorganisms present in the United States, and foreign and emerging agents that may cause serious consequences in livestock but are not harmful to human beings because of available protective measures."
		Environmental Suite Infectious Disease Procedure Laboratory		Space used for performing diagnostic laboratory procedures such as routine bacterial cultures, serology, hematology, clinical chemistry, and parasitological examinations in a veterinary research facility.

Level 1 Title	Level 2 Title	Level 3 Title	Level 4 Title	Definition
		Research Infectious Disease Animal Holding Area		Space used for temporary segregation in a research facility of animals who have or are suspected of having a contagious disease.
		Research Veterinary Radiography Control Room		Space used in a research facility for the operator controls for a veterinary radiographic imaging system for animals.
		Research and Development Machine Shop		Space used for fabrication of mechanical and electro-mechanical devices to be Space used in various research programs.
		Research Veterinary Radiography Procedure Room		Space in a research facility used for veterinary radiographic imaging for animals
		Research Diagnostic Laboratory		Space used for performing routine diagnostic laboratory procedures such as bacterial cultures, serology, hematology, clinical chemistry, and parasitological examinations in a research setting where high level environmental control is not required.
		Research NMR Room		Space used to house a 400 megahertz super shielded instrument in a research setting.
		Research Procedure Laboratory		Space used for multi-user performance of minor surgical procedures, specimen collection, and monitoring procedures in a research setting.
		Research Veterinary Surgical Suite, Animal Preparation Room		Space used for the preparation of animals prior to surgery in a research facility.
		Research Veterinary BSL3 Infectious Disease Suite Holding Room		Space used for temporary placement of research animals in a biosafety level 3 suite.
		Research Veterinary Barrier Suite Holding Room		Space in a research facility used where immune-suppressed animals are present to prevent entrance of harmful agents.
		Research Veterinary Chemical/Radioisotope Suite Holding Room		Space used to temporarily house animals where animal experiments involve the administration of harmful chemical or radioactive agents.

Level 1 Title	Level 2 Title	Level 3 Title	Level 4 Title	Definition
		Research Veterinary Environmental Suite Holding Room		Space used to accommodate animals Space used in research requiring rigid control of various environmental factors such as light, temperature, humidity, sound and air movement.
		Research Veterinary Quarantine Holding Room		Space in a research facility used for segregation of animals who may have contagious diseases or infections.
		Research Veterinary Surgery Room		Space in a research facility used for surgical procedures on animals.
	Veterinary Spaces			Spaces used for housing, treatment, training and other types of care for animals.
		Hospitalization Kennel		Space used for housing animals which require veterinary care.
		Infectious Disease Animal Holding Area		Space used for temporary segregation of animals who have or are suspected of having a contagious disease.
		Veterinary Radiography Control Room		Space used for the operator controls for a veterinary radiographic imaging system.
		Veterinary Radiography Procedure Room		Space used for veterinary radiographic imaging
		Veterinary Surgical Suite, Animal Preparation Room		Space used for the preparation of animals prior to surgery.
		Veterinary BSL3 Infectious Disease Suite Holding Room		Space used for temporary placement of animals in a biosafety level 3 suite.
		Veterinary Barrier Suite Holding Room		Space used where immune-suppressed animals are present to prevent entrance of harmful agents.
		Veterinary Examination and Treatment Room		Space used for the examination and treatment of animals in a veterinary clinic or laboratory.
		Veterinary Quarantine Holding Room		Space used for segregation of animals who may have contagious diseases or infections.
		Veterinary Surgery Room		Space used for surgical procedures on animals.
		Cage Wash Area		Space used for manual or automatic animal cage washing.

Level 1 Title	Level 2 Title	Level 3 Title	Level 4 Title	Definition
		Veterinary Food Preparation Room		Space used to prepare food for animals, including special diets for research animals.
Laboratory Spaces				Space that has built-in equipment, plumbing, and/or utilities for the qualitative and/or quantitative analysis of matter, experimentation, or the processing of materials, including wet and clean laboratories.
	High Risk Laboratory (High Risk Operation)			A High Risk Laboratory is any space solely dedicated to biological, microbiological, chemical, and/or physical testing, analysis and/or research activities, that also include, but is not necessarily limited to the use or handling of: oxidizers, toxic substances, peroxides, infectious agents, radioactive materials, and flammable substances.
	Chemistry Laboratories			A laboratory for research in chemistry. Includes Organic Chemistry Laboratories, Inorganic Chemistry Laboratories, Analytical Chemistry Laboratories, and Biochemistry Laboratories.
	Biosciences Laboratories			Spaces with shared equipment or housing specialized functions including fume hoods and biosafety equipment.
	Physical Sciences Laboratories			Spaces for building experiments with a minimum of built-in furniture where power and piped services are usually provided overhead
		Optical Physics Laboratory		Spaces requiring light control
		Physics Research Laboratory		Specialized spaces with extensive controls over the surrounding environment.
	Astronomy Laboratories			
		Astronomy Research Laboratory		Field based observation facilities and office based computational facilities
	Earth and Environmental Sciences Laboratories			
		Geology Laboratory		Often requires extensive storage of samples
		Earth Sciences Research Laboratory		Field based sciences that require processing of field samples from a dirty sample to very clean analytical equipment with a strong overlap to chemistry and applied engineering

Level 1 Title	Level 2 Title	Level 3 Title	Level 4 Title	Definition
	Forensics Laboratories			Spaces with high performance standards for cleanliness, temperature, humidity, and vibration controls.
	Psychology Laboratories			Open and flexible spaces that can be set up to accommodate many different types of studies. May have animal use
	Bench Laboratories			Space specifically used in development and testing of equipment and circuitry.
	Dry Laboratories			Space used in the development and/or testing of hardware including semiconductors and optics.
	Integration Laboratories			Laboratory designed for assembly and testing of components and sub assemblies, mechanical and electronic.
	Wet Laboratories			Space used in the development of test materials, processes, or equipment that involve the use of liquids and gases; usually chemical and biotechnology work.
	Laboratory Storage Spaces			Storage space adjacent to laboratory facilities and is specifically designed for storage of lab materials such as gas canisters, etc.
	Laboratory Support Spaces			Space which is used for support services directly related to the use of the laboratory.
Commerce Activity Spaces				Spaces where customers or clients view, sample, purchase and return product or where business, clerical or professional activities are conducted
	Office Spaces			Space in which business, clerical or professional activities are conducted.
		Office Service		A space that directly serves an office or group of offices as an extension of the activities in those spaces.
		Dedicated Enclosed Workstation		An enclosed space used as one workstation occupied by a particular person on an ongoing basis.
		Shared Enclosed Workstation		An enclosed space used as one or more workstations by a variety of persons who are not specifically assigned to a particular workstation.
		Dedicated Open Workstation		An non-enclosed space used as one workstation occupied by a particular person on an ongoing basis.
		Shared Open Workstation		An non-enclosed space used as one or more workstations by variety of persons who are not specifically assigned to a particular workstation.

Level 1 Title	Level 2 Title	Level 3 Title	Level 4 Title	Definition
		Open Team Setting		A free-address space that is designed to be used by a group of people working together with no fixed workstation assignments.
		General File and Storage		Space set aside for storage of material that is used by an area, group of persons or department.
		Shared Workstation File and Storage		Space designated for the materials used by persons using shared workstations.
		Shared Equipment Station		Space set aside for office equipment used jointly by the occupants in the immediate area.
		Lookout Gallery		Space used to observe employees in work areas performing work-related functions. This includes the ladder rooms to access the lookout gallery.
	Banking Spaces			Space specific to banking such as teller spaces, vaults, safety deposit space and automated teller machines.
		Bank Teller Space		Area fit-up for face to face customer service usually over a counter
		Automatic Teller Machine Space		Area associated with a wall mounted banking machine and space for the user to access the machine
		Vault		A reinforced room or compartment in a bank building where valuables are stored
	Trading Spaces			Open space used for security or commodity trading.
		Trading Floor		Area used to facilitate the communication between professionals on a stock exchange or futures exchange which involves shouting and the use of hand signals to transfer information primarily about buy and sell orders, also know as the pit.
	Demonstration Spaces			Space where the product is demonstrated in an operational setting; often for large and/or complex operations and products.
	Sales Spaces			Space where customers or clients can view or purchase product.
		Checkout Space		Space with counters and product sales/returns equipment
		Display Space		Space used to display articles for sale including associated circulation area.
		Fitting Space		Space supporting clothing/footwear/sports equipment sales providing customers opportunity to try on products and/or have them sized for alterations

Level 1 Title	Level 2 Title	Level 3 Title	Level 4 Title	Definition
		Vending Machine Area		Space accommodating vending equipment for non-perishable goods
		Auction Room		A space to accommodate a regularly occurring auction process, such as those for automobiles or livestock. This space will often contain special furnishing for displaying the items being bid on, as well as a raised platform for the auctioneer and assistants, and audio visual and lighting enhancements needed to support the auction..
		Pet Shop Animal Space		Space for the display of animals, insects, fish and birds that would require additional equipment (cages/aquariums) and associated plumbing, power and ventilation.
	Commercial Service and Repair Spaces			Space designed for the service or repair of product, including customer waiting and stockrooms for replacement parts as part of the customer-facing operation.
	Commercial Support Spaces			Space for storage room, back office and other support functions required for Commercial Space.
	Hotel, Motel, Hostel, and Dormitory Service Spaces			Spaces used for lodging on a short-term basis.
		Dormitory		Space where two or more persons are housed in the same room or share restroom facilities.
		Hotel Residence Room		Private residence room in a hotel or motel for lodging on a short-term basis.
	Commerce Activity Support Areas			Space housing functions supporting the business process or secondary business functions.
		Information Counter		A space where visitors can ask questions, get directions, or pick up pamphlets and other basic informational materials.
		Lobby Non-Circulation Space		Portions of the Lobby, which are used for purposes other than circulation and are not readily designated as another classification.
		Post Office Space		Specialized space in a facility that houses United States Postal Service operations.
		Mail Room Space		Mail sorting and distribution space including remote mail stops on floors.
		Box Lobby		Lobby with post office-type boxes. Usually assigned to U.S. Postal Service.

Level 1 Title	Level 2 Title	Level 3 Title	Level 4 Title	Definition
		Meeting Spaces		Space specifically designed for groups of people to interact on an occasional basis having appropriate seating and other amenities to support this activity.
			Conference Room	Any office room used primarily as a conference room by a single tenant
			Press Conference Room	A room to accommodate a media event in which newsmakers invite journalists to hear them speak and, most often, ask questions; this room often includes a podium, seating for the press, and audio-visual, communications, power, and lighting enhancements to accommodate the work of broadcast journalists.
			Community Room	An often public space for community organizations to carry out meetings and programs
			War Room	A single location from which any activity is directed.
			Meeting Equipment Room	Audio/Visual equipment rooms associated with conference rooms, courtrooms, and auditoriums. Room used to house radio equipment and/or conduct associated activities.
		Waiting Space		Space with seating where people wait prior to entering another space or receiving service.
			Reception Space	A waiting area, such as a lobby or front office desk of an organization or business.
			Waiting Room	A room in some public space for people to wait.
			Queuing Space	A waiting space used to organize people into a first-come-first-served order.
		Business Support Space		Any other business service space that is not readily categorized into one of the other classes.
Service Activity Spaces				Space for conducting commercial activities and those in support of personal needs.
	Grooming Activity Spaces			Spaces for cleaning, grooming, or maintaining parts of the body, including primping, hair dressing, shaving, and providing manicures and pedicures.
		Makeup Space		Space for the professional application of cosmetics and makeup, often used in the entertainment or fashion industries
		Haircutting Space		Space used by barber or hair dresser to conduct said business.

Level 1 Title	Level 2 Title	Level 3 Title	Level 4 Title	Definition
	Food Service			Space used for preparation and serving of food or providing seating for dining.
		Cooking Spaces		Spaces used for preparation of food.
		Kitchen Space		A room or area for preparing and cooking food.
			Food Preparation Space	Space for the preparation of food that does not require cooking, or for preparation of food for cooking.
			Cooking Space	Space for cooking food.
			Dishwashing Station	Area and equipment for the cleaning of cooking and serving utensils
		Dining and Drinking Spaces		Spaces used for the serving and consumption of food and beverages, or providing seating for dining.
			Dining Room	A room in a home or hotel, or a private area in a restaurant away from the main public area, where meals are eaten.
			Banquet Hall	A space that can accommodate large groups for dining and where celebratory meals may be eaten.
			Food Court	A common area for dining, containing or surrounded by contiguous counters of multiple food vendors.
			Snack Bar	A small restaurant serving light meals or a counter in some other establishment having the same function.
			Salad Bar	A buffet space for self-serving salad and cold food.
			Liquor Bar	The serving counter space of a business licensed to sell intoxicating beverages for consumption on the premises or a similar device or area containing alcoholic beverages in a private house or a hotel room.
			Beverage Station	A space, often self-serve, for preparing consumable liquids, including tea, coffee, liquor, beer, milk, or soft drinks.
			Table Bussing Station	A space in restaurant or dining area for collecting dirty dishes and storing silverware and supplies for cleaning and refreshing tables.
			Serving Station	A space for the final preparation or assembling of meals before serving.
			Vending Perishable Product Space	A space for housing coin-operated, automatic machines that dispenses foodstuffs.
			Cafeteria Vending Space	Space in a cafeteria or dining hall in which customers select their food at a counter.
			Tray Return Space	A space in a Dining Hall or Cafeteria where serving trays are returned by customers and stacked before washing.

Level 1 Title	Level 2 Title	Level 3 Title	Level 4 Title	Definition
			Food Discard Station	Space set up to receive soiled service ware (dishes, cutlery etc)
		Coffee stations		Room or area used by employees during break times. This may include a service unit and can BREAK also contain miscellaneous storage, localized mail stop facilities, and other miscellaneous office amenities.
	Child Care Spaces			Spaces designed for the care of a young child or children
		Daycare sickroom		A room in a day care facility to be used by a child who is ill.
		Child Day Care Space		A space for the daytime supervision of children.
		Play Room		A room, allocated as a children's play area, in which noisy or boisterous activities are tolerated. (NEW TITLE: Playroom?)
	Resting Spaces			A space where one can rest.
		Rest Area		A place on the interstate where one can stop to use the restroom, rest or do other things.
		Break Room		A room at a business which is set aside for coffee breaks, snacks, lunches, etc. Synonym: Lunchroom
	Laundry/Dry Cleaning Space			Space that provides large-scale laundry and/or dry cleaning operations, or personal coin operated laundry equipment.
	Smoking Space			Space that is designed specifically for smoking.
Production, Fabrication, and Maintenance Spaces				Spaces where manufactured items are created or maintained.
	Material Handling Area			Space for the movement, storage, control and protection of materials, goods and products throughout the process of manufacturing, distribution, consumption and disposal
	Batching Space			Space for the preparation of mixtures in manufacturing and process plants
	Production Process			Space where items are fabricated and/or assembled using a materials process.
		Workbench	Workbench	Space accommodating a component supporting production, fabrication, testing or maintenance functions
		Mock-up Space	Mock-up Space	Space accommodating a function supporting production

Level 1 Title	Level 2 Title	Level 3 Title	Level 4 Title	Definition
	Printing and Reproduction Spaces			Space for the reproduction and distribution of documents.
	Quality Control and Test Spaces			Space where items are tested and inspected.
		Product Inspection Space		Space for the direct evaluation of a product in production
		Production Observation Space		Space for the observation of the operation of a product in production
	Production Service and Repair Spaces			Space where items are corrected for defects.
	Production and In-Process Storage Spaces			Space for raw material or work in process within the production process.
	Production Support Spaces			Space to support the functioning of other production space.
	Greenhouse Spaces			A space used for growing in a facility with glass walls and roof in which temperature and humidity can be regulated for the growing and protection of plants.
		Greenhouse Support Space		Space housing equipment supporting a greenhouse
Protective Spaces				Spaces to provide shelter or keep someone safe from harm or discomfort.
	Animal Securing Spaces			A space that directly serves an animal quarters facility as an extension of the activities in that facility.
		Cage		A typically small, freestanding, wire enclosed space for detaining an animal or bird
		Animal Stall		An enclosed floor space, typically open to the structure ceiling for detaining an animal.
		Kennel		An enclosed, typically permanent, floor space generally used to detain a dog or cat
		Aquarium		An tank, containing or filled with water, generally used to detain a fish or marine animal.
	Detention Spaces			Space associated with the holding of humans as prisons, criminals or people suspected of committing a crime.
		Detention Cell		An enclosed floor space use to confine a convicted person(s) for an extended period of time in a particular place

Level 1 Title	Level 2 Title	Level 3 Title	Level 4 Title	Definition
		Holding Cell		An enclosed floor space use to confine a person(s) of interest for a very short period of time in a particular place
		Impound Lot		An area used to secure vehicles from general access of the public
		Dayroom		A room associated with enforced confinement which is used for daytime recreation, esp. a communal room in an institution.
	Spaces for Protection from the Elements			Spaces to provide shelter or keep someone safe from environmental harm or discomfort.
		Park Shelter		A pavilion structure commonly found in parks, gardens, and spacious public areas. See also Gazebo.
		Entry Porch		A covered entrance to a vestibule or doorway attached to a building.
		Covered Walkway		A sidewalk or path with a cover to provide shelter from weather or sunlight.
		Canopy		An overhead roof or structure that is able to provide shade or shelter.
		Shielded Room		Space with protection from radiation or other harmful effect, often adjacent to a space in which radioactive or other harmful materials may be used.
		Containment Room		Space with shielding for radiation or biological harms inside of which harmful materials can be used.
	Spaces for Protection from Violence			Spaces to provide shelter or keep someone safe from violent or force-based harm or discomfort.
		Safe Room		A fortified room installed in a private residence or business to provide a safe hiding place for the inhabitants in the event of a break-in, home invasion, or other threat.
		Bunker		A hardened shelter, often buried partly or fully underground, designed to protect the inhabitants from falling bombs or other attacks.
		Bomb Shelter		A space for the protection of the civil population as well as military personnel against bombing from the air.
Storage Spaces				
	Warehouse Spaces			Space specifically designed for the storage of raw material, in process materials or finished goods.

Level 1 Title	Level 2 Title	Level 3 Title	Level 4 Title	Definition
		High Bay Warehouse Space		Warehouse space with usable storage heights at 24' or higher.
		General Warehouse Space		Warehouse space with usable storage heights of less than 24 feet.
		Warehouse Support Space		Space that directly supports warehouse functions.
	Non-Warehouse Storage Spaces			Spaces for the storage of goods and materials for long and short terms
		Storage Room		A room that is used to store equipment or materials and that serves multiple room use categories, organizational units, or buildings.
		Small Arms Ammunition Storage		Storage of a shotgun, rifle, or pistol-cartridge for propellant-actuated devices. This definition does not include military ammunition containing bursting charges or incendiary, trace spotting or pyrotechnic projectiles.
		Closet		Small room used for containment of work-related items.
		Coat Check		Space for the temporary storage of outerwear and other personal items during events or at entertainment facilities
		Locker Room		Room containing lockers or small lockable cupboards or compartments in which people secure possessions.
		Filing Space		Space for filing cabinets and storage of paper materials
		Supply Room		Room for storage of regularly used supplies, such as in an educational or office facility
		Unit Storage		A dedicated storage area or location at an educational facility under the direct control and management of a specific institutional division, department, office, business unit, or similar organizational unit
		Consolidation/ Containerization Point		Space for outloading, stuffing, and receiving containers
		Self Storage Space		A space in a facility divided into storage spaces that are rented to tenants, usually on a monthly basis
		Operational Storage (Misc)		A space used for bulk storage areas of major end items, and operational material to support multiple Departments/Divisions within a command.

Level 1 Title	Level 2 Title	Level 3 Title	Level 4 Title	Definition
		Explosives and Explosive Material Storage (High Risk Operation)		Any chemical compound mixture, or device, the primary or common purpose of which is to function by explosion. Explosives and Explosive Materials include, but are not limited to, the following materials: dynamite, black powder, pellet powder, initiating explosives, detonators, detonating cord, igniters, igniting cord, emulsion explosives, safety fuses, water gel, blasting agent, squibs, and other similar high explosives.
		Operational Hazardous/ Flammable Storage		A space for the storage of materials used in daily operations (paint, acetone, oil, etc.) that are considered to be hazardous and/or flammable and require special environmental separation.
	Moveable Storage Spaces			Spaces, which do not have a fixed location, used for the storage of goods and materials for long and short terms
		Vehicle Storage Compartment		A storage space in a vehicle designed to move on land
		Portable Bin		Movable storage container, used for relocation or temporary storage purposes
		Vessel Hold		A storage space in a vehicle or craft designed to move across (or through) water
	Environmentally Controlled Storage Spaces			A facility for cooling and storage of materials at the depot level.
		Refrigeration Compartment		Space served by refrigeration equipment, used to lower the internal temperature, often for the purposes of storing perishables.
		Freezing Compartment		Space served by equipment to lower the internal temperature below the freezing point of water, often for the purposes of storing perishables.
		Humidity Controlled Storage Space		A space for storage of materials at a controlled humidity at the depot level.
		Vacuum Sealed Storage Compartment		Space served by equipment to provide lowered air pressure, often for the purposes of storing perishables.
	Specialty Storage Spaces			Spaces for the storage of goods and materials in specialized ways or of special quality or type for long and short terms
		Sanitary Storage Room		Space for the storage of sterile or clean items, often in a healthcare setting

Level 1 Title	Level 2 Title	Level 3 Title	Level 4 Title	Definition
		Soiled Storage Room Space		Space for the storage of used or dirty items prior to cleaning or discard, often in a healthcare setting
		Sacristy		A room for keeping vestments (such as the alb and chasuble) and other church furnishings, sacred vessels, and parish records.
		Vestry		A room within or attached to a church which is used to store vestments and other items used in worship. It is usually of sufficient size to allow those using vestments to change into them, and thus in England and elsewhere was often used for meetings dealing with the administration of the local parish.
		Hazardous Material Storage Space		A facility for the storage of hazardous materials at the depot level.
		Book Stacks		Space for the storage of printed material, with specialized shelving and environmental controls suitable to that task.
		Baggage Claim		A space in an airport terminal or other transportation hub where one claims checked-in baggage after disembarking.
		Evidence Room		A secure room where vital evidence is kept until it can be used in court or in the investigation and prosecution of a crime.
		Vehicle Impound Lot		A space for the storage of abandoned, towed, or disabled vehicles, either for short term prior to claim by their owners, or for longer term prior to auction or disposal.
		Operating Fuel Storage		Storage tanks that provide an operating and reserve supply of fuel. Cost factors are based on a 5000 GA tank.
Private Residential Spaces				Space used to provide accommodation for people when not at work. The accommodation provides facilities for sleeping and relaxation and usually cooking, eating, cleaning,
	On-call Room			Space where workers on standby are able to sleep, such as in hospitals.
	Bathroom			Either a "full bathroom," containing a bathtub or shower, toilet, and sink or a "half (1/2) bath" (or "powder room") containing just a toilet and sink.
		Shower Space		A space in which one bathes underneath a spray of water.
		Toilet Space		A space containing a toilet or similar fixture that disposes of human waste by using water to flush it through a drainpipe to another location.

Level 1 Title	Level 2 Title	Level 3 Title	Level 4 Title	Definition
		Ablution Room		Space for washing one's body or part of it.
		Combination Toilet and Bathing Space		Space used for both toilet and bathing functions and related personal grooming
	Mud Room			An entryway or hall that is generally located at the front entrance of a house, designed to be an easy-to-clean transition space.
	Laundry Room			A room where clothes are washed.
	Bedroom			A private room where people sleep for the night.
		Mental Health Resident Bedroom		Space used in non-acute healthcare settings to provide sleeping accommodations for a resident.
		Mental Health Resident Bedroom, Bariatric		Space used for housing residents who are morbidly obese in a non-hospital, residential setting.
	Nursery			A bedroom within a house or other dwelling set aside for an infant or toddler.
	Kitchen			A room or part of a room used for cooking and food preparation.
Alternate Workplace				Space that is used to accommodate employees during the workday but which are not part of the institution's real estate portfolio.
	Customer Site			Specific dedicated space at a customer's site which is used by employees.
	Home Office			Space used as an office within the home of an employee.
	Rent-An-Office			A short-term office rental which is typically by the room and may have office services provided.
	No Fixed Location			The implied space to support personnel who have no designed work location.
	Supplier Site			Specific dedicated space at a supplier site which is used by employees.
Building Associated Spaces				
	Roof			A construct oriented more than 15° from vertical that Encloses the interior of a Building underneath from the exterior above, affording protection from the elements appropriate to the occupancy and the local climate.

Level 1 Title	Level 2 Title	Level 3 Title	Level 4 Title	Definition
	Roof Terrace			An unenclosed horizontal Roof (other than a Plaza) with a Load Bearing surface intended for use along with other appropriate and required features such as railings.
	Penthouse			Fully enclosed Floor area located on the Roof level of a Building that occupies less than all of the Roof.
	Antenna Farm			Space designed to support communications antenna.
	Heliport			Space designed to support the arrival and departure of helicopters.
	Balcony			A horizontal extension of an adjacent floor outside the exterior enclosure of a building that is not a roof.
	Deck			An unenclosed surface contiguous with a Building that is suitable for use by an occupant and supported by structure above the ground.
	Pedestrian Travel Spaces			Spaces for travel by people on foot.
		Sidewalk		A pathway constructed to support pedestrian traffic. Construction is of concrete, asphalt, paving blocks, gravel, or the like.
		Pedestrian Way		A decorative path for travel by people on foot.
		Pedestrian Bridge		Bridges that support walkway crossing of a river, underpass, or similar gap.
		Footpath		Trail, which runs through a park or rural area, or which is a path of travel for recreation and/or transportation within a park, natural environment, or designated corridor that is not classified as a highway, road, or street.
		Trail		A simple thoroughfare used for travel on foot or possibly by horse, bicycle or other simple device that is not a highway or associated with a highway
		Gangway		An aisle or walkway between apartment buildings or houses, or any raised walkway or platform

Appendices



A. Space Assignment Data Matrices

Space Class Assignment Data Matrix

The following matrix depicts the relationship between PBS Space Class, PBS Space Category, and ANSI category.

PBS Space Class	PBS Space Category			ANSI Category
	Assigned	Unassigned	Joint Use	
CRV–Circulation Vertical	n/a	10–Unmarketable	n/a	04–Vert. Penetration
CON–Construction	n/a	10–Unmarketable	n/a	05–PBS Specific
STP–Structured Parking				
UFO–Unsuitable for Occupancy				
OTB – Open to Below	01– Assigned	04–Committed 11– Vacant	03–Building Joint Use 07–Facility Joint Use 15–Lease Joint Use 16– Community Joint Use	01–Office
ADP–Automated Data Processing				
AUD–Auditorium				
CFT–Conference/Training				
CLD– Child Care				
CRJ–Courtroom/Judiciary				
FDS–Food Service				
FIT–Fitness Center				
GNS–General Storage				
HUT–Health Unit				
INS–Light Industrial				
JCC–Judicial Chambers				
JHR–Judicial Hearing Room				
LAB–Laboratory				
PTL–Private Toilet				
QRR–Quarters and Residence				
STC–Structurally Changed				
TFC–Tenant Floor Cut				
TTO–Total Office				
WRH–Warehouse				
CRH–Circulation Horizontal	n/a	02–Building Common	n/a	02–Building Common 03–Floor Common
TLT–Toilet		06–Facility Common		
CST–Custodial		08–Lease Common	n/a	
MCH–Mechanical	n/a	14–Zero Square Feet 11 – Vacant (LND – Land Only)	n/a	05–PBS Specific
ANT–Antenna				
BDK–Boat Dock				
BRG–Bridge				
KIS–Kiosk				
LND–Land				
OTH–Other				
RRC–Railroad Crossing				
WYD–Wareyard				

Space Category Assignment Data Matrix

The following matrix shows the relationship between PBS Space Categories, Agency Bureau Codes, and Agency Space Assignment (ASA).

Notes:

1. Effective July 5, 2011, Client Billing Record (CBR) is now Agency Space Assignment (ASA)
2. For Space Categories where the ASA is not applicable (n/a), the space label is blank.

PBS Space Category	Agency Bureau (AB) Code	Agency Space Assignment (ASA)
01–Assigned	Agency	ASA – Draft or Final
04–Committed	Agency	Null
14–Zero Square Feet	Agency or Null	ASA or Null
	For Active Antenna Only – Agency	ASA
	For Vacant Antenna Only – Null	Null
	For Committed Antenna Only – Agency	Null
10–Unmarketable	VERT or BLDG or PRKN or CONS	n/a
11–Vacant	VCNT	n/a
02–Building Common 06–Facility Common 08–Lease Common	BLDG	n/a
03–Building Joint Use 07–Facility Joint Use 15–Lease Joint Use 16–Community Joint Use	JNTU	n/a
17–Excluded from Gross	VOID	n/a

A.3 - PBS Space Type and Space Category Relationship Matrix

Space Type	Abbrev.	Assigned New	Vacant	Committed	Bldg. Joint Use	Facility Joint Use	Lease Joint Use	Community Joint Use	Bldg. Common	Facility Common	Lease Common	Unmarketable	Zero Square Feet
AUTOMATIC DATA PROCESSING	ADP	Y	Y	Y	Y	Y	Y	Y					
AUDITORIUM	AUD	Y	Y	Y	Y	Y	Y	Y					
CONFERENCE/TRAINING	CFT	Y	Y	Y	Y	Y	Y	Y					
CHILD CARE	CLD	Y	Y	Y	Y	Y	Y	Y					
COURTROOMS/JUDICIARY	CRJ	Y	Y	Y	Y	Y	Y	Y					
FOOD SERVICE	FDS	Y	Y	Y	Y	Y	Y	Y					
FITNESS CENTER	FIT	Y	Y	Y	Y	Y	Y	Y					
GENERAL STORAGE	GNS	Y	Y	Y	Y	Y	Y	Y					
HEALTH UNIT	HUT	Y	Y	Y	Y	Y	Y	Y					
LIGHT INDUSTRIAL	INS	Y	Y	Y	Y	Y	Y	Y					
JUDICIAL CHAMBERS	JCC	Y	Y	Y	Y	Y	Y	Y					
JUDICIAL HEARING ROOM	JHR	Y	Y	Y	Y	Y	Y	Y					
LABORATORY	LAB	Y	Y	Y	Y	Y	Y	Y					
OFFICE	TTO	Y	Y	Y	Y	Y	Y	Y					
PRIVATE TOILET	PTL	Y	Y	Y	Y	Y	Y	Y					
QUARTERS AND RESIDENCE	QRR	Y	Y	Y	Y	Y	Y	Y					
STRUCTURALLY CHANGED	STC	Y	Y	Y	Y	Y	Y	Y					
TENANT FLOOR CUT	TFC	Y	Y	Y	Y	Y	Y	Y					
WAREHOUSE	WRH	Y	Y	Y	Y	Y	Y	Y					
CIRCULATION HORIZONTAL	CRH								Y	Y	Y		
CUSTODIAL	CST								Y	Y	Y		
MECHANICAL	MCH								Y	Y	Y		
TOILET	TLT								Y	Y	Y		
CIRCULATION VERTICAL	CRV											Y	
CONSTRUCTION	CON											Y	
STRUCTURED PARKING	STP											Y	
UNSUITABLE FOR OCCUPANCY	UFO											Y	
ANTENNAS	ANT												Y
BOAT DOCK	BDK												Y
BRIDGE	BRG												Y
KIOSK	KIS												Y
LAND	LND												Y
OTHER	OTH												Y
RAILROAD CROSSING	RRC												Y
WAREYARD	WYD												Y

Note: PBS Space Type is now Space Class

B. Methodology Used to Measure Space

Dominant Portion

Dominant Portion is defined by ANSI/BOMA as, “the portion of the inside, finished surface of the permanent, outer, building wall, which is 50% or more of the vertical floor-to-ceiling dimension at the given point being measured horizontally along the wall.” PBS uses the ANSI/BOMA definition of Dominant Portion without deviation.

The area inside the Dominant Portion is defined as the Gross Measured

Area. To determine the Dominant Portion, refer to the following examples.

Illustration B-1: Dominant Portion is the section of the inside, finished surface of the permanent, outer, building wall which makes up 50% or more of the vertical floor-to-ceiling dimension.

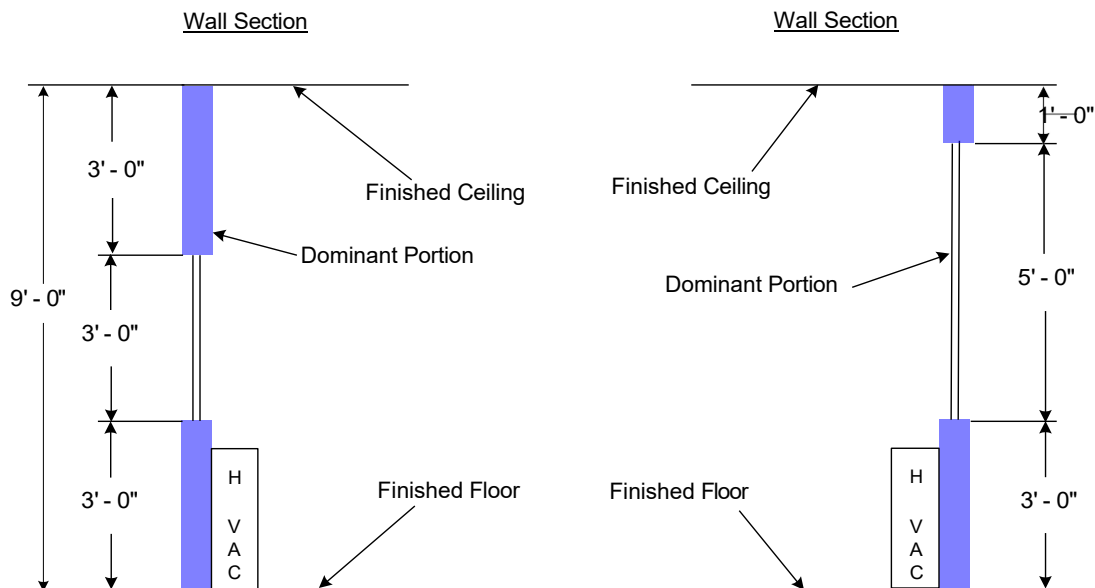

Illustration B-2: If no finished surface of the permanent, outer building wall is 50% or more of the vertical floor-to-ceiling dimension (as shown in the left diagram), or if the permanent, outer building wall is not vertical, the Dominant Portion is the inside, finished surface of the wall where the wall intersects the finished floor (as shown in the right diagram).

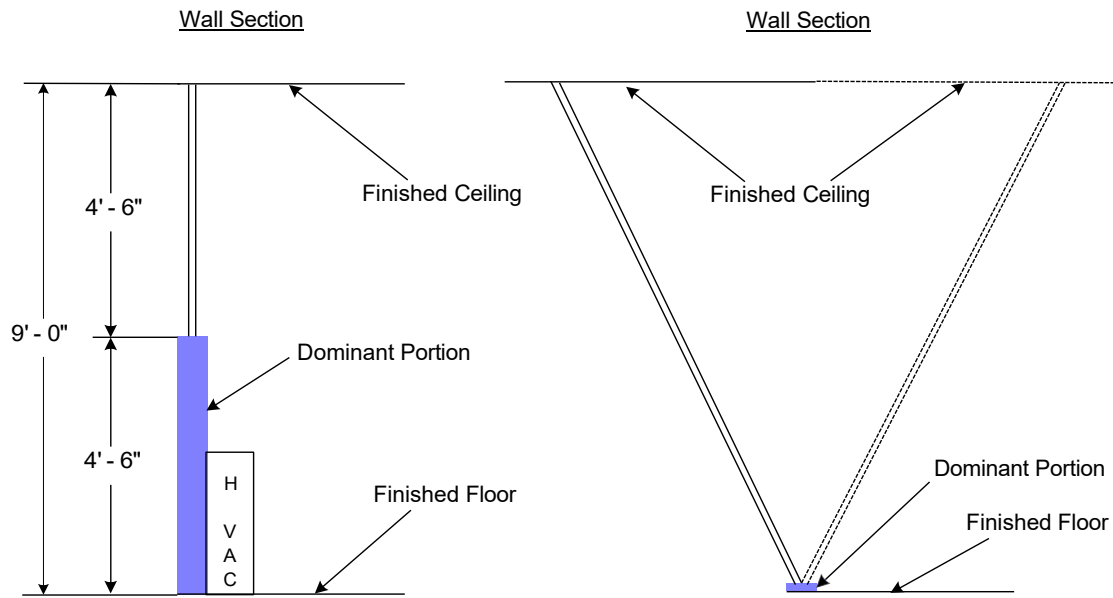
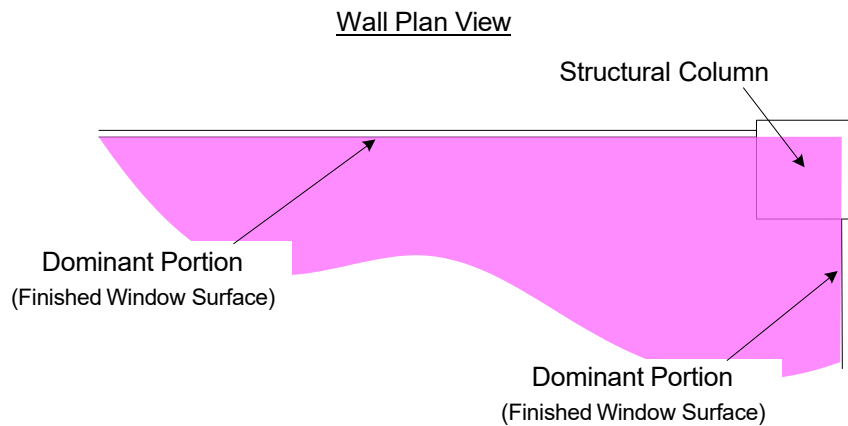
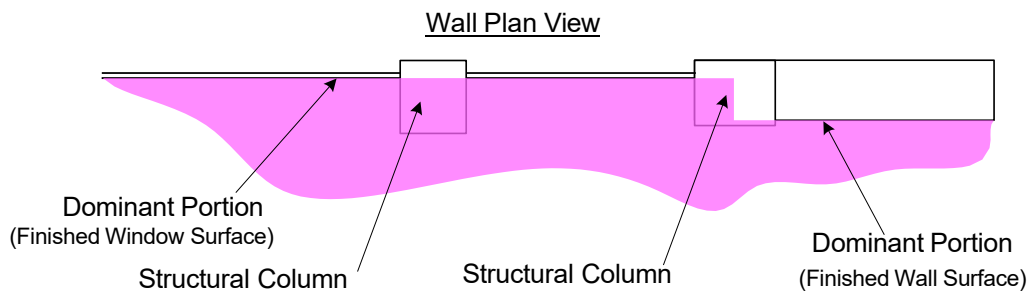
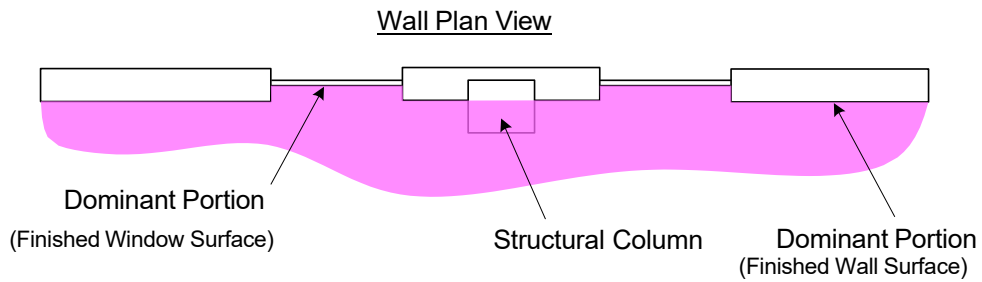

Illustration B-3: In the three examples below, if an alternating window system results in the Dominant Portion moving from the finished surface of the wall to the face of the glass, the space boundary moves in and out as often as conditions dictate and the structural columns are ignored.



Space Boundaries

Space boundaries determine a space's area in square footage and are created in a CAD file using area lines known as polylines. Space boundaries (or space polygons) can be used to graphically display precisely where one space or room begins and another ends. Space boundaries are the most basic component of any Computer Aided Facilities Management (CAFM) system.

Space boundaries (space polygons) are used in three ways by SDM:

1. To measure area (in usable square feet) by room (a physical construction) or by a space (a theoretical area)
 - o A room can contain multiple spaces
 - o A space can contain multiple rooms
2. To graphically display where a space or room begins and another ends.
3. To graphically display an occupant's suite of space, or any available thematic of the user's choice.

The placement of space boundaries is done according to the following hierarchy which is also found in ANSI-BOMA under section titled "Wall Priority." (This hierarchy is presented as if one were adding area lines to a drawing).

1. The floor boundary is located on the outside building line (the floor boundary indicates the Gross Floor Area with Voids included). The Gross Measured Area line is then located on the Dominant Portion on the interior side of the exterior wall. These two lines form the Construction area of the building shell. The Construction area takes precedence over all other area lines.
2. ANSI 04–Vertical Penetration lines are drawn next. The Vertical Penetration lines include the wall thickness of the enclosing walls except for the outside building wall Construction area.
3. ANSI 02–Building Common and ANSI 03–Floor Common lines are drawn after all lines for Vertical Penetrations have been drawn. The Building and Floor Common lines envelop the wall thickness of all enclosing walls except for the outside building wall Construction area and Vertical Penetrations.

Note: For the purpose of placing area lines, ANSI Category 02–Building Common areas and ANSI Category 03–Floor Common, both areas are treated the same.

4. ANSI 01–Office area lines are drawn after all lines for Building and Floor Common have been drawn. Adjoining office spaces split (or share) the wall equally between the spaces.
5. ANSI 05–PBS Specific is assigned in special circumstances.
When ANSI 05–PBS Specific is assigned to Unsuitable for Occupancy (UFO) the line is placed where the space was originally constructed. For example, if the space is constructed as Office Space, the area line is drawn as ANSI Category 01–Office Space. Further, if the space was constructed as Building Common space, the area line is drawn as ANSI categories 02–Building Common or 03–Floor Common.

Note: When ANSI 05–PBS Specific is assigned to Structured Parking (STP) the area line includes the enclosing wall when adjacent to ANSI Categories 01–Office Space, 02–Building Common, and 03–Floor Common. When Structured Parking is adjacent to 04–Vertical Penetration, the wall is split between Structured Parking and the Vertical Penetration.

To determine the placement of space boundaries, refer to the following examples.

Illustration B-4 (Wall Plan View): If two adjoining spaces have the same ANSI classification, the wall is shared equally between the spaces.

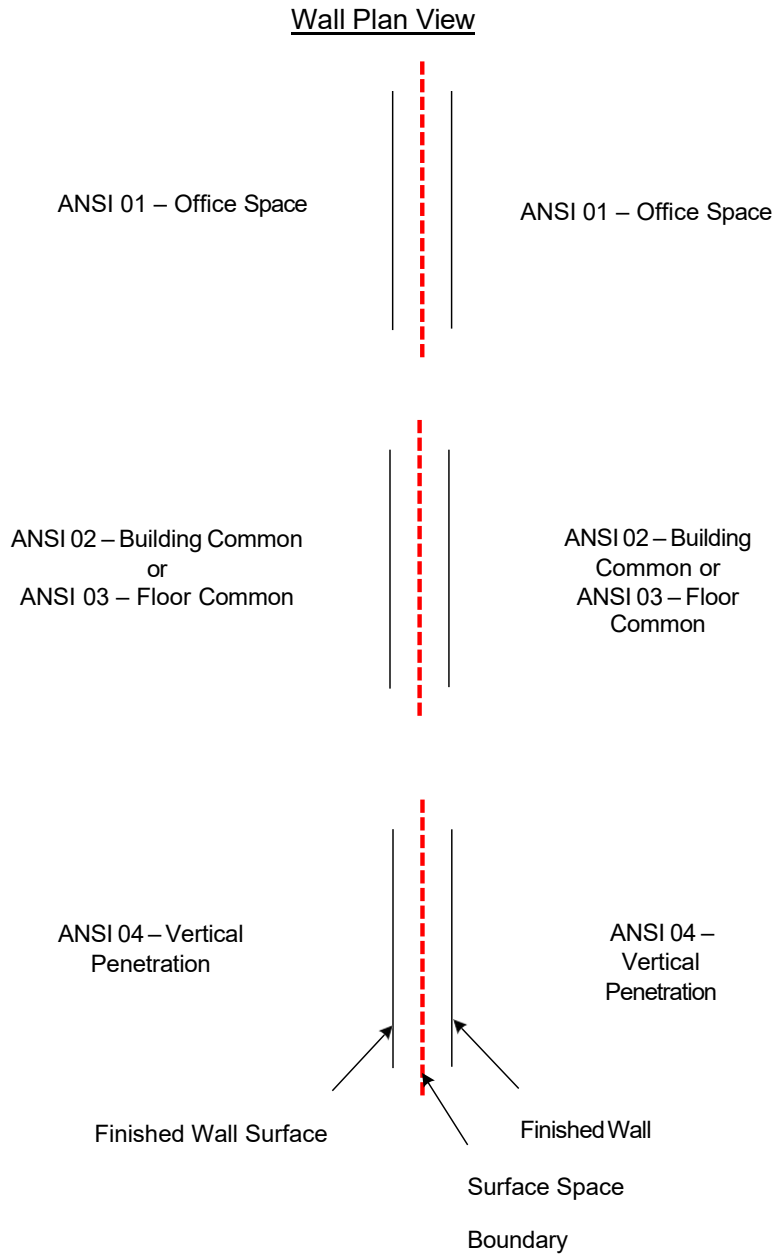

Illustration B-5 (Wall Plan View): If one space is ANSI 04 (CRV) or ANSI 05 (OTB) and the adjoining space is ANSI 01, ANSI 02, or ANSI 03, the ANSI 04 and ANSI 05 space includes the wall thickness represented as the space between the parallel lines.

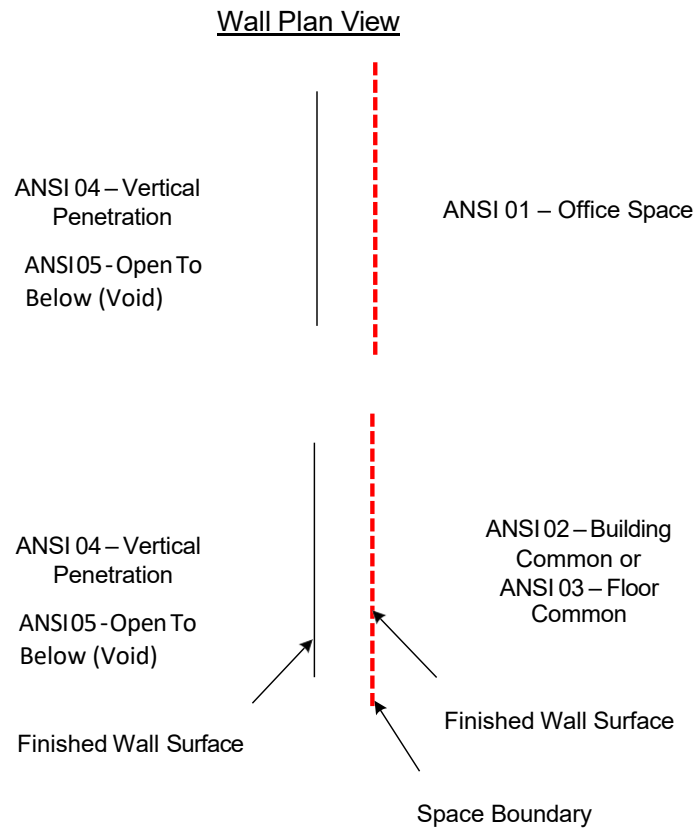
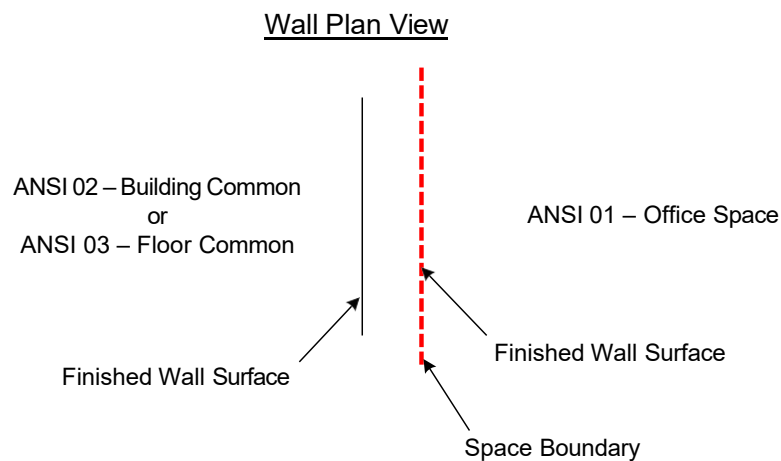

Illustration B-6 (Wall Plan View): If one space is ANSI 02 or ANSI 03 and the adjoining space is ANSI 01, the ANSI 02 or ANSI 03 space includes the wall thickness represented as the space between the parallel lines.



Wall Plan View B-7 (Wall Plan View): If one space is ANSI 04 CRV or ANSI 05 STP or ANSI 05 OTB and the adjacent space is any of the same ANSI 04 CRV or ANSI 05 STP or ANSI 05 OTB, the wall thickness will be split.

Note: In general, treat OTB (Open to Below) Voids in the same manner as Vertical Penetrations when placing space boundaries.

Wall Plan View

ANSI 04 Vertical Penetration, ANSI 05 Structured Parking or ANSI 05 Open To Below (Void)

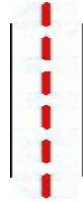

ANSI 04 Vertical Penetration, ANSI 05 Structured Parking or ANSI 05 Open To Below (Void)

Illustration B-8: This is an example of common adjacencies in a standard floor plan with regard to area line placement when creating space boundaries.

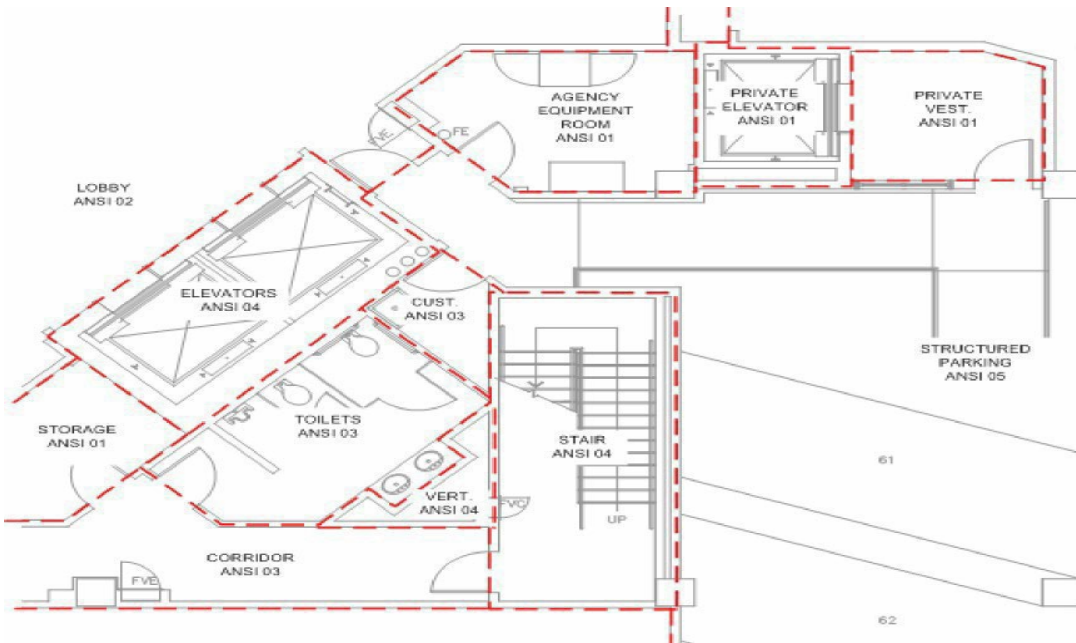

Unique Cases

The following unique cases are treated as exceptions to the criteria defined in this section.

Excessive Column Sizes

If the perimeter columns are greater than 25 square feet, whether due to the era of construction or seismic upgrades, the Dominant Portion is defined as the finished surface of the column enclosure and area lines are drawn to include the area of the columns with the Construction area. This exception applies only to columns at the outer perimeter of the building.

Illustration B-10 (Wall Plan View): Example of a wall plan view showing placement of area lines to demonstrate Dominant Portion interrupted by a structural column.

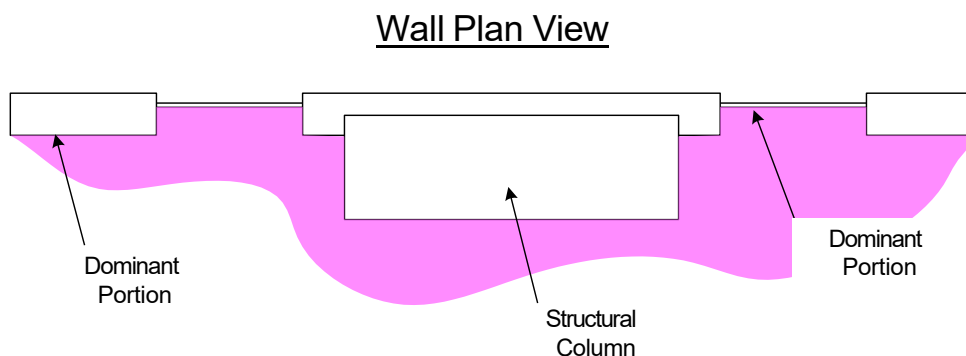

Alcoves and Recesses

If occupant entries are recessed from the corridor, creating an alcove or recess (typically to accommodate the swing of the entry door), the area lines are drawn to continue straight across the recess and to include the area of the recess with the assigned occupant space.

Illustration B-11 (Plan View): If an alcove or recess exists from the common corridor, the area line is drawn straight across so the area of the recess is included in the occupant space.

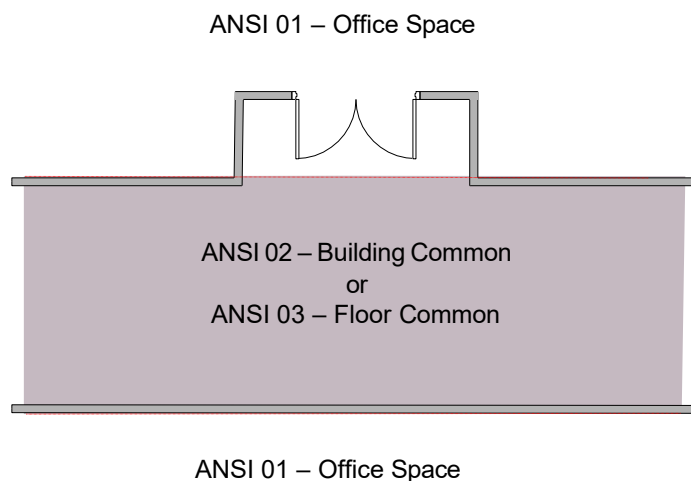
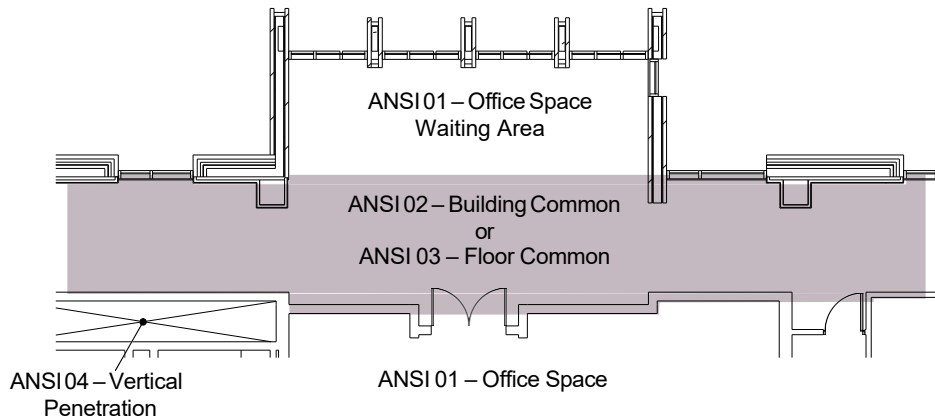

Illustration B-12 (Plan View): If a recess exists from the common corridor, the area line is drawn straight across so the area of the recess is included in the occupant space.

Note: Public Waiting Areas are frequently found in Courthouses. They are assigned to the tenant under the following conditions: if they are architecturally distinct such as a recessed or alcove area or if features and/or other fixtures are added that make the space distinct and distinguishable or exhibit some control by the tenant, or Public Waiting Areas are called out in the tenant's Program of Requirements. Contact your regional SDM team for more information.



Private Stairs and Elevators

Private stairs and elevators are classified as ANSI 01–Office Space and treated as ANSI 04–Vertical Penetrations. They typically include the enclosing walls unless the adjacent space is also ANSI 04–Vertical Penetration. The resulting spaces are then assigned to the occupant as Tenant Floor Cut (TFC).

Illustration B-13: The area lines for private stairs and private elevators are drawn the same as for public stairs and public elevators.

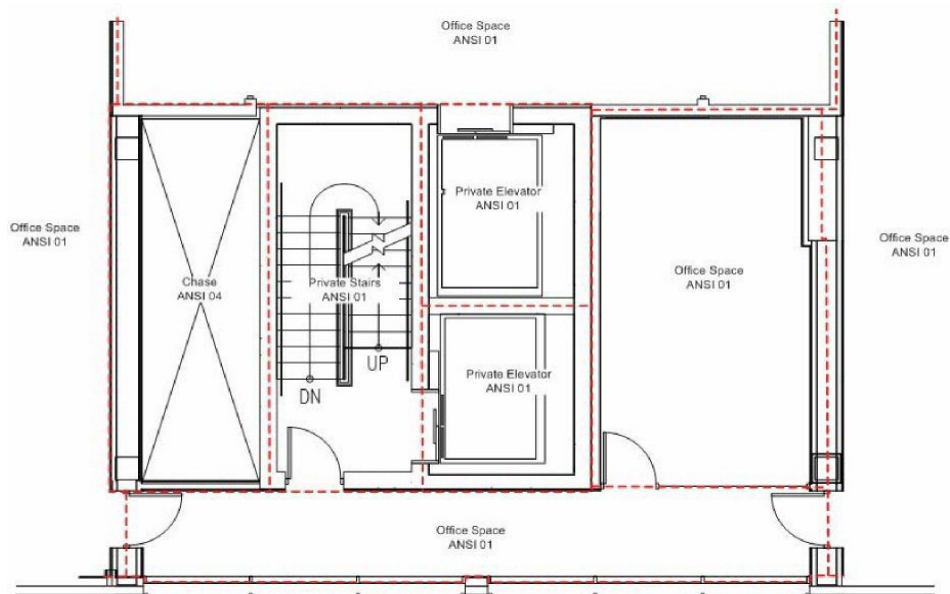

C. Examples of Special Architectural Situations

Areaway

Many Federal buildings have areaways. They are small sunken areas that allow access or light and air to basement doors or windows.



Example of an unenclosed areaway.

If this areaway were covered with steel grating, it would still be considered unenclosed.

If this areaway were covered with steel panels and/or a door or a roof, it would be considered enclosed and it would be included in the Gross Area.

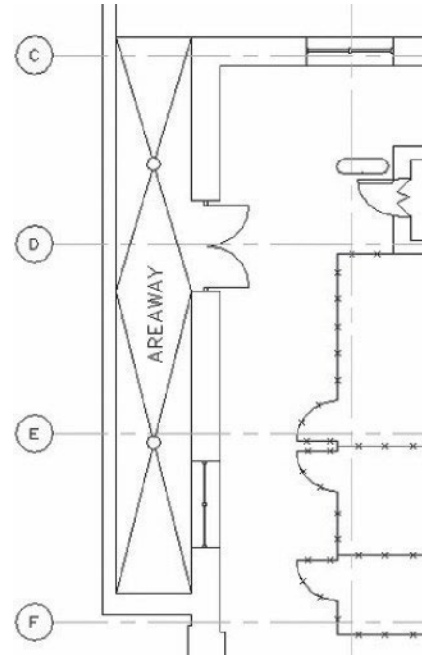

Example of a floor plan showing an areaway.

Initially it may appear the areaway is part of the total constructed area of this building.

However, since the areaway is not enclosed and is open to the sky, it must not be included in the Gross Area.

Atriums, Enclosed Courtyards, Lobbies, and Voids

The following examples give a pictorial view of what these spaces may look like and how these types of spaces can be treated. Other names for these types of spaces include: central hall with skylight, enclosed courtyard, court, quad, large interior patio, quadrangle, open space, or gallery.



Example of a lobby entrance with an atrium.

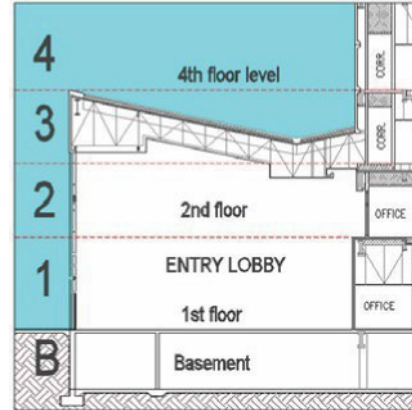

Drawing section of the picture above:

B = Basement
1 = Ground floor entry lobby (CRH)
2 = 2nd floor atrium (OTB)
3 = 3rd floor atrium (OTB)
(B and 1 are included in Gross Area) (2 & 3 are excluded from Gross Area)

4 = Exterior of the building and not included in Gross Area.



Example of an enclosed courtyard. If used by one occupant, the 1st level is assigned TTO, while the 2nd and 3rd floors would be assigned as TFC. If used by all the occupants, the 1st level is assigned CRH, while the 2nd and 3rd floors would be assigned as OTB.



Example of a skylight above an enclosed courtyard.

Atria, Enclosed Courtyards, Lobbies, and Voids (continued)



Example of an entry lobby with atrium, sloped walls, and structural columns. Floors above the lowest-level entry lobby would be measured as if the slab exists and excluded from the Gross calculation.



Example: View looking up through an atrium to skylight. Balconies in this Common area are included in the Gross calculation as CRH because they exist within an enclosed space.

Attic Space and Restricted Head Room

Attic space is usually found in historic buildings with hip roofs. Attic space can be Rentable area if it meets the requirements of a typical office floor.

Note: If attic space is built out as office space (TTO), it must be named OFFICE. If attic space is built out as storage, it must be named STORAGE. Use the room name ATTIC SPACE only when the space is Unmarketable UFO space.



Example of a building that has attic space.



Example of a building that has no attic space. This is a roof with a mechanical penthouse.



Example of attic space.

This attic space has been built out as rentable office space. The tenant space begins where the finished wall meets the sloped wall.



Example of attic space that has been built out as rentable office space. The tenant space begins where the finished wall meets the sloped ceiling.

The doors lead into a space that is actually Unsuitable for Occupancy (UFO). The UFO space goes to the exterior of the building to line up with the Dominant Portion of the floor below.



Example of unfinished attic space. This space is included in the Gross Area.

Illustration C-1: This is an example of a space with restricted headroom. Restricted headroom is less than 7 feet high; more than 7 feet is assignable.

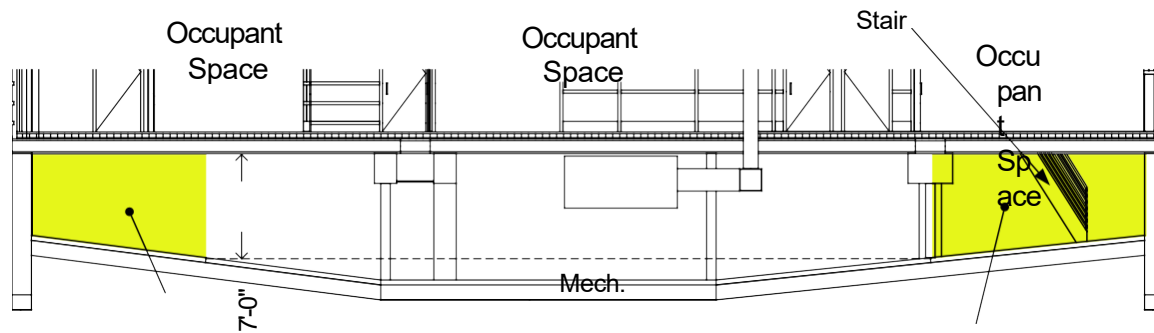

UFO (Unsuitable for occupancy)
Restricted Headroom

UFO (Unsuitable for occupancy)
Restricted Headroom

Illustration C-2: This is an example of a sloping enclosure with restricted headroom. The yellow shaded area is UFO (Unsuitable for Occupancy). The areas that do not have coloring are assignable space.

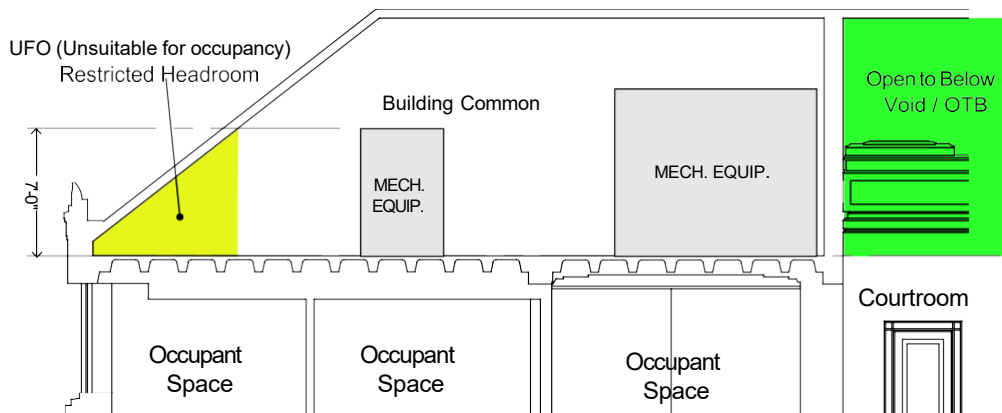

Note: If an occupant can make use of **Unsuitable for Occupancy** space, it cannot be assigned as UFO. In other words, if a space is being used by an occupant or for building support services it cannot be UFO and should be assigned the appropriate Usable classification. When space is less than 7' high *and* is Nonassignable (unusable), then it can be assigned as UFO.

Balconies and Terraces

PBS includes occupant or multiple occupants covered balconies when calculating the Gross Area. They must have a slab or roof above and a slab or foundation below, and they must be within the building line. For exceptions or determinations, contact the Central Office SDM Team.

Balconies are highlighted in grey on floor plans below:

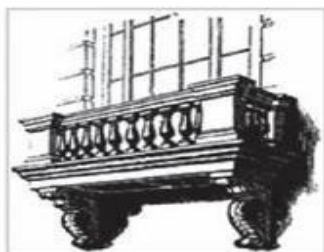
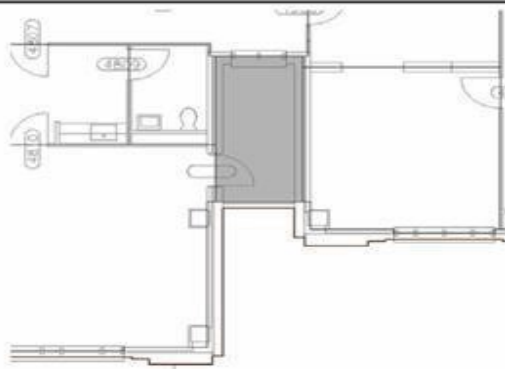
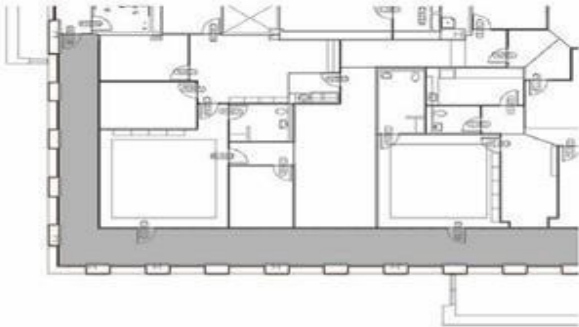

Balconies and Terraces (continued)



Partially covered upper-level terrace used as a Seating area for a Joint Use cafeteria. In this example, the terrace would be included in the Gross Area.



The diagram on the left shows a terrace that is within a tenant's space and was designed and used by one tenant. This terrace would be included in the Gross Area.



An example of covered balconies which would be included in the Gross Area.

Note they have a slab and are covered above.

Colonnades

Colonnades such as the one depicted below are not part of the Gross Area due to the substantial cost to build out.

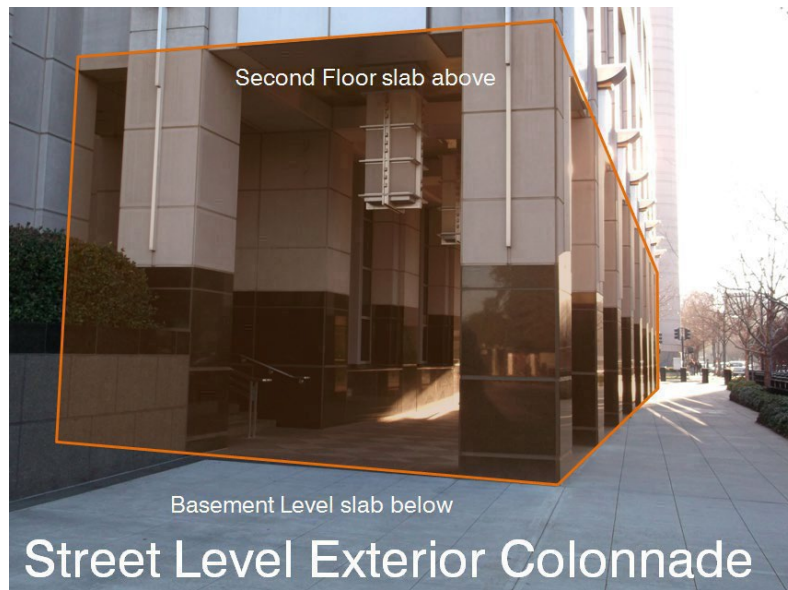

Base Isolation Systems

Base isolation systems are located in the sub-basement or crawl space of a building. Unexcavated crawl space is not included in the Gross Area calculation unless it contains a base isolation system.

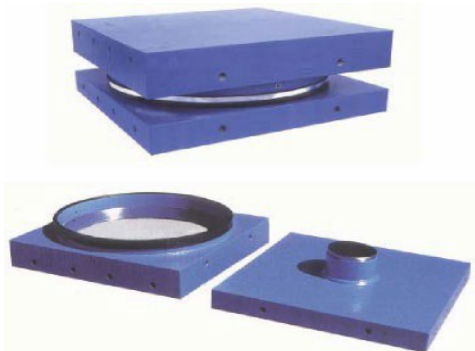

Picture of a base isolation system.

Base isolation is a structural system that literally isolates the base of the foundation from the top or the rest of the buildings with a ball- or socket-type connection made of incredibly high-strength steel and Teflon so it can slide.

Base Isolation Systems (Continued)

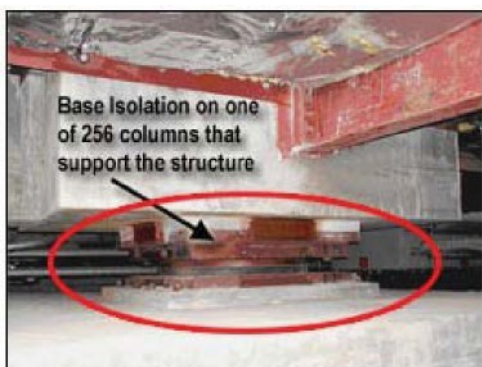

In 1993, the San Francisco Court of Appeals Building was seismically retrofitted to make the building more earthquake-resistant by using an innovative technique called base isolation.

All 256 columns were sliced through, and this connection was inserted. This system allows the building to move as a single unit in an earthquake.



Exterior view of the Pioneer Courthouse being retrofitted with a base isolation system.



Interior view of the base isolation system being installed at the Pioneer Courthouse.

This illustration shows the removal of dirt under the existing building to install the base isolators.

Exterior Structural Bracing and Columns

Many Federal buildings have exterior structural bracing. Sometimes it is part of the building's original design and sometimes it is added later as part of a seismic upgrade.



Example of an older building with exterior structural bracing added to improve earthquake resistance.

The square footage covered by this bracing is not included in the Gross Area.



Example of exterior structural bracing that is part of the building's original design.

The square footage outside the window wall is not included in the Gross Area.

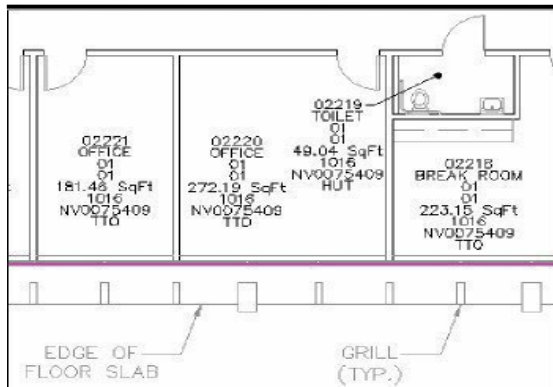

Second floor plan of building above.

The magenta line shows the floor boundary. The floor boundary for the typical floors is located at the window wall, not at the edge of the floor slab, grill, or exterior columns.

Note: The column is not part of the shell wall. It is actually outside the floor boundary line and is not included in the Gross Area.

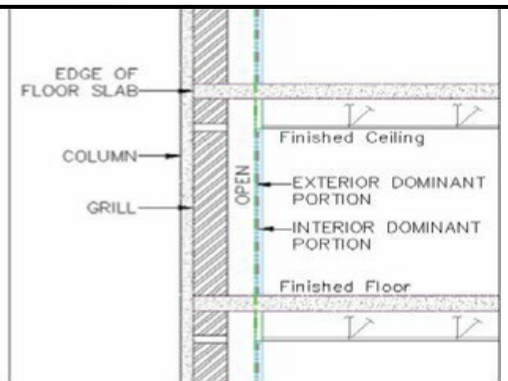

Recessed curtain walls. The curtain wall in the drawing above is termed a "grill." Curtain wall is a type of building facade that has no or structural function.

The floor boundary for the first and second floors is located at the window wall, not at the edge of the floor slabs or exterior structural bracing.

Note: The column is not part of the shell wall. It is actually outside the floor boundary line and is not included in the Gross Area.



Exterior structural bracing. Part of the building's original design acts as a design feature as well as a structural component.

The columns are structural and the lattice work or grill between columns is decorative and not structural.

Façade Elements

Any Federal building can have façade elements that are either part of the building's original design or added later as part of a building renovation.

These façade elements are not included in the Gross Area calculation because they are outside the building line.



Façade element added as part of a building renovation. It is purely a design feature and has no structural importance. Façade elements are not included in the Gross calculation.

Below is the second-floor plan of the building on the left. The magenta line shows the floor boundary.

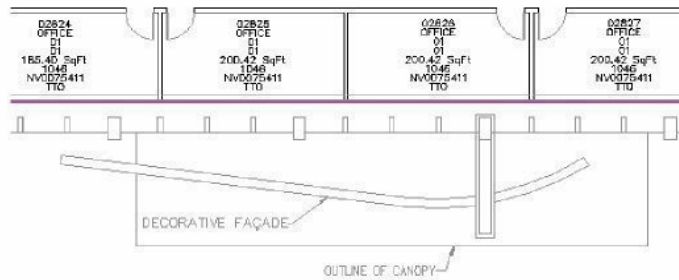

South side of the San Francisco Federal Building sheathed with an undulating, perforated metal screen.

Items such as sunscreens and scrims are not included in the Gross calculation. The floor boundary is defined by the all-glass building wall.



North side of the San Francisco Federal Building. This façade element is not included in the Gross Area.

Chronicle / Kurt Rogers

Skylights and Light Wells

Many Federal buildings have skylights as an architectural element. However, in some buildings, skylights can be a complicated assignment if they occur in space on different levels, raising the question of whether they are tenant floor cuts.

A light well shaft within a building that is open to the outside at the top to allow daylight and fresh air through windows set into the sides of the shaft is not included in the Gross Area calculation when it is open to the sky above. However, when the light well shaft is enclosed by a skylight, it is included in the Gross Area calculation.

Federal buildings can contain a specialized form of light chamber/skylight architectural arrangement in which there is a room (such as a courtroom) which has a skylight in the ceiling that opens to another room above, which is used exclusively to augment or enhance natural sunlight from above or outside. There are also situations in which the skylight is actually on the roof and not in the ceiling. Such spaces are sometimes annotated as a clerestory.



A typical skylight in a courtroom of a historic building. It may appear that this skylight is open to the sky above and is illuminated by natural sunlight.

See photograph to the right for what is actually above this skylight.



A specialized light chamber/skylight sometimes found above a courtroom or any other type of room. This type of space is known as a "light well" or "light chamber".

This room is included in the Gross Area and is assigned to the occupant as TFC.



Clerestory: If a clerestory is penetrating through the roof, it is a Void. This is labeled with text on the construction drawings as clerestory above a special-proceedings courtroom.

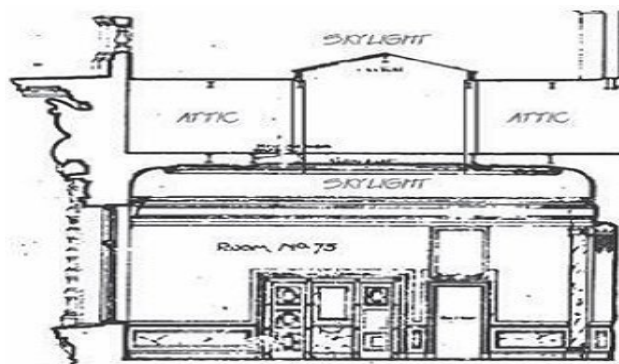

A specialized skylight found above a conference room. The skylight in the ceiling of Room No. 75 receives light from a skylight mounted on the roof of unmarketable attic space and does not penetrate any Rentable area. This enclosed light chamber skylight is not included in Gross Area and would be a Void.

Loading Docks

Receiving areas, such as loading docks within the building line, should be included in the Gross Area calculation. Any part of a loading dock that is outside the building line is excluded from the Gross Area.



The area in front of an enclosed loading dock platform is known as the truck maneuvering area and is assigned with the loading dock space.

Even if there was no roll-up door, this space would be assigned as loading dock because it is within the building line.

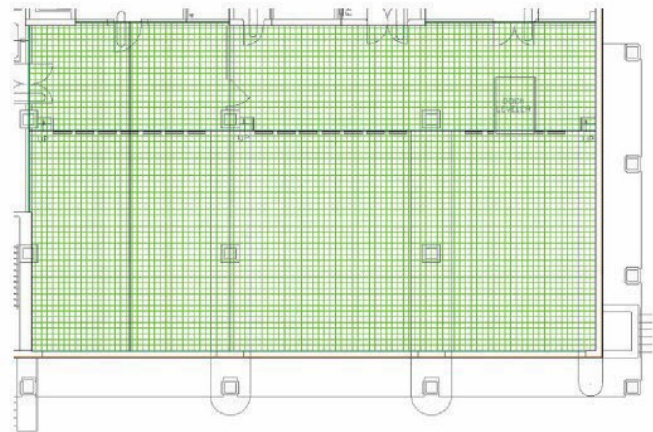
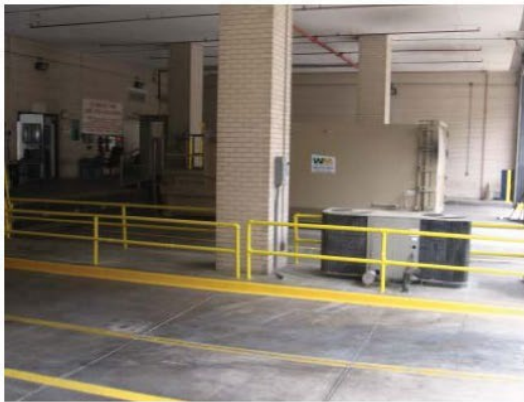

The loading dock pictured below is covered. However, not all of the loading dock is included in the Gross Area of the building. Only the area that falls within the building line is counted as square footage in the building; therefore, the portion under the overhang is not included in the Gross Area of the building.

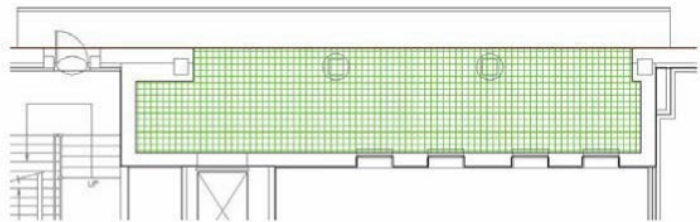
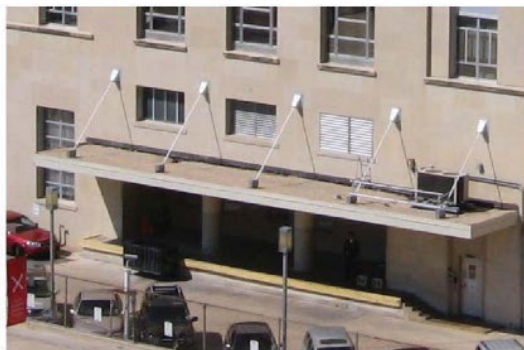

Parking Ramps

Enclosed vehicular ramps leading into parking levels are included in the Gross Area. There may be a roll-up door where the ramp enters the building.

A fully enclosed vehicular ramp leading to or inside Structured Parking that fits the requirements of a vertical penetration is considered a Vertical Penetration and named RAMP.

If an enclosed vehicular RAMP does not go from one level to another level, it is part of the Structured Parking. Sometimes ramps only go a few feet to a slightly higher or lower part of a parking level. In these cases, it is not a full floor height change. Just like a stair, it needs to go from one level to another level to be CRV, not a few feet.

Rooms with Structural Bracing



Example of an exterior parking ramp. On the outside of the roll-up door (photo shown), the unenclosed ramp is not included in the Gross calculation.

These rooms are less-than-ideal spaces, and other times these rooms are adequate for occupancy.

The ANSI/BOMA guidance regarding columns is, "No deduction shall be made for columns and projections necessary to the building." PBS considers structural bracing to be a column or a projection necessary to the building that is included in Gross Area as rentable.



Space with a structural brace. This room meets the requirements of Assignable Space and is assigned as TTO.



Space with a structural brace. This room is basement storage that is built out and is assigned as GNS.

D. Glossary and Acronyms

Amenity	A space that provides comfort, convenience, or pleasure.
ANSI	American National Standards Institute
Area Line	A line segment that divides two adjacent spaces.
Areaway	Small sunken areas that allow access or light and air to basement doors or windows.
Attic	A space immediately below the roof of a building.
Atrium	A public space typically associated with the entrance of a building, usually a monumental architectural glass wall that is often different in design from the body of the building, extends several stories, has skylights or a glass roof, and/or has open balconies on the upper stories to facilitate increasing the amount of natural light into the space—a building trend established around 1985.
BIM	Building Information Modeling
BOMA	Building Owners and Managers Association International
Building Common Area	Areas that provide services or circulation to all building occupants.
Building Line	The exterior surface of the building that provides (full or partial) enclosure with a slab or roof immediately above and a slab or foundation immediately below.
CAD	Computer Aided Design
CAFM	Computer Aided Facility Management
Circulation	The areas on a floor necessary for access to egress stairs, elevator lobbies, public toilets, refuse area, building lobbies, and entrances. It is based on the actual layout of a floor and may vary over time or as space configurations change, and from floor to floor depending on the number of occupants on a floor.
Clerestory	A clerestory is an upper portion of a wall containing windows for supplying natural light to a building.
Closed Polygon	A polygon is a two-dimensional shape that is bounded by a closed path and composed of a finite sequence of straight- and curved-line segments. These segments are called “edges,” and the points where two edges meet are the polygon’s “vertices” (singular: vertex). A polygon’s area determines the Usable SF, which is the basis for the rent bill.
Common Area	Common area is defined as the area(s) of the building that provide services, support, or horizontal circulation to building occupants.
Community	A group of Federal buildings within a specific geographic area.
Community Joint Use	Amenities such as childcare centers or cafeterias housed in one building and available to occupant agencies in neighboring buildings.
Construction Area	The thickness of the outside wall measured from the interior dominant vertical portion to the exterior dominant vertical portion of the building.

Crawl Space	Horizontal access space: a low unfinished space under a floor or above a ceiling in a building that gives access to plumbing, wiring, and ductwork.
Dominant Portion	ANSI/BOMA defines it as the portion of the inside, finished surface of the permanent, outer, building wall, which is 50% or more of the vertical floor-to-ceiling dimension at the given point being measured as one moves horizontally along the wall.
Excluded from Gross	Space category associated with Space Class Open to Below (OTB) or Voids
External Circulation	Typically found in warm climates, these are partially enclosed walkways which function as multi-occupant corridors only when there is no fully enclosed means to provide access to or egress from the offices or wing of a building. Refer to ANSI-BOMA 2010 for more complete description and examples.
Finished Surfaces	A wall, ceiling, floor, or surface, including glass, as prepared for occupant use, excluding the thickness of any special surfacing materials such as paneling, furring strips, and/or carpet.
Floor Boundary	An enclosed area that defines a floor.
Floor Common Area	Areas that provide services or circulation to occupants on that floor.
Floor Plan	An electronic or paper drawing of a horizontal section of a building at a given level.
Fully Enclosed	A space with four walls, a ceiling, and floor that is protected from outside elements. Also known as “Enclosed.”
Gross Area	This is the total floor area contained within the measure line, generally the outside surface of the exterior enclosure of a building. In other words, it is the total constructed area of a building; it is the sum of all spaces on all floors of a building measured to the exterior enclosing walls.
Gross Measured Area	All spaces within the interior dominant portion of the building minus from Construction space.
GSA	General Services Administration
Hip Roof	A roof with sloping ends or sides.
Interstitial Space	An intermediate space located between regular-use floors.
Joint Use Space	Shared amenities in a building available for use by all occupants of that building or facility.
Judge’s Chambers Suite	Included in the chamber’s suite are the judge’s private office, conference room, corridors, reception, office, closets, private toilet, judges’ libraries, law clerk offices (when part of the judge’s chambers), service unit, and secretarial area.
LEED	Leadership in Energy and Environmental Design (LEED) is a rating system devised by the United States Green Building Council (USGBC) to evaluate the environmental performance of a building and encourage market transformation towards sustainable design.
Lobby	Space used as an entranceway or foyer in a building.
Mezzanine	An intermediate or partial floor between two main floors of a building, it often projects in the form of a balcony, corridor, or similar feature.

Nonassignable Space	Unmarketable, measured areas within a building.
Occupant	Interchangeable with Tenant, the person or persons who occupy and use the space in either federally owned or leased buildings.
Partial Floor	A feature commonly associated with atriums or voids, it refers to space in a floor that is missing, where a floor would be expected due to empty space created by an atrium or void.
PBS	Public Buildings Service
PBS Specific	A space category PBS has devised for addressing Unmarketable areas of a building.
PMO	Property Management Office
Portfolio Lease	The Pricing Desk Guide defines this as a type of rental contract in which the leased space is priced as federally owned space using fair annual rent appraisals. (Link to the Pricing Desk Guide is in References section of this document.)
Rentable Area	The total amount of space an occupant can occupy or use within a building and the respective share of Common Area related to the Usable area.
RPAM	Real Property Asset Management
SDM	Spatial Data Management
Service Area	Areas of a building that provide services (mechanical and equipment rooms, lobbies, building storage, etc.) that enables occupants to work in a building. Without service areas, it is impossible to accommodate occupants within a building without violating existing building codes and/or occupancy controls.
Service Unit	A service unit has upper and lower cabinets, a refrigerator without water or an ice maker, sink with disposal, and a microwave.
Shell	Due to length of definition, refer to the PBS Pricing Desk Guide for definition of shell. (Link to the Pricing Desk Guide in References section of this document.)
Skylight	An overhead window, usually on a roof, that admits daylight.
Space Boundary	A sequence of straight and or curved line segments creating a Closed Polygon. Space Boundaries are a standard component of most CAD software programs, as well as a basic concept of real estate space assignment.
Special Space	This term is found various places, such as the Standard Form 81 (SF-81), Request for Space form. It refers to space that has unique architectural/construction features, requires the installation of special equipment or requires varying sums to construct, maintain and/or operate as compared to office and storage areas. SDM defines all the spaces encompassed by the term through the use of specific Space Class defined in this document.
Substantial Completion	“Substantial completion” and “substantially complete” mean that the work, in the common and other areas of the building, and all other things necessary for the Government’s access to the premises and occupancy, possession, use and enjoyment thereof, have been completed or obtained, excepting only such minor matters as do not interfere with or materially diminish such access, occupancy, possession, use or enjoyment. (Excerpt from the General Services Administration Acquisition Manual (GSAM)).

Tenant Floor Cut	An opening in a floor above an occupant's finished floor designed for or used by a specific occupant, such as an upper level of a double-height courtroom. The floor cut eliminates otherwise Usable space. BOMA defines a tenant floor cut as an occupant void.
Unexcavated Space	Space that has not been constructed or built-out for occupant use.
Unmarketable Space	Space that cannot be marketed to building occupants.
Unsuitable for Occupancy	Space in a building that cannot be used for or easily converted to Usable Space. Assigned due to spaces with conditions like low ceiling height, structural damage and/or hazardous conditions.
Usable Area	Spaces in a building that can be assigned to a specific occupant (Assignable Space) plus amenity areas (Joint Use Space). It includes the wall hierarchy as explained in this policy under Space Boundaries section.
Vending	Spaces where food and drink can be found for sale. The space may also include small seating area.
Vertical Penetrations	Openings that penetrate the slabs between floors for the use of supporting stairs, elevators, flues, pipes, and ducts, and it must be 9 square feet or greater.
Void	<p>Per ANSI/BOMA: "Absence of a floor within the exterior enclosure of a building in excess of 10 square feet (GSA-PBS uses 9 square feet or greater) where a floor might otherwise be expected or measured, that is typically in the plane of the upper floors adjacent to the following Nonassignable spaces: multi-story atria or lobbies, light wells, auditoria or the area adjacent to a partial floor, permanent mezzanine, or unclassified mezzanine at a given floor level. Voids are distinguished from major vertical penetrations as defined in ANSI/BOMA Z65.1-2010 in the following ways:</p> <ol style="list-style-type: none"> 1. Major vertical penetrations have a functional purpose, such as allowing passage of building services (HVAC ducts, flues, chutes, dumb-waiters, plumbing, electrical, etc.) or building access and egress (stairs, escalators, elevators, etc.), whereas voids only accommodate the need for certain spaces to be higher than adjacent floors. 2. Major vertical penetrations are included in construction Gross Area and exterior Gross Area, whereas voids are excluded; and 3. The areas of major vertical penetrations include their enclosing walls, whereas the areas of voids exclude their enclosing walls. If there is no enclosing wall between a void and an adjacent floor, the area of the void extends to the edge of such adjacent floor."
Wellness Rooms	Spaces dedicated to the health and well-being of occupants in a building.

E. Calculations

This section contains all calculations contained throughout the document. Refer to Diagram 1: PBS Space Assignment Diagram, for further information.

- $\text{Gross Area} = \text{Rentable Area} + \text{Nonassignable space} - \text{Open to Below (Void)}$
- $\text{Gross Measured Area} = \text{Gross Area} - \text{Construction}$
- $\text{Usable Area} = \text{Assignable space} + \text{Joint Use space}$
- $\text{Rentable Area} = \text{Common area} + \text{Usable area}$
- $\text{Rentable Area} = \text{Usable area} \times \text{Building R/U Factor (Load Factor)}$
- $\text{01-Office Area} = \text{Assignable space} + \text{Joint Use space}$
- $\text{Building R/U Factor (Load Factor)} = \text{Rentable Area} \div \text{Usable Area}$
- $\text{Nonassignable Space} = \text{Gross Area} - \text{Rentable Area} + \text{Open to Below (Void)}$

F. Assignment Maintenance and Building Churn

After an IMV the building enters the GSA SDM inventory and moves into the maintenance phase. See [History and Evolution of SDM](#) and [Measurement Guidance](#) in this document for more information and note the following:

- Projects that include rearranging walls and changing the floor plan should be reviewed by the SDM team as early in the project as possible.
- Major remodels should be reviewed by SDM in the Design Phase to ensure NBSAP compliance and provide correct area calculations for Draft OAs.
- Often new designs will alter the R/U of a building by changing the amount of Common space.
- Assignment problems often occur when a design converts Common and Public space to Usable area, and vice versa.
- Common areas and Public vertical circulation spaces are fixed in a building and should not change constantly.
- Common types of space are not equal, nor should they be treated equally.
- Space should not move back and forth from Tenant to Shell. A certain amount of Shell space is needed for operational efficiency.

The table below provides assignment assistance; however, it is in the nature of office design and building maintenance to encounter problematic architectural situations which have to be resolved according to the projects and tenant's operational requirements.

Space Class	Description	Can be landlocked by Usable	Occupant can enter	Notes
CRH	Circulation Horizontal	Very rare	Yes	This can change as the layout of floor changes. Changing assignable space to CRH (and vice versa) is not really difficult.
CST	Custodial & some Property Management Offices (PMO)	Yes, sometimes	No	Custodial space generally does not change unless there is a substantial reconfiguration. Changing assignable space to CST is not easy. PMO assigned 4762 is Usable space and easy to convert to tenant space.
MCH	Mechanical & BLDG Security	Yes, frequently	No	Unless there is a reconfiguration of space/walls creating a new floor layout mechanical room usually do not change. Considered a cost prohibitive design option. Mechanical space generally does not change. Changing assignable space to MCH is not easy.
TLT	Toilets (Shell)	Yes	Yes	A certain number of "floor common shell restrooms" are provided on every floor, just as a certain number of "building common shell restrooms" are provided in every federal building. Those shell restrooms remain Common even if they become landlocked by a tenant. Changing assignable space to TLT, and or vice versa, is not easy.
CRV	Circulation Vertical	Yes, frequently	Yes	Public elevators and public stairs should never change. Changing public CRV to private TFC is difficult and might be impossible due to shell and core requirements.

G. Assign Space by Build Out Clarification

The first thing you need to think about when assigning space is not Space Type, but Space Classification in terms of being **Base Building Support** or **Base Building Usable**.

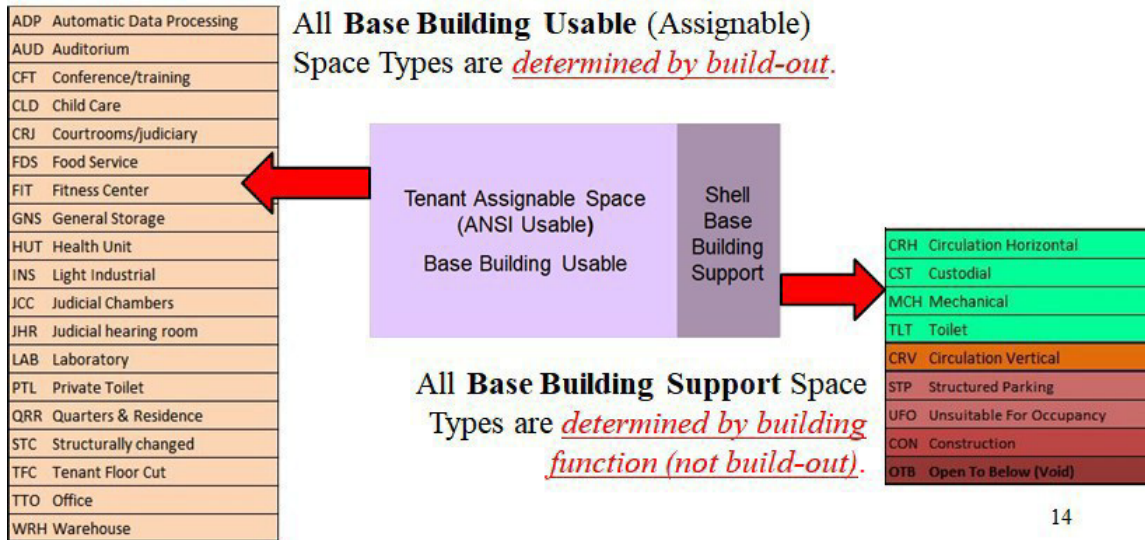

H. Old Room Name Crosswalk with Omniclass

NBSAP ROOM NAME	NBSAP Room Name Definition	Omniclass Room Name	Omniclass Room Name Definition	Condition
AQUARIUM	Space for the public exhibition of live, aquatic animals and plants for exhibit, study, and/or display. The associated rooms for the aquarium, such as a separate room for aquarium equipment or machinery, would also be named "Aquarium".	AQUARIUM	A tank, containing or filled with water, generally used to detain a fish or marine animal.	
ATM	Automatic Teller Machine. If there is a separate room for customer access to the ATM, that room must be named ATM. If an ATM is in a lobby or corridor, no square footage (or area) is assigned to the ATM on the customer side. The room behind the ATM that is used to house ATM equipment is also named ATM. The ATM equipment space needs to be greater than 9 square feet (measured to inside wall face) to be counted.	Automatic Teller Machine Space	Area associated with a wall mounted banking machine and space for the user to access the machine	
ATRIUM	Multi-story, enclosed space in a building that has access to natural light. The upper floors of the atrium must be named ATRIUM except the lowest floor, which must be named LOBBY.	Light Well	Multi-story, enclosed space in a building, which may have a skylight. Every level of the atrium	
ATTIC SPACE	Space can have sloped or low ceilings, with no elevator access to the floor. Generally consists of unfinished floors, walls, and ceilings. Space boundary line for sloping ceilings in an attic is located where there is 7 feet or less of headroom. Use the room name ATTIC SPACE only when the space is Unmarketable, UFO space.	Attic Space	The space between the ceiling beams of the top story and the roof rafters.	
AUDITORIUM	Stages, audience seating areas, and platforms must be named auditoriums. Auditoriums have structurally changed floors and/or ceilings. These spaces generally have above-standard air conditioning and are larger than 400 square feet. Upper parts of auditorium are also named AUDITORIUM (in the same way as a set of stairs is named STAIR on every level).	Performance Hall	A room or theater, often with tiers of seats, which serves as performance venue, such as for classical instrumental music or jazz, or for hearing lectures or presentations. Includes amphitheaters, auditoriums, or concert halls.	
AVIARY	Space where birds or fowl are kept for inspection, quarantine or treatment purposes. Typically found in a Port of Entry.	Cage	A typically small, freestanding, wire enclosed space for detaining an animal or bird	
BALCONY	A platform that projects from the wall of a building and is enclosed by a parapet or railing, or it is an interior projecting gallery in a public building (such as a theater). Use this room name only with SDM coordinator approval.	Balcony	A horizontal extension of an adjacent floor outside the exterior enclosure of a building that is not a roof.	
BARBER SHOP	Space used by barber or hair stylist to conduct their business.	Haircutting Space	Space used by barber or hairdresser to conduct said business.	
BOX LOBBY	Lobby with post office-type boxes. Usually assigned to U.S. Postal Service.	Box Lobby	Lobby with post office-type boxes. Usually assigned to U.S. Postal Service.	

NBSAP ROOM NAME	NBSAP Room Name Definition	Omniclass Room Name	Omniclass Room Name Definition	Condition
BREAK	Room or area used by employees during break times. This may include a service unit and can also contain miscellaneous storage, localized mail stop facilities, and other miscellaneous office amenities.	Coffee stations	Room or area used by employees during break times. This may include a service unit and can BREAK also contain miscellaneous storage, localized mail stop facilities, and other miscellaneous office amenities.	
CAFETERIA	Restaurant in which the customers serve themselves or are served at a counter and take the food to tables. Usually contains serving and seating area.	Cafeteria Vending Space	Space in a cafeteria or dining hall in which customers select their food at a counter.	
CANOPY	Structure that covers something, sometimes attached to a building. Use this room name only with SDM coordinator approval.	Canopy	An overhead roof or structure that is able to provide shade or shelter.	
CHILD CARE	Area specifically used for childcare or day care, located in Federally owned or leased property. Includes open activity area, activity area for infants, toddlers, preschoolers, and school-aged children. Also included are diapering stations and sleeping/napping areas. Note: Spaces within a Child Care are classified by build-out, but all receive the room name Child Care for query purposes.	Child Day Care Space	A space for the daytime supervision of children.	
CLASSROOM	Rooms used for instruction, with supplemental HVAC and/or built-in special equipment such as blackout curtains, lighting controls, projection booths, and sound conditioning, in addition to office furnishings like desks and chairs. Note the difference between a classroom and a training room is the training room has no special build-out.	Training Spaces	Space that is similar in configuration to a classroom, but which contains specialized equipment or machinery used as part of a specific training activity.	
CLOSET	Small room used for containment of work-related items.	Closet	Small room used for containment of work-related items.	
COMPUTER	Room used for computers, servers, and their related electronic functions and activities.	Computer Server Room	Climate controlled space for servers associated with office environments	
CONFERENCE	Any office room used primarily as a conference room by a single occupant. There are certain qualifications a room must meet to receive the Space Class CFT (Conference/Training). A room that is named and used as a conference room does not necessarily mean it has a Space Class CFT.	Conference Room	Any office room used primarily as a conference room by a single tenant	
CONSTRUCTION	Thickness of the outside shell wall, measured from the interior Dominant Portion (vertical) to the exterior finished surface of the building.	Exterior Wall Space	The space of a wall that divides/separates inside spaces from outside spaces. The wall may be structural or non-structural	
CONTROL BOOTH	Booth not covered by a canopy that is used to control vehicular and pedestrian access at a Land Port of Entry (LPOE) property only.	Exterior Parking Access Control Point	Outdoor parking access control point space such as attendant booth, gate, card reader, or self-serve ticket dispenser.	
COPY	Room used exclusively or primarily for photocopy machines. Room can also contain files, storage,	Printing and Reproduction	Space for the reproduction and distribution of documents.	

NBSAP ROOM NAME	NBSAP Room Name Definition	Omniclass Room Name	Omniclass Room Name Definition	Condition
	supplies, and other typical office items. Predominate use of room must be to photocopy.	Spaces		
CORR.	Corridor. Passageway into which rooms and other corridors open.	Corridor	An enclosed exit access component that defines and provides a path of egress travel to an exit.	
COURTROOM	Room in which a court of law is held. Room needs the appropriate build-out to be named COURTROOM.	Courtroom	The room where a judge presides over hearings and trials, sometimes with a jury	
CRAWL SPACE	Horizontal access space in a building that is either minimally finished or unfinished and gives access to plumbing, wiring, ductwork, or base isolation systems.	Crawl Space	Unexcavated space that has restricted headroom and is not occupiable.	
CREDIT UNION	Enterprise that offers banking services. The room name CREDIT UNION should be applied to the open area in front of the teller counter. All other rooms in a credit union suite receive room names determined by use.	Banking Spaces	Space specific to banking such as teller spaces, vaults, safety deposit space and automated teller machines.	
CUST.	Custodial Room that contains a one or more standard sink or mop sink and is used by custodial services for their related activities. A janitorial storage room would have the room name STORAGE and Space Class CST, not room name CUST.	Custodial Space	Room that contains sink(s) or mop sink(s) and is used by custodial services for CUST. their related activities.	
DUMBWAITER	Small elevator or transportation device used to move goods vertically between floors of a building.	Dumbwaiter	A small lift / elevator used to move food etc. from one floor of a building to another.	
ELEC.	Electrical Room used to house electrical equipment, panels, and/or meters.	Electrical Room	A designated room containing electrical equipment.	
ELEV. LOBBY	Elevator Lobby. Waiting area for elevators.	Elevator Lobby	Lobby that separates the elevator shaft enclosure doors from each floor by fire partitions.	
ELEV. PIT	Elevator Pit. Space at the bottom of an elevator shaft.	Elevator Pit		
ELEV. VEST.	Elevator Vestibule. Small room or hall in front of elevators.	Elevator Lobby	Lobby that separates the elevator shaft enclosure doors from each floor by fire partitions.	
ELEVATOR(S)	Platform or an enclosure raised and lowered in a vertical shaft used primarily to transport people.	Elevator Cab	Platform or an enclosure raised and lowered in a vertical shaft to transport people or freight.	
ENTRY LOBBY	A large entrance area or hall that serves as a foyer.	Entry Lobby	A large entrance area of hall that serves as a foyer	
ENTRY VEST.	Entry Vestibule. An enclosed entrance between the outer door and the interior of a building.	Entry Vestibule	A passage, hall or room between the outer door and the interior of a building	
EQUIP. RM.	Equipment Room. Audio/Visual equipment rooms associated with conference rooms, courtrooms, and auditoriums. Room used to house radio equipment and/or conduct associated activities. Not to be used as building support mechanical rooms. Rooms housing machinery for courtroom lifts are named MECH.	Meeting Equipment Room	Audio/Visual equipment rooms associated with conference rooms, courtrooms, and auditoriums. Room used to house radio equipment and/or conduct associated activities.	
ESCALATOR	Set of moving steps attached to a continuously circulating belt that carries people up or down between levels in a building.	Escalator	Set of moving steps attached to a continuously circulating belt that carries people up or down between levels in a building.	
EVIDENCE	Room used to secure legal evidence, usually near a courtroom.	Evidence Room	Room used to secure legal evidence, usually near a courtroom.	
EXAM	Medical Examination Room. Room used by medical personnel to determine health or condition.	Exam Room	Space used for routine, urgent, and emergent examination (physical inspection of a patient or	

NBSAP ROOM NAME	NBSAP Room Name Definition	Omniclass Room Name	Omniclass Room Name Definition	Condition
			parts of his body) in order to verify health or diagnose disease or injury. May also be Space used for minor procedures such as injections, wound care, and suturing.	
EXERCISE RM.	Exercise Room. Room used for physical wellness but does not include improvements to accommodate weight-lifting equipment.	Exercise Room	Space used for physical wellness but does not include weight-lifting equipment	
FILE	Room used primarily for hardcopy files. Room can also contain storage, supplies, and other typical office items. Predominant use of room must be to house hardcopy files.	Filing Space	Space for filing cabinets and storage of paper materials	
FIRING RANGE	Enclosed space specifically designed for firearms practice, including the testing and certifying of staff required to carry firearms.	Indoor Firing Range	Indoor firing ranges provide marksmanship training space for the firing of pistols and small caliber rifles.	
FPS CONTROL ROOM	Room where the Fire Protection System (FPS) Control system is located.	Fire Command Center	Space for fire department operations with the location, layout, content and features and approved by the fire department; includes Fire Protection System (FPS)	
FRT. ELEV.	Freight Elevator. Device for vertical transportation of freight to different floors or levels in a building.	Freight Elevator	Device for vertical transportation of freight to different floors or levels in a building	
FRT. ELEV. VEST.	Freight Elevator Vestibule. Small room or hall in front of freight elevators.	Freight Elevator Vestibule	A small passage, hall, or room between a door or room and a freight elevator.	
FULL SERV. CNTR.	Full-Service Center. Specific to the U.S. Postal Service (USPS). Post office space that provides all the services made available by the USPS.	Post Office Space	Specialized space in a facility that houses United States Postal Service operations.	
FUR.	Furring. Furred-out space is created when the floor layout must accommodate irregular wall surfaces or conceal mechanical obstructions (e.g., piping and electrical conduits). Furred-out spaces usually have no access but from a space assignment position are absorbed by and assigned the Space Class of the adjacent spaces, if less than 9 square feet. Spaces over 9 square feet must be assigned like any other space. Furred spaces greater than 9 square feet (measured to inside wall face) that accommodate mechanical equipment (such as a pipe enclosure) must be assigned Space Class MCH (Mechanical) and receive room name MECH.	Furred Space	Furred-out space is created when the floor layout must accommodate irregular wall surfaces or conceal mechanical obstructions.	
GARAGE	Shelter or repair shop for vehicles. Also includes enclosed inspection bays for vehicles. Space Class is typically STP (Structured Parking).	Interior Vehicle Service Space	Interior parking stall and circulation space used to provide vehicle services.	
GUARD STATION	Booth or room within the building line used to house security personnel for the building or occupant.	Guard Stations	Booth or room within building line used to house security for building or tenant.	
HAZ. MAT. FCTY. CANOPY	Hazardous Material Facility Canopy. Canopy which covers the hazardous material inspection facility at a LPOE only.	Hazardous Waste Canopy	An overhead roof or structure that is able to provide shade or shelter over an area used for the inspection of hazardous materials.	

NBSAP ROOM NAME	NBSAP Room Name Definition	Omniclass Room Name	Omniclass Room Name Definition	Condition
HEARING	Hearing Room used by courts as the location to which evidence is taken for the purpose of determining an issue of fact.	Hearing Room	Room used by courts and administrative agencies as a location where evidence and testimony is submitted for findings of fact. May be closed or open.	
HLDG.	Holding Room or Cell. Space used to detain persons suspected of violating laws. Includes associated chase for plumbing.	Holding Cell	An enclosed floor space use to confine a person(s) of interest for a very short period of time in a particular place	
HUB RM.	Hub Room. Space used as a computer hub room. Contains server and/or electronic equipment racks.	Data Center	Space designed to accommodate the needs of large quantities of co-located computer equipment.	
HUB/TELE.	Hub/Telephone. Room is a combined computer hub room and telephone equipment room.	Data Center	Space designed to accommodate the needs of large quantities of co-located computer equipment.	
IMPOUND LOT	Area where impounded items such as vehicles are stored. Use this room name only with SDM coordinator approval.	Impound Lot	An area used to secure vehicles from general access of the public	
INSPECTION BOOTH	A small, typically stand-alone booth or similar structure used to perform inspections or monitoring.	Inspection Booth	Free-standing booth or structure used to house vehicular traffic inspection personnel.	
INTERVIEW	Room in which interviews are conducted.	Meeting Spaces	Space specifically designed for groups of people to interact on a occasional basis having appropriate seating and other amenities to support this activity.	
JUDGES CHAMBER	A judge's private office. Usually this name is used only in court spaces.	Judges Chambers	The office of a judge.	
JURY ASSEMBLY	Room where prospective jurors gather to wait or assemble before being selected for jury duty. Includes seating area and may include TV, workstations, and tables. Break area or room within jury assembly must be assigned BREAK.	Jury Assembly Space	Room where prospective jurors gather to wait or assemble before being selected for jury duty. Includes seating area and may include TV, workstations, and tables.	
JURY ROOM	Room where jury deliberates to reach a verdict.	Jury Room	The room where a jury is sequestered and deliberates at the close of a trial.	
KENNEL	Facilities (enclosed rooms) provided for the boarding, veterinary care, and/or training of animals.	Kenel	An enclosed, typically permanent, floor space generally used to detain a dog or cat	
KITCHEN	Room used to prepare food in a cafeteria or residence (a microwave oven and refrigerator alone do not make a space a "kitchen").	Kitchen	A room or part of a room used for cooking and food preparation.	
LAB.	Laboratory. Space equipped for experimental study in a science, or space for testing and analysis.	Laboratory Spaces	Space that has built-in equipment, plumbing, and/or utilities for the qualitative and/or quantitative analysis of matter, experimentation, or the processing of materials, including wet and clean laboratories.	
LACTATION ROOM	Lactation Room. A private room for nursing mothers. Space must be private, clean and include a shelf/table and a seat. Often times they include other provisions, such as electrical outlets, refrigerator, etc. It is assigned as Joint Use when available to all nursing mothers in the building.	Lactation Room	Private room for nursing mothers, typically including a refrigerator, sink, cleaning supplies, table and comfortable chair	

NBSAP ROOM NAME	NBSAP Room Name Definition	Omniclass Room Name	Omniclass Room Name Definition	Condition
LAW CLERK	<p>Law Clerk Office – Individual office for each law clerk. Alternatively, clerks can be provided with semi-private workstations in alcoves or separated by modular partitions, bookcases, etc., based on the judge's preference.</p> <p>*Use Space Class JCC if the law clerk office is within the Judicial Chambers, if not within the envelope of the judge's chambers or suite use TTO. This name is usually used only in court spaces.</p>	Law Clerk Space	Space for a law clerk that assists a judge.	
LIBRARY	Space in which literary, musical, artistic, or reference materials (as books, manuscripts, recordings, or films) are kept for use but not for sale.	Library	Space in which literary, musical, artistic, or reference materials (as books, manuscripts, recordings, or films) are kept for use but not for sale.	
LOADING DOCK	Architectural structure designed for efficient loading and unloading of trucks.	Loading Dock	A secondary building entrance space used to accommodate shipping and delivery of bulk materials to the structure.	
LOBBY	Entranceway or foyer within the building line.	Lobby	Entranceway or foyer within the building line.	
LOCKERS	Room containing lockers or small lockable cupboards or compartments in which people secure possessions.	Locker Room	Room containing lockers or small lockable cupboards or compartments in which people secure possessions.	
LOG	Lookout Gallery. Space used to observe employees in work areas performing work-related functions. Typically used by USPS. This includes the ladder rooms to access the lookout gallery.	Lookout Gallery	Space used to observe employees in work areas performing work-related functions. This includes the ladder rooms to access the lookout gallery.	
MAIL RM.	Mail Room. Space in which activities related to handling incoming and outgoing mail occur. If one occupant requests and uses the mailroom, it must be assigned to the occupant. It is assigned as Joint Use space when the mail room is used by all occupants.	Mail Room Space	Mail sorting and distribution space including remote mail stops on floors.	
MECH.	Mechanical. HVAC, plumbing, and/or elevator machinery, and any combination of these items. Rooms that accommodate a small amount of machinery are usually named MECH. Pipe enclosures lacking a vertical penetration that are 9 square feet or greater (measured to inside wall face) also are labeled MECH. if not associated with another room.	Utility Equipment Room	Space provided for the general operation of heating, ventilating, and air conditioning, plumbing and electrical, life safety and communication services; including sections of tunnels which are dedicated to distribution of utilities.	
MEN	Toilets used exclusively by men.	Mens Restroom	Toilet(s) used exclusively by men.	
MONITOR RM.	Monitor Room. Space that houses the consoles for the building automation or mechanical systems. Building Common monitor rooms are assigned the Space Class MCH. Space that houses monitoring equipment involving Guards and Security can use this room name also, if the space is used for these security-related services.	Control Room	Space used for the control and monitoring of life safety and communication services.	

NBSAP ROOM NAME	NBSAP Room Name Definition	Omniclass Room Name	Omniclass Room Name Definition	Condition
NEWS RM.	News Room. Room used by media. Typically assigned to an occupant agency, not Building common.	Press Conference Room	A room to accommodate a media event in which newsmakers invite journalists to hear them speak and, most often, ask questions; this room often includes a podium, seating for the press, and audio-visual, communications, power, and lighting enhancements to accommodate the work of broadcast journalists.	
OFFICE	Room that houses personnel and/or furniture in which occupant conducts business (as compared to a room in which multiple occupants conduct business, which is an OPEN OFFICE).	Office Spaces	Space in which business, clerical or professional activities are conducted.	
OPEN OFFICE	Large, general, office space. An area that houses personnel and/or furniture and the space is open to an adjacent corridor. Typically an OPEN OFFICE contains system furniture. The egress or contiguous corridors through an open office are included in the OPEN OFFICE space and not separated.	Office Spaces	Space in which business, clerical or professional activities are conducted.	
OPEN TO BELOW	This room name applies only to areas or space where there is an absence of a floor within a building where a floor might otherwise be expected or measured, with no access to natural light.	Void Areas	A space inside the building where floor structure might otherwise be expected. The lowest floor of a multi-story void is classified based on the utilization at that level.	Where Space Class Does Not Equal TFC
		Occupant Void Area	Opening in a floor created for the specific benefit of an occupant.	Where Space Class = TFC
OUTBOUND INSP. CANOPY	Outbound Inspection Canopy. Canopy over outbound inspection booths only at a LPOE.	Primary Inspection Canopy	An overhead roof or structure that is able to provide shade or shelter over an area utilized by vehicular traffic inspection personnel.	
PARKING	Space in which to park vehicles, as at a place of business. Enclosed parking includes enclosed roadways on parking levels as well as stalls and pedestrian walkways.	Parking Spaces	Spaces used to circulate and station vehicles.	
PEDESTRIAN PROCESSING	Pedestrian processing encompasses both the pedestrian primary and pedestrian secondary inspection areas. The pedestrian primary inspection is for processing pedestrian traffic entering the U.S. Pedestrian secondary inspection areas are where a more thorough inspection of pedestrians and their belongings is performed.	Pedestrian Processing	Primary or secondary inspection areas for processing pedestrian traffic entering the country.	
PEDESTRIAN WALKWAY	The pedestrian walkway is typically inside the headhouse or administration building to process pedestrian traffic entering the United States. Includes the pedestrian inspection areas. Term is used only for a LPOE.	Pedestrian Walkway	Waiting area for pedestrian traffic entering the country, located prior to entering pedestrian processing areas.	
PRE PRIMARY	The pre-primary area is located in front of the primary inspection booth(s). This is the area of the LPOE that provides vehicular access from a foreign country.	Pre-Primary Inspection	Waiting area for vehicular traffic entering the country, located prior to entering primary inspection booths.	
PRIMARY CANOPY	This canopy covers the main entry area for border crossings and is similar to toll booth canopies. Term is	Primary Canopy	An overhead roof or structure that is able to provide shade or shelter over the main vehicular	

NBSAP ROOM NAME	NBSAP Room Name Definition	Omniclass Room Name	Omniclass Room Name Definition	Condition
	used only at a LPOE.		entry point.	
PRINT RM.	Print Room. Room in which document printing or plotting occurs.	Printing and Reproduction Spaces	Space for the reproduction and distribution of documents.	
PROP. MGR. OFFICE	Property Manager's Office. Space for the property manager.	Building Manager Office	Space for the property manager	
RECEPTION	Room or area where receptionist is located.	Reception Space	A waiting area, such as a lobby or front office desk of an organization or business.	
RESIDENCE	Rooms used as living space by an occupant and may include living room, bedroom, study, dining room, bathroom, and kitchen.	Private Residential Spaces	Space used to provide accommodation for people when not at work. The accommodation provides facilities for sleeping and relaxation and usually cooking, eating, cleaning,	
RETAIL	Space or room including window display spaces, used by retail store.	Sales Spaces	Space where customers or clients can view or purchase product.	
ROBING	Robing Room is an area usually adjacent to a courtroom and is considered part of a judge's chambers suite. Usually this name is used only in court spaces.	Robing Area/Room	Space for judges to change into their robes.	
ROOF 1	A roof designated by the numbers 1 through 6.	Roof	A construct oriented more than 15° from vertical that Encloses the interior of a Building underneath from the exterior above, affording protection from the elements appropriate to the occupancy and the local climate.	
ROOF 2				
ROOF 3				
ROOF 4				
ROOF 5				
ROOF 6				
ROOF 7 (ETC.)				
SALLY PORT	A fortified space used by legally armed personnel transferring restrained individuals from a vehicle or elevator into a room, corridor, or courtroom.	Sally Port	A small, controlled space with two doors. Access requires that one door must remain closed to proceed, used for security.	
SECONDARY INSP. CANOPY	Secondary Inspection Canopy. Canopy above secondary inspection area. The Secondary Canopy is for vehicle inspection after passing through the Primary Canopy. Use only at a LPOE.	Secondary Inspection Canopy	An overhead roof or structure that is able to provide shade or shelter over an area used for more thorough vehicular inspection.	
SHOP	Room devoted to building operations and maintenance related to the following fields: carpentry, electrical, mechanical, general maintenance, paint, plumbing, or any combination of these fields.	Shop Area	A place where things are crafted	
SNACK BAR	Food counter, room, or area where food, beverages, and light meals are sold.	Snack Bar	A small restaurant serving light meals or a counter in some other establishment having the same function.	
SNDLK.	Sound Lock. Room that provides an acoustical buffer to eliminate the transfer of sound to adjoining space.	Sound Lock	Room that provides an acoustical buffer to eliminate the transfer of sound to adjoining space.	

NBSAP ROOM NAME	NBSAP Room Name Definition	Omniclass Room Name	Omniclass Room Name Definition	Condition
STAIR	Stair designated by the numbers one through ninety-nine.	Stairway	Space used by a static circulation path providing transportation between floors of a structure.	
STAIR 1				
STAIR 10				
STAIR 100				
STAIR 11				
STAIR 12				
STAIR 13				
STAIR 14				
STAIR 15				
STAIR 16				
STAIR 17				
STAIR 18				
STAIR 19				
STAIR 2				
STAIR 20				
STAIR 21				
STAIR 22				
STAIR 23				
STAIR 24				
STAIR 25				
STAIR 26				
STAIR 27				
STAIR 28				
STAIR 29				
STAIR 3				
STAIR 30				
STAIR 31				

NBSAP ROOM NAME	NBSAP Room Name Definition	Omniclass Room Name	Omniclass Room Name Definition	Condition
STAIR 32				
STAIR 33				
STAIR 34				
STAIR 35				
STAIR 36				
STAIR 37				
STAIR 38				
STAIR 39				
STAIR 4				
STAIR 40				
STAIR 41				
STAIR 42				
STAIR 43				
STAIR 44				
STAIR 45				
STAIR 46				
STAIR 47				
STAIR 48				
STAIR 49				
STAIR 5				
STAIR 50				
STAIR 51				
STAIR 52				
STAIR 53				
STAIR 54				
STAIR 55				
STAIR 56				

NBSAP ROOM NAME	NBSAP Room Name Definition	Omniclass Room Name	Omniclass Room Name Definition	Condition
STAIR 57				
STAIR 58				
STAIR 59				
STAIR 6				
STAIR 60				
STAIR 61				
STAIR 62				
STAIR 63				
STAIR 64				
STAIR 65				
STAIR 66				
STAIR 67				
STAIR 68				
STAIR 69				
STAIR 7				
STAIR 70				
STAIR 71				
STAIR 72				
STAIR 73				
STAIR 74				
STAIR 75				
STAIR 76				
STAIR 77				
STAIR 78				
STAIR 79				
STAIR 8				
STAIR 80				

NBSAP ROOM NAME	NBSAP Room Name Definition	Omniclass Room Name	Omniclass Room Name Definition	Condition
STAIR 81				
STAIR 82				
STAIR 83				
STAIR 84				
STAIR 85				
STAIR 86				
STAIR 87				
STAIR 88				
STAIR 89				
STAIR 9				
STAIR 90				
STAIR 91				
STAIR 92				
STAIR 93				
STAIR 94				
STAIR 95				
STAIR 96				
STAIR 97				
STAIR 98				
STAIR 99				
STAIR A				
STAIR B				
STAIR C				
STAIR D				
STAIR E				
STAIR F				
STAIR G				

NBSAP ROOM NAME	NBSAP Room Name Definition	Omniclass Room Name	Omniclass Room Name Definition	Condition
STAIR H				
STAIR I				
STAIR J				
STAIR K				
STAIR L				
STAIR M				
STAIR N				
STAIR O				
STAIR P				
STAIR Q				
STAIR R				
STAIR S				
STAIR T				
STAIR U				
STAIR V				
STAIR W				
STAIR X				
STAIR Y				
STAIR Z				
STORAGE	Room used primarily for storage. Room can also contain files, supplies, and other typical office items. Predominant use of room must be storage. This name includes cold storage rooms such as walk-in freezers or coolers used for food service or by laboratories. A trash or recyclables room used to store Building Common trash, recyclables or dumpsters are also named storage.	Storage Room	A room that is used to store equipment or materials and that serves multiple room use categories, organizational units, or buildings.	
SUPPLY	Room used to contain/store consumable office supplies and other typical office items. Can also be used to designate a room that contains/stores lab supplies and other consumable items that may be associated with labs, medical or law enforcement.	Supply Room	Room for storage of regularly used supplies, such as in an educational or office facility	

NBSAP ROOM NAME	NBSAP Room Name Definition	Omniclass Room Name	Omniclass Room Name Definition	Condition
SWITCH RM.	Can also be used to designate a room that contains/stores lab supplies and other consumable items that may be associated with labs, medical or law enforcement	Switch Room		Contains electrical switch gear and equipment.
TELE.		Telecommunications Room		A designated room containing telecommunications equipment.
TELLER	Room where a teller conducts business. A teller station within an open office setting, such as in a credit union, is usually not assigned as a separate space. A room within the building line such as a room for a drive-up window teller is assigned the room name TELLER.	Bank Teller Space		Area fit-up for face-to-face customer service usually over a counter
TOILET	Toilets available to either men or women.	Unisex Restroom		Handicapped toilet for individual use by men or women, or for family use.
TRAINING	Room used to conduct training. Note the difference between a classroom and a training room is the training room has no special build-out.	Lecture Classroom		A room in which teaching or learning activities can take place.
TRUCK PRIMARY	Canopy area in which the initial inspection of commercial vehicular traffic (primarily trucks) entering the U.S. takes place. The Truck Primary is also the entry way into further commercial inspection and/or passage through the LPOE for commercial vehicles. It usually includes booths and canopies over booths.	Primary Truck Inspection Canopy		An overhead roof or structure and/or booths that are able to provide shade or shelter over an area utilized by commercial vehicular traffic inspection personnel.
TRUCK SECONDARY	Area for a more thorough examination of the contents of commercial vehicles. The secondary commercial area and docks are used for inspection of commercial vehicles, control of material goods, collection of duties, and confiscation of contraband. Docks are used to load and unload materials for inspection. Areas can include the commercial lot, commercial dock, commercial building, truck scale, empty vehicle inspection, truck radiographic inspection, Non-Invasive Inspection (NII), bulk material inspection, bird quarantine area. Often associated with Customs and Border Patrol (CBP) and Animal and Plant Health Inspection Service (APHIS) facilities.	Secondary Truck Inspection Canopy		An overhead roof or structure and/or docks that are able to provide shade or shelter over an area utilized for more thorough commercial vehicular traffic inspection.
TUNNEL	A tunnel is an underground or underwater passageway, dug through the surrounding soil/earth/rock and enclosed except for entrance and exit, commonly at each end.	Connector		A covered or enclosed bridge, walk-way, tunnel or other similar connecting element between two separate buildings.
TV STUDIO	Television Studio. Rooms where television broadcasts are produced. This includes associated rooms.	Media Production		Space fit-up with features facilitating the production of televised programming live or recorded.
Undefined				
VAULT	Room for the safekeeping of valuables that typically is above standard build-out.	Vault		A reinforced room or compartment in a bank building where valuables are stored
VEHICLE RAMP	For vehicular roadway traffic only. A fully enclosed vehicular ramp (leading to or inside Structured Parking) that fits the requirements of a vertical penetration is	Interior Parking Ramp and Circulation		Interior space including ramps used to circulate vehicles and providing access to parking stalls.

NBSAP ROOM NAME	NBSAP Room Name Definition	Omniclass Room Name	Omniclass Room Name Definition	Condition
	named Vehicle Ramp.			
VENDING	Room or area set aside for machines dispensing food or beverages.	Vending Machine Area	Space accommodating vending equipment for non-perishable goods	
VERT. PEN.	Vertical Penetration. Vertical penetrations and their enclosing walls are design elements that penetrate the slab between floors and must be 9 square feet or greater.	Vertical Penetration	opening in a floor that serves a building or system distribution function	
VEST.	Vestibule. A small passage, hall, or room between a door or room and another room, corridor, or lobby.	Vestibule	A small passage, hall, or room between a door or room and another room, corridor, or lobby	
WAITING	Area for patron/clientele traffic. Can include seating. Also can include drivers' waiting rooms at a LPOE.	Waiting Room	A room in some public space for people to wait.	
WAREHOUSE	Space used to store, accumulate, or collect house goods or wares. Spaces with industrial lighting, unfinished flooring, above-standard floor loading, ceiling open to structure, large column spacing, overhead doors, and/or minimal (or no) HVAC.	Warehouse Spaces	Space specifically designed for the storage of raw material, in process materials or finished goods.	
WEIGHT RM.	Room used for physical wellness that includes improvements to accommodate weight-lifting equipment.	Weight Room	Space used for weightlifting, either using exercise equipment or free weights.	
WET AREA	Use WET AREA for a shower room, a dishwashing room, and a sink area in a conference room. Do not use WET AREA for a break area or room, exam room, toilet, laboratory, custodial closet, holding cell, kitchen, or water fountain.	Dishwashing Station	Area and equipment for the cleaning of cooking and serving utensils	Where Space Class = CFT, FDS All others change to Undefined
		Shower Space	A space in which one bathes underneath a spray of water.	Where Space Class = FIT, PTL All others change to Undefined
WOMEN	Toilets used exclusively by women.	Womens Restroom	Toilet(s) used exclusively by women.	
WORK RM.	Work Room. An open room or area used by many people performing various work-related tasks. Different from OPEN OFFICE because there are no office-related workstations.	Office Service	A space that directly serves an office or group of offices as an extension of the activities in those spaces.	
Z PORTAL MONITOR	A high-throughput screening gateway used to inspect trucks and cargo for threats.	High-throughput Cargo Inspection	High-throughput cargo screening area used for non-invasive vehicular and cargo inspection.	

Addendums

This section identifies the Addendums that are companions to this NBSAP policy. At this time there is only one Addendum. When any Addendums are published, they will be listed here so that the reader is aware of them and uses them as appropriate. They are not attached to this document so that both the Addendums and the NBSAP can be updated independently. GSA associates and external readers can use general SDM link in the reference section to see any Addendums as well as any Clarifications to this policy.

1. **Land Port of Entry (LPOE) Space Assignment Policy Addendum**

This document covers specific situations and spaces found only on LPOEs.



References

PBS Spatial Data Management

<http://www.gsa.gov/sdm>

Building Information Modeling (BIM) Guides

<http://www.gsa.gov/bim>

- (1) BIM Guide 02, Spatial Program Validation

Building Owners and Managers Association (BOMA)

<http://www.boma.org/>

- (1) Office Buildings: ANSI/BOMA Z65.1-2017, Standard Methods of Measurement
- (2) Gross Areas of a Building: ANSI/BOMA Z65.3-2018, Standard Methods of Measurement

Pricing Desk Guide

<http://www.gsa.gov/rentpricingpolicy>

CAD Standards

<http://www.gsa.gov/cad>

PBS Facilities Standard (P-100)

<http://www.gsa.gov/p100>

[GSA Courthouse Program](#)

Land Ports of Entry

<http://www.gsa.gov/lpoe>

Note: If a GSA URL changes or the link becomes unusable, use a text string search on <https://www.gsa.gov/> or another capable search engine.

Contacts

Central Office Leadership: Office of Portfolio Management and Customer Engagement

- Chad Gilchrist, Acting Assistant Commissioner
- Christopher Giavis, Director, Pricing Policy and Tools Division

Central Office SDM National Program Manager

Name	Email	Phone
Valerie Butler	valerie.butleri@gsa.gov	202-684-5579

National Business Space Assignment Policy Revision Team

Name	Email	Phone
Ravi Vaghani	ravi.vaghani@gsa.gov	312-350-1751
Todd Lao	todd.lao@gsa.gov	212-264-0299
Robert Henderson	robert.henderson@gsa.gov	817-978-1015



GSA Public Buildings Service

Office of Portfolio Management and Customer Engagement

1800 F Street, NW

Washington, DC 20405

www.gsa.gov
