

**Facilities Standards  
for the  
Public Buildings Service (PBS-PQ100.1)**

**Arrangement of Chapters**

Chapter 1: *General Requirements*

Appendix 1.A: *Life Cycle Cost Example*

Chapter 2: *Site Planning and Landscape Design*

Chapter 3: *Architectural and Interior Design*

Chapter 4: *Structural Engineering (Includes Seismic Design)*

Chapter 5: *Mechanical Engineering*

Chapter 6: *Electrical Engineering*

Appendix 6.A: *Energy Efficient Design of New Buildings*

Chapter 7: *Fire Protection Engineering*

Chapter 8: *Security Design*

Index

**CHAPTER 1  
GENERAL REQUIREMENTS**

Purpose of the Facilities Standards for the Public  
Buildings Service ..... 1  
Arrangement of Chapters..... 3

Applicability of the Facilities Standards ..... 4  
GSA Building Types ..... 4  
Office Buildings..... 4  
Courts..... 4  
Border Stations..... 4  
Child Care Centers ..... 4  
Other Building Types..... 5  
Types of Facilities ..... 5  
New Construction of GSA Owned Facilities ..... 5  
Repair and Alteration Projects ..... 5  
Historic Buildings ..... 5

General Design Philosophy..... 6  
Design Quality ..... 6  
Life Expectancy ..... 6  
Frequent Changes ..... 6  
Cost Effectiveness..... 6  
Building Maintenance..... 7  
Art in Architecture ..... 7

Codes and Standards ..... 9  
Building Codes ..... 9  
Editions of National Codes ..... 9  
Conflicts between Codes and GSA Requirements ..... 9  
Deviations from Building Code Provisions ..... 9  
Local Building Codes..... 10  
Code Requirements for Alterations..... 10  
Zoning Ordinances..... 10

*CHAPTER 1. GENERAL REQUIREMENTS*

---

Mandatory Design Standards .....	11
Accessibility Standards .....	11
Conflicts with Historic Preservation .....	11
Energy Conservation Standards .....	11
Compliance with National Environmental Policy Act.....	12
Environmental Policies .....	14
Building Materials .....	14
Prohibited Materials.....	14
Lead-Based Paint in Alteration Projects.....	14
Recycled Materials.....	14
Abatement of Asbestos in Existing Buildings .....	15
Design .....	16
Construction.....	16
Inspections .....	16
Laboratories .....	16
Radon Mitigation.....	17
New Construction .....	17
Alterations.....	17
Design Considerations .....	17
Submission Requirements.....	18
Specifications Requirements .....	18
Technical Requirements for Specifications.....	18
Life Cycle Costing .....	20
Cost Elements.....	20
Notation .....	20
Sunk Costs .....	21
First Costs .....	21
Non-recurring Future Costs .....	21
Combined Procedure.....	22
Uniform Annually Recurring Constant Dollar Costs .....	22
Annually Recurring Costs.....	22
Recurring Fuel Costs.....	23

Procedures and Approach.....	24
Defining Alternates .....	24
Comparison of Design Alternates .....	24
Analysis Period .....	24
First Costs .....	25
Future Cost Projections.....	25
Changing Cost Relationships .....	26
Residual Service Worth .....	27
Analysis Presentation.....	27
Computer Programs .....	27
Sensitivity Analysis.....	28
Interpretations .....	28
Systems Selection .....	28

**APPENDIX 1.A**  
**Life Cycle Cost Example**

Life Cycle Cost Example .....	1.A-1
Life Cycle Cost Summary .....	1.A-1
References .....	1.A-1
The Sample Building .....	1.A-2
Mechanical and Architectural Systems Alternates .....	1.A-3
Alternate #1: (Base System).....	1.A-3
Alternate #2.....	1.A-4
Alternate #3.....	1.A-4
Alternate #4.....	1.A-4
Energy Analysis.....	1.A-5
Temperature/Humidity Data .....	1.A-5
Other Input Parameters .....	1.A-5
Life Cycle Cost Study Input Parameters.....	1.A-7
LCC General Assumptions .....	1.A-8
Life Cycle Cost Results .....	1.A-9
Recommendation.....	1.A-10
Energy Analysis Summary .....	1.A-10
Sample Worksheets .....	1.A-11
Life Cycle Cost Analysis Worksheets	

**CHAPTER 2  
SITE PLANNING AND LANDSCAPE DESIGN**

General Approach ..... 1

Codes and Standards ..... 3

    Zoning Regulations ..... 3

        Parking ..... 3

    Standards for Site Planning and Landscape Design ..... 4

        Local Standards ..... 4

        Historic Preservation ..... 4

Site Analysis 5

    Survey ..... 5

    Geotechnical Investigation ..... 5

    Archeological Testing ..... 5

General Site Planning Criteria ..... 6

    Existing Site Features and Existing Vegetation ..... 6

    Mitigating Undesirable Conditions ..... 6

    Energy Conservation ..... 6

    Future Expansion ..... 6

Grading 7

    Slopes ..... 7

    Grading Adjacent to Buildings ..... 9

    Grading Around Existing Trees ..... 9

    Cut and Fill ..... 9

    Grading and Flood Plains ..... 9

    Erosion and Sediment Control ..... 10

        Storm Water Detention ..... 10

Site Utilities 11

    Utilities Services ..... 11

        Location of Above-ground Utility Elements ..... 11

    Water Distribution ..... 11

        Local Water Authority ..... 11

        Dual Service ..... 11

        Locating Water Lines ..... 11

***FACILITIES STANDARDS FOR THE PUBLIC BUILDINGS SERVICE***

---

Sizes of Pipes .....	11
Post Indicator Valves .....	12
Fire Hydrants .....	12
Detector Check Valves.....	12
Sanitary Sewer System .....	12
Local Sewer Authority .....	12
Discharge in Remote Rural Areas .....	12
Locating Sewer Pipes.....	12
Sizes of Pipes .....	12
Manholes.....	13
Service Line Connections .....	13
Cleanouts .....	13
Storm Drainage System .....	13
Gravity Drainage.....	14
Location of Storm Drainage Pipes .....	14
Site Circulation Design .....	15
Urban Site with Underground Parking .....	15
Service Traffic .....	15
Drop-Off .....	15
Vehicular Drives, Parking Lots and Service Areas .....	15
Entrance Drives.....	15
Surface Parking Lots.....	16
Walkways .....	16
Walkway Width .....	16
Pavements and Curbs .....	17
Materials .....	17
Texture and Pattern .....	17
Curbs.....	17
Drives.....	17
Fire Lanes .....	17
Service Areas .....	17
Pavement Markings .....	17
Signage for Roads and Parking Lots.....	17
Landscape Design .....	18
Maintenance Considerations.....	18
General Design Principles .....	18

**CHAPTER 1. GENERAL REQUIREMENTS**

---

Landscape Elements .....	19
Courts and Plazas .....	19
Roof Gardens .....	19
Fountains, Reflecting Pools and Ponds.....	20
Planters.....	20
Sculpture .....	20
Rocks and Boulders .....	20
Plant Materials .....	21
Existing Vegetation.....	21
Energy Conservation Considerations .....	21
Species Selection .....	21
Hardiness and Availability .....	21
Demanding Plants .....	21
Growth Habits .....	21
Placement .....	22
Planting Practices .....	22
Tagging .....	22
Staking .....	22
Warranties .....	23
Mulch.....	23
Irrigation for Landscaping.....	24
System Design.....	24
General Criteria.....	24
Metering.....	24
Zoning.....	24
Application Rates.....	25
Fittings .....	25
Controls.....	25
Maintenance Considerations .....	25
Landscape Lighting.....	26
Color .....	26
Fixtures .....	26
Controls.....	26

***FACILITIES STANDARDS FOR THE PUBLIC BUILDINGS SERVICE***

---

Site Furniture .....	27
Seating .....	27
Trash Containers .....	27
Materials .....	27
Site Signage 28	
Construction Signs.....	28
All Construction Signs .....	28
New Construction Signs.....	29
Repair and Alteration Projects .....	29



**CHAPTER 3  
ARCHITECTURAL AND INTERIOR DESIGN**

General Approach ..... 1

Codes and Standards ..... 4

    Zoning Regulations ..... 4

        Parking ..... 4

    Building Codes ..... 4

        Egress Requirements ..... 4

        Energy Conservation Requirements ..... 5

        Toilet Fixture Requirements ..... 5

    Architectural Design Standards ..... 5

Site and Context ..... 6

    Building Form, Proportion, Scale and Context ..... 6

        Wall Buildings ..... 6

        Object Buildings ..... 7

        Highrise Buildings ..... 7

        Urban or Rural Context ..... 8

        Environmental Sensitivity ..... 8

        Orientation ..... 8

        Exterior Circulation ..... 8

        Building Character and Exterior Materials ..... 8

        Façade Articulation ..... 9

Building Planning ..... 11

    Basic Configurations and Core Placement ..... 11

    Core Placement and Circulation Patterns ..... 11

    Placement of Core Elements and Distances ..... 12

        Elevators ..... 12

        Stair ..... 12

        Toilets ..... 12

        Electrical Closets ..... 12

        Communications Closets ..... 12

    Occupiable Area and Net Usable Space ..... 13

    Building Efficiency ..... 14

***FACILITIES STANDARDS FOR THE PUBLIC BUILDINGS SERVICE***

---

Selecting Conveying Systems .....	15
Elevator Classifications.....	15
Elevator Design.....	16
Escalators .....	18
Wheelchair Lifts.....	19
Planning Module .....	19
Structural Bays.....	19
Column Placement within Planning Module .....	22
Perimeter Columns and Plan Layout at Exterior Wall.....	23
Floor to Floor Heights and Vertical Building Zoning.....	24
Building Fire Protection .....	29
Seismic Design .....	30
Layout .....	30
Buildings in Zones of High Seismicity .....	30
Security Design .....	30
General Layout.....	30
Planning for Future Security Provisions .....	31
Site Design.....	31
Building Entrances.....	31
Building Lobby .....	31
Shops.....	31
Elevators .....	31
Mechanical and Electrical Spaces .....	32
Space Planning.....	33
Office Space .....	33
Floor and Ceiling Grids.....	33
Closed Offices Versus Open Plan .....	34
Utility Placement.....	35
Ceiling Height.....	36
Doors.....	37
Automated Data Processing (ADP) Areas .....	37
Training and Major Conference Rooms.....	37
Internal Corridors.....	37

Planning Tenant Layouts .....	37
Public Spaces.....	38
Entrances and Vestibules .....	38
Entrance Lobbies and Atria.....	39
Elevator and Escalator Lobbies.....	40
Stairways.....	40
Monumental Stairs .....	40
Communicating Stairs .....	40
Emergency Egress Stairs .....	41
Public Corridors .....	41
Pedestrian Tunnels and Bridges .....	43
Building Support Spaces .....	43
Toilet Spaces .....	43
Modular Toilet Room Option.....	44
Staff Locker Rooms .....	48
Custodial Spaces .....	48
Storage Rooms .....	48
Janitor's Closets .....	48
Mechanical and Electrical Rooms.....	49
Equipment Spaces .....	49
Spaces for Uninterruptible Power Systems (UPS) and Batteries.....	49
Electrical Closets .....	50
Communications Closets .....	50
Vertical Shafts .....	50
Loading Docks .....	50
Loading Berths.....	51
Staging Area .....	53
Trash Rooms .....	53
Building Engineer's Space .....	53
Security Control Center .....	53
Fire Control Center .....	53
Specialty Areas.....	54
Food Service Areas .....	54
Child Care Centers .....	54
Laboratories .....	54
Outleased Space .....	54

***FACILITIES STANDARDS FOR THE PUBLIC BUILDINGS SERVICE***

---

Structured Parking .....	55
Parking Layout.....	55
Drive Aisles .....	57
Vehicle Stalls .....	57
Ramps .....	57
Stairs and Elevator Lobbies .....	58
Walkways.....	58
Special Design Considerations.....	59
Acoustics .....	59
Parameters used in Acoustic Design.....	59
Ambient Noise Level .....	59
Noise Isolation .....	59
Noise Isolation Class.....	59
Reverberation Control.....	59
Design Criteria for Building Spaces.....	60
Class A Spaces .....	60
Class B1 Spaces.....	60
Class B2 Spaces.....	60
Class C1 Spaces.....	60
Class C2 Spaces.....	61
Class D Spaces .....	61
Class E Spaces.....	61
Class F Spaces.....	61
Class X Spaces .....	61
Sound Isolation from Exterior Noise Sources.....	62
Fallout Protection .....	62
Building Elements.....	64
Substructure.....	64
Ground Water Control .....	64
Waterproofing .....	64
Underslab Insulation .....	64
Exterior Closure.....	64
Exterior Wall Construction .....	65
Cornerstone .....	65
Commemorative Plaques .....	65

Sun Control Devices .....	65
Exterior Soffits .....	66
Exterior Windows .....	66
Glazing .....	67
Condensation Resistance .....	67
Exterior Doors.....	67
Hardware for Exterior Doors.....	67
Roofing .....	68
Roof Drainage .....	68
Access to Roof.....	68
Roof-mounted Equipment .....	68
Skylights and Sloped Glazing .....	68
Interior Construction.....	69
Partitions .....	69
Interior Finishes .....	69
Doors.....	69
Ceiling Suspension Systems .....	69
Access Flooring .....	70
Building Specialties.....	70
Window Washing Equipment .....	70
Waste Removal Equipment.....	70
Toilet Compartments.....	71
Toilet Accessories .....	71
Flagpoles.....	71
Telephone Enclosures .....	71
Drinking Fountains .....	71
Window Blinds .....	71
Elevators .....	71
Interior Landscape .....	73
Artwork and Graphics .....	74
Artwork.....	74
Graphics and Signage .....	74
Interior Finishes .....	75
Minimum Standards for Finishes in Tenant Spaces.....	75
Carpets.....	75
Vinyl Wall Covering .....	76
Colors and Textures .....	76

***FACILITIES STANDARDS FOR THE PUBLIC BUILDINGS SERVICE***

---

General Office Space (Open and Enclosed Offices).....	76
Floors	76
Carpet for Raised Access Floor.....	77
Walls	77
Ceilings .....	77
Standard Ceiling Tile.....	77
Doors	77
Automated Data Processing Areas .....	77
Training and Conference Rooms.....	77
Internal Corridors .....	78
Public Spaces	78
Entrances and Vestibules .....	78
Floors- .....	78
Walls.....	78
Doors .....	78
Entrance Lobbies and Atria.....	79
Flooring .....	79
Walls.....	79
Ceiling Systems.....	79
Elevator and Escalator Lobbies.....	80
Floors.....	80
Walls.....	80
Ceilings.....	80
Elevators .....	80
Floors.....	80
Walls.....	80
Ceilings.....	81
Doors .....	81
Freight Elevators .....	81
Stairways (closed).....	81
General Requirements .....	81
Floors.....	81
Walls.....	81
Ceilings.....	81
Doors .....	82
Stairways (open) .....	82
Floors.....	82
Public Corridors .....	82

Floors.....	82
Walls.....	82
Ceilings.....	82
Doors .....	83
Pedestrian Tunnels and Bridges .....	83
Floors.....	83
Walls.....	83
Ceilings.....	83
Windows.....	83
Building Support Spaces .....	84
General Use Toilets.....	84
Equipment Spaces and Maintenance Shops.....	84
Staff Locker Rooms and Custodial Spaces .....	84
Building Engineer's Office and Security Control Center .....	84
Specialty Areas.....	85
Food Service Areas.....	85
Cafeteria Kitchens and Serveries.....	85
Kitchens Other Than Cafeteria Kitchens .....	85
Dining Areas .....	85
Child Care Centers .....	85
Space Planning for Open Office Space.....	86
Space Layouts .....	86
Views .....	86
Acoustics.....	87
Systems Furniture .....	87
Alterations in Existing Buildings and Historic Structures.....	88
Evaluation of Existing Systems .....	89
Code Requirements for Alterations .....	89
Placing Mechanical and Electrical Systems in Renovated and Rehabilitated Buildings.....	90
Vertical Distribution.....	90
Horizontal Distribution .....	90
Placement of Main Mechanical and Electrical Equipment .....	91
Elevators .....	91
Space Planning Strategies.....	91

***FACILITIES STANDARDS FOR THE PUBLIC BUILDINGS SERVICE***

---

Office Space.....	91
Food Service .....	91
Acoustics 92	
Office Space.....	92
Historic Buildings .....	92
Alteration of Building Elements.....	92
Exterior Closure .....	92
Re-roofing .....	92
Uncommon Products Used in Rehabilitations .....	93



**CHAPTER 4**  
**STRUCTURAL ENGINEERING**  
**(Includes Seismic Design)**

General Approach .....	1
Codes and Standards .....	3
Standards for Structural Design.....	3
Live Loads .....	5
Building Configuration in Earthquake Zones .....	6
Structural Symmetry .....	6
Vertical Structural Uniformity .....	6
Story-to-Story Differentials .....	6
Structural Systems .....	7
Steel Framing Systems .....	7
Unshored Composite Beams .....	7
Shored Composite Beams.....	7
Cambered Composite Beams and Girders .....	7
LRFD versus ASD .....	7
Concrete Framing Systems.....	8
Cast-in-Place Systems.....	8
Precast Systems.....	8
Pre-tensioning and Post-tensioning.....	8
Stability and Serviceability Criteria .....	9
Progressive Collapse .....	9
Drift .....	9
Vibration of Floor Systems.....	9
Corrosion Protection.....	9
Steel .....	9
Concrete .....	10
Concrete Elements in Parking Structures.....	10
Construction Tolerances .....	10
Concrete Slab Finish Tolerances.....	10

***FACILITIES STANDARDS FOR THE PUBLIC BUILDINGS SERVICE***

---

Instrumentation for Buildings in Earthquake Zones 3 and 4.....	11
Base Isolation.....	11
Foundation Considerations .....	12
Geotechnical Considerations .....	12
Protection of Adjoining Property .....	12
Sheeting, Shoring and Underpinning .....	12
Footings Outside Property Lines.....	12
Attachment of Nonstructural Elements .....	13
Exterior Cladding .....	13
Partitions .....	13
Ceiling Systems.....	14
Suspended Grid Systems.....	14
Monolithic Ceilings.....	14
Raised Flooring (Access Flooring).....	14
Furnishings and Equipment.....	15
Fixed Casework and Equipment .....	15
Mechanical and Electrical Equipment .....	15
Equipment Anchorage .....	15
Equipment Placed on Vibration Isolation Devices.....	16
Compressed Gas Cylinders .....	16
Batteries .....	16
Piping, Conduit and Ductwork .....	16
Piping (Including Electrical Conduit) and Ductwork.....	16
Piping for Fire Protection.....	16
Alterations in Existing Buildings and Historic Structures.....	17
General Design Considerations for Structural Upgrading .....	17
Gravity Loads and Wind Loads .....	17
Seismic Performance .....	17
Upgrade Priorities .....	18
Seismic Upgrades for Historic Buildings.....	18
Seismic Strengthening Criteria for Nonstructural Elements.....	18

**CHAPTER 5  
MECHANICAL ENGINEERING**

General Approach ..... 1

Codes and Standards ..... 4

    Mechanical Design Standards ..... 4

Placing Mechanical Systems in Buildings ..... 5

    Planning Grid, Floor Grid and Ceiling Grid ..... 5

    Horizontal Distribution of HVAC Elements ..... 7

    Vertical Zoning of Floor-to-Floor Space ..... 7

    Vertical Distribution..... 8

    Historic Structures..... 9

General Design Criteria..... 10

    Energy Conservation..... 10

    Water Conservation ..... 10

    Visual Impact ..... 10

    Life Cycle Costing ..... 10

    Energy Analysis ..... 11

    Heat Balance Analysis ..... 11

    Selecting Fuel Sources..... 11

    Sizing Standards for Equipment and Systems ..... 12

    Operation and Maintenance Considerations ..... 13

HVAC Design Criteria ..... 14

    Outdoor Design Criteria..... 14

    Indoor Design Temperatures and Relative Humidity..... 14

    Outside Air and Ventilation Criteria ..... 15

    Indoor Air Quality..... 16

Internal Heat Gain ..... 16

    Occupancy Levels..... 16

    Lighting Levels ..... 17

Acoustical Requirements ..... 17

Zoning Criteria for HVAC Systems ..... 17

Special HVAC and Plumbing Requirements for Building Spaces ..... 18

    Entrance Vestibules..... 18

***FACILITIES STANDARDS FOR THE PUBLIC BUILDINGS SERVICE***

---

Mechanical Rooms.....	18
Kitchens and Dishwashing Areas.....	18
Toilet Rooms.....	19
Electrical Equipment Rooms.....	19
Communications Closets.....	19
Elevator Machine Rooms.....	19
Emergency Generator Rooms .....	19
UPS Battery Rooms .....	19
Loading Docks .....	19
Heating Systems .....	20
Steam Heating .....	20
Hot Water Systems .....	20
Water Treatment .....	20
Temperature and Pressure Drop.....	20
Piping .....	21
Freeze Protection .....	21
Electric Resistance Heat.....	21
Radiant Heat.....	21
Boilers and Heat Exchangers.....	22
Boilers.....	22
Heat Exchangers .....	22
Fuel Oil Piping.....	22
Underground Fuel Oil Tanks .....	22
Other Tanks and Piping .....	22
Cooling Systems .....	23
Chilled Water Systems .....	23
Chillers.....	23
Environmental Protection .....	23
Light Load or Overtime Requirements .....	24
Chiller Controls.....	24
Chilled Water Pumps .....	24
Piping .....	24
Freeze Protection .....	25
Condenser Water.....	25
Water Treatment .....	25
Cooling Towers.....	25
Air-Cooled Condensers.....	26

**CHAPTER 1. GENERAL REQUIREMENTS**

---

Special Cooling Applications .....	27
Water-side Economizer Cycle.....	27
Computer Room Air-Conditioning Units.....	27
Combined Heating and Cooling Systems.....	28
Heat Pump Systems.....	28
Unitary Systems (Factory package systems).....	28
Ventilation and Air Distribution.....	29
Pressurization.....	29
Special Ventilation Requirements .....	29
Toilets .....	29
Food Service Areas.....	29
Air Distribution Systems.....	30
Constant Volume Systems.....	30
Single Zone Systems.....	30
Multi-zone and Dual Duct Systems .....	30
Multi-zone Systems .....	30
Dual Duct Systems.....	30
Variable Air Volume (VAV) Systems.....	32
Perimeter Zones .....	32
Volume Control .....	32
Terminals .....	34
Noise Control in VAV Systems .....	34
Air Handling Units .....	35
Unit Types.....	35
Vertical and Horizontal Arrangement.....	36
Air Delivery Capacity .....	36
Return Air or Exhaust Fan .....	37
Mixing Boxes.....	38
Filtration.....	38
Cooling Coils .....	38
Heating Coils .....	38
Humidification .....	38
Supply Air Fans .....	39
Noise Control in Air Handling Unit.....	39
Air-side Economizer Cycle.....	39
Computer Room Air Handling.....	40

***FACILITIES STANDARDS FOR THE PUBLIC BUILDINGS SERVICE***

---

Ductwork .....	40
Supply and Return Ductwork .....	41
Ductwork Pressure .....	41
Sizing of Ductwork .....	41
Ductwork Construction .....	42
Insulation .....	42
Ceiling Plenum Supply .....	42
Plenum and Ducted Returns.....	42
Noise Control .....	43
Duct Liners.....	43
Exhaust Duct Systems .....	44
Special Systems .....	45
Heat Recovery .....	45
Heat Reclaim Chillers .....	45
Exhaust Air Heat Recovery.....	45
Heat Exchangers .....	45
Thermal Storage .....	45
Solar Heating and Cooling .....	46
Plumbing Systems .....	47
Stormwater Drainage System .....	47
Sanitary Sewer System .....	47
Automatic Sewage Ejectors .....	47
Acid Wastes .....	47
Domestic Water .....	47
Exterior Wall and Yard Hydrants .....	48
Domestic Hot Water .....	48
Hot Water Heating .....	48
Point of Use Hot Water Heater .....	48
Recirculation .....	48
Plumbing Fixtures .....	49
Toilets .....	49
Lavatories.....	49
Drinking Fountains .....	49
Natural Gas Systems.....	49
Service Entrance .....	49
Gas Piping within Building Spaces.....	49

Pumping Systems .....	50
Hydronic, Closed Loop Systems .....	50
Variable Flow Pumping .....	50
Primary/Secondary Pumping .....	51
Piping Systems .....	52
Cathodic Protection.....	52
Piping Material.....	52
Isolation of Piping at Equipment.....	53
Provisions for Piping in Earthquake Zones.....	53
Piping System Identification .....	53
Vibration Isolation, Acoustical Isolation and Seismic Design for Mechanical Systems .....	54
Noise and Vibration Isolation.....	54
Mechanical Room Isolation .....	54
Mechanical Chases.....	54
Isolator Types.....	54
Concrete Inertia Bases .....	54
Ductwork .....	54
Piping Hangers and Isolation .....	54
Layout of Mechanical Spaces .....	56
Vertical Clearances .....	56
Horizontal Clearances .....	56
Lighting.....	56
Housekeeping Pads .....	56
Piping .....	56
Ductwork .....	56
Operation and Maintenance Manuals .....	56
Posted Instructions .....	57
Operating Instructions.....	57
Control Systems .....	58
Automatic Temperature and Humidity Controls .....	58
Controls.....	58
Temperature Controls .....	58
Temperature Reset Controls .....	58
Air Systems.....	58

***FACILITIES STANDARDS FOR THE PUBLIC BUILDINGS SERVICE***

---

Hydronic Systems .....	59
Testing and Balancing Equipment and Systems.....	59
Testing Stations.....	59
Thermometers and Gauges.....	60
Building Automation System (BAS).....	61
Level of Integration.....	61
Software .....	61
Energy Conservation.....	62
Maintenance Scheduling.....	62
System Design Considerations.....	62
Energy Measurement Instrumentation .....	63
Alterations in Existing Buildings and Historic Structures.....	64
Evaluation of Existing Systems .....	66
Code Requirements for Alterations .....	66
Placing Mechanical Systems in Renovated Buildings.....	67
Vertical Distribution.....	67
Horizontal Distribution .....	67
General Design Considerations for Alterations .....	67
Re-use of Existing Equipment .....	67
Removal of Materials Not Re-used.....	68
Hazardous Material .....	68
Phasing.....	68
Cost Considerations .....	68



**CHAPTER 6  
ELECTRICAL ENGINEERING**

General Approach ..... 1

Codes and Standards ..... 3

    Electrical Design Standards ..... 3

Placing Electrical Systems in Buildings ..... 4

    Electrical Closets ..... 4

    Communication Closets ..... 4

    Planning Grid, Floor Grid and Ceiling Grid ..... 4

    Horizontal Distribution of Power and Communications ..... 6

    Vertical Zoning of Floor-to-Floor Space ..... 10

    Vertical Distribution ..... 11

General Design Criteria ..... 12

    Energy Conservation ..... 12

    Visual Impact ..... 12

    Equipment Grounding Conductor ..... 12

    Lightning Protection ..... 12

    Cathodic Protection ..... 12

    Operations and Maintenance Considerations ..... 13

Electrical Load Analysis ..... 14

    Standards for Sizing Equipment and Systems ..... 15

Utility Coordination and Site Considerations ..... 16

    Power Company Coordination ..... 16

    Site Considerations ..... 16

    Communications Service Coordination ..... 16

Site Distribution ..... 17

    Direct Buried Conduit ..... 17

    Concrete-Encased Ductbank ..... 17

    Duct Sizes ..... 17

    Manholes ..... 18

        Stubs ..... 18

***FACILITIES STANDARDS FOR THE PUBLIC BUILDINGS SERVICE***

---

Primary Distribution.....	19
Medium Voltage Switchgear .....	19
Conductors .....	19
Spot Network Transformers.....	19
Double-ended Substations .....	19
Transformers .....	20
Secondary Distribution .....	21
Main Switchboards .....	21
Grounding .....	21
Ground Sources.....	21
Submetering .....	22
Power Factor Correction .....	22
Motor Control Centers .....	22
Elevator Power.....	22
Secondary Distribution Systems.....	22
Bus Duct .....	24
Conductors .....	24
Power Distribution Panels.....	24
Lighting and Receptacle Panelboards .....	24
Panelboards Serving Electronic Equipment.....	24
Wiring Devices .....	25
Placement of Receptacles .....	25
Corridors .....	25
Office Space.....	25
Raised Access Floor.....	25
Cellular Floor Duct .....	26
Floor Duct Encased in Concrete .....	26
Number of Receptacles .....	26
Conference Rooms.....	26
Maintenance Shops .....	26
Electrical and Communications Closets.....	26
Main Mechanical and Electrical Rooms .....	26
Toilet Rooms.....	26
Emergency Power Systems .....	27
Batteries .....	27

Generator Systems.....	27
Service Conditions.....	27
Capacity.....	28
Emergency Power Loads.....	28
Distribution System.....	29
Generator Derangement Alarms.....	29
Automatic Transfer Switches.....	29
Load Bank.....	29
Paralleling.....	29
Fuel Distribution System.....	29
Uninterruptible Power Systems.....	30
Solid State versus Rotary UPS.....	30
Electrical Service and Bypass Circuits.....	31
Electrical Service Size.....	31
Critical Technical Loads.....	31
Emergency Electrical Power Source Requirements.....	31
System Status and Control Panel.....	31
UPS Environmental Status Panel.....	31
UPS and Battery Room Requirements.....	32
Battery Racks.....	32
Battery Cabling.....	32
Acoustical Treatment.....	32
Paralleling.....	32
Redundancy.....	32
Computer Center Power Distribution.....	33
Power Distribution Units (PDU's).....	33
Non-linear Loads.....	33
Computer Center Grounding.....	33
Low Frequency Power System Grounding.....	33
High Frequency Power System Grounding.....	34
Common Mode Noise Reduction.....	34
Emergency Power Off (EPO) Systems.....	35
Lighting.....	36
Interior Lighting.....	36

***FACILITIES STANDARDS FOR THE PUBLIC BUILDINGS SERVICE***

---

Illumination Levels .....	36
Energy Efficient Design .....	36
Light Sources .....	38
General Lighting Fixture Criteria .....	38
Lighting Fixture Features .....	38
Baseline Building Fixture .....	38
Fixture Ballasts .....	38
Lighting Criteria for Building Spaces .....	39
Office Lighting .....	39
ADP Areas .....	39
Conference Rooms and Training Rooms .....	39
Lobbies, Atria, Tunnels and Public Corridors .....	39
Mechanical and Electrical Spaces .....	39
Dining Areas and Serveries .....	39
Character-Defining Spaces in Historic Structures .....	39
Structured Parking .....	40
High Bay Lighting .....	40
Supplemental Emergency Lighting .....	40
Lighting Controls .....	40
Lighting Configuration Benefits .....	40
Enclosed Space Lighting Controls .....	41
Open Space Lighting Controls .....	41
Occupancy Sensor Lighting Controls .....	42
Ambient Light Sensor Controls .....	42
Exterior Lighting .....	42
Parking and Roadway Lighting .....	42
Entrances .....	42
Loading Docks .....	42
Controls .....	42
Raceway System for Communications .....	43
Communications Frame Room .....	43
Communication Closets .....	43
Communications Raceways .....	44
Raised Access Floor .....	44
Above Ceiling Delivery .....	44
Communications Outlets .....	44

**CHAPTER 1. GENERAL REQUIREMENTS**

---

Layout of Main Electrical Rooms .....	45
Vertical Clearances .....	45
Horizontal Clearances .....	45
Lighting.....	45
Housekeeping Pads.....	45
Operation and Maintenance Manuals .....	45
Posted Instructions .....	46
Alterations in Existing Buildings and Historic Structures.....	47
Evaluation of Existing Systems .....	48
Code Requirements for Alterations .....	49
Placing Electrical and Communications Systems in Renovated Buildings .....	49
Vertical Distribution.....	49
Horizontal Distribution .....	50
General Design Considerations for Alterations .....	50
Re-use of Existing Equipment .....	50
Removal of Materials Not Re-used.....	50
Hazardous Materials .....	51
Phasing.....	51
Cost Considerations .....	51
Building Service .....	51
Secondary Power Distribution.....	51
Computer Center Power .....	51
Lighting .....	52
General Renovations .....	52
Historic Structures.....	52
Communications Distribution.....	53
Telephone.....	53
Data.....	53

**APPENDIX 6.A**  
**Energy Efficient Design of New Buildings**

Energy Efficient Design of New Buildings.....	6.A-1
---	-------

**CHAPTER 7  
FIRE PROTECTION ENGINEERING**

General Approach ..... 1

Codes and Standards ..... 2

    Building Codes ..... 2

    Local Building Codes and Zoning Ordinances ..... 2

    Fire Protection Design Standards ..... 3

Site Considerations ..... 4

    Emergency Vehicle Access ..... 4

    Water Supply ..... 4

    Secondary Water Supply ..... 4

    Remote Rural Buildings ..... 4

    Potable Water ..... 4

Architectural Requirements ..... 5

    Building Occupancy and Floor Area Requirements ..... 5

        Building Occupancies ..... 5

        High Severity Occupancies ..... 5

    Special Occupancy Requirements ..... 6

        Places of Confinement ..... 6

        Child Care Centers ..... 6

        Museums and Art Galleries ..... 6

        Laboratories ..... 6

        Laboratories in Other Occupancy Buildings ..... 6

        Fire Control Center ..... 6

    Egress Requirements ..... 7

        Travel Distances ..... 7

        Stairs ..... 7

        Exit Discharge ..... 7

        Doors ..... 7

        Fire Escapes ..... 7

    Fireproofing ..... 8

        General Requirements ..... 8

        Sprayed-on Fireproofing ..... 8

**CHAPTER 1. GENERAL REQUIREMENTS**

---

Concealed Sprayed-on Fireproofing .....	8
Exposed Fireproofing.....	9
Fireplaces.....	9
Interior Finishes.....	9
Flame Spread .....	9
Wood Paneling or Other Decorative Materials .....	9
Furring Spaces .....	9
Materials Treated with Fire-retardants .....	10
Draperies and Curtains.....	10
Mechanical Requirements.....	11
Special Requirements for Air-Conditioning Systems.....	11
Cooling Towers.....	11
Main Shut-off of Air Handling System.....	11
Duct Smoke Detectors .....	11
Special Ventilation Systems.....	12
Heating Equipment .....	12
Gas Piping.....	12
Smoke Management.....	12
Fire Suppression Systems.....	13
Water Supply for Standpipes and Automatic Sprinkler Systems.....	13
Fire Pumps .....	13
Standpipes.....	13
Fire Department Hose Outlets.....	14
Fire Hose and Fire Hose Cabinets.....	14
Automatic Sprinkler Systems.....	14
General Sprinkler System Requirements .....	14
Fully Sprinklered Buildings .....	14
Sprinkler Zones .....	15
Quick Response Sprinklers.....	15
Concealed and Recessed Sprinklers .....	15
Sprinkler Flow and Coverage.....	15
Temperature Ratings .....	15
Sprinklers in Spaces Housing Electrical Equipment .....	15
Inspector's Test Connections .....	16

***FACILITIES STANDARDS FOR THE PUBLIC BUILDINGS SERVICE***

---

Pre-action System Requirements .....	16
Chemical Fire Extinguishing Systems .....	16
Dry Chemical System Acceptance Tests .....	17
Wet Chemical System Acceptance Tests .....	17
Halon Extinguishing Systems .....	17
Electrical Requirements .....	18
Power, Emergency Power and Lighting Requirements .....	18
Elevator Systems .....	18
General Requirements.....	18
Shunt Trip .....	18
Recall .....	18
Fire Alarm System.....	18
General Requirements.....	18
Integration of Systems .....	19
Special Fire Alarm System Requirements .....	19
Manual Fire Alarm Stations .....	20
Water Flow Switches .....	20
Heat and Smoke Detectors.....	20
Supervisory Signals .....	20
Trouble Signals .....	21
System Output.....	22
Operation of Manual Fire Alarm, Heat Detector and Water Flow Alarm.....	22
Operation of Smoke Detectors .....	23
Operation of the Supervisory System .....	23
Operation of the Trouble System .....	23
Fire Department Notification .....	23
Operation of Evacuation Alarms.....	24
Operation of Voice Communication Systems .....	24
Power Supply Source.....	24
Survivability.....	25
Testing .....	25
Essential Electronic Facilities .....	26
Construction and Segregation Requirements .....	26
Construction and Finish Materials .....	26
Smoke Detectors .....	26



**CHAPTER 1. GENERAL REQUIREMENTS**

---

Sprinkler Protection .....	26
Smoke and Fire Dampers.....	27
Emergency Shut-off Switches.....	27
Storage Facilities.....	28
Special Design Standards.....	28
Floor Area Limitations .....	29
Storage Arrangements .....	30
General Storage Facilities .....	30
Track Files .....	30
Fire Suppression Systems.....	31
Water Demand .....	31
Fire Pumps .....	31
Automatic Sprinkler Systems.....	31
Fire Detection Systems.....	32
Detectors .....	32
Alterations in Existing Buildings and Historic Structures.....	33
Evaluation of Existing Systems .....	34
Code Requirements for Alterations .....	34
General Design Considerations for Alterations .....	34
Sprinkler Systems .....	34
Sprinkler Coverage .....	35
Sprinkler Layout .....	35
Fire Alarm.....	35

**CHAPTER 8  
SECURITY DESIGN**

General Approach ..... 1

Codes and Standards ..... 3

Basic Security Requirements for GSA Buildings ..... 4

    Building Classifications ..... 4

        Category I ..... 4

        Category II ..... 4

        Category III ..... 5

        Courts ..... 5

        Child Care Centers ..... 5

    Development of Security Design ..... 5

    Basic Security System Choices ..... 6

        Mechanical Key Locks ..... 6

        Electronic Access Controls ..... 6

        Electronic Article Surveillance ..... 6

        Intrusion Detection System ..... 7

        Assessment System ..... 7

        Panic Alarms ..... 7

        Location of Security Devices ..... 7

Site Security ..... 9

    Parking Lots ..... 9

    Lighting ..... 9

Parking Structures ..... 10

    Parking Garages Below Buildings ..... 10

Building Security ..... 11

    Building Entrances ..... 11

        Main Entrance ..... 11

        Employee Entrance ..... 11

        Other Entrances ..... 11

        Egress Doors ..... 12

        Loading Dock Roll-up Doors ..... 12

*CHAPTER 1. GENERAL REQUIREMENTS*

---

Loading Dock Personnel Doors .....	12
Stair Doors Connecting Lobby and Parking Levels.....	12
Stair Doors Connecting Lobby to Upper Floors .....	12
Stair Doors at Upper Floor Level.....	12
Windows .....	12
Other Accessible Exterior Openings.....	13
Building Lobby.....	13
Elevators .....	13
Floor Access .....	13
Room Access .....	14
Support Spaces .....	14
Areas Requiring Special Security Measures .....	15
Spaces Where Cash is Disbursed .....	15
Child Care Centers .....	15
Computer Centers .....	15
Cafeterias .....	15
Libraries .....	15
Security System Design .....	16
General Requirements.....	16
Manufacturer's Certification.....	16
Modular Design .....	16
System Components.....	16
System Integration .....	17
Hardware Locations .....	17
System Zoning .....	17
Software .....	17
Provision for Future System Upgrade.....	17
Security System Devices .....	18
Access Controls .....	18
Mechanical Locks.....	18
Electric Locks.....	18
Card Readers and Key Pads .....	18
Intrusion Detection.....	18
Balanced Magnetic Switches.....	18

***FACILITIES STANDARDS FOR THE PUBLIC BUILDINGS SERVICE***

---

Glass Breakage Detectors .....	18
Motion Detectors .....	18
Assessment.....	19
CCTV .....	19
Panic Alarms .....	19
Duress Alarms .....	19
Signal Communications.....	20
Wired Systems .....	20
Radio Frequency Transmission.....	20
Line Security and Integrity .....	20
Remote Reporting .....	20
Alarm Monitoring Stations and Control	
Centers .....	21
Security Control Center .....	21
Operator Station .....	21
Backup Power.....	22
Alterations in Existing Buildings and Historic Structures.....	23

# **CHAPTER 1**

# **GENERAL REQUIREMENTS**

## **Purpose of the Facilities Standards for the Public Buildings Service**

The *Facilities Standards* set forth product requirements and criteria for new buildings and alterations for the Public Buildings Service of the General Services Administration (GSA).

This document contains policy and technical criteria to be used in the programming and design of GSA buildings. It is intended to be a building standard; it is not a textbook, handbook, training manual or substitute for the technical competence expected of a design or construction professional.

***FACILITIES STANDARDS FOR THE PUBLIC BUILDINGS SERVICE***

---

The *Facilities Standards* should be used with the specific building program for the project, which shows project information such as the housing plan and other special requirements for tenants.

There may sometimes be conflicts between the *Facilities Standards* and specific project requirements. Contact the Director of the Facilities Standards and Technology Division, Office of Design and Construction, Public Buildings Service, General Services Administration, Washington, DC 20405 or call (202) 501-1646 for advice if there is a question on the background of any particular requirement.

This metric version uses the GSA-adopted convention of using only millimeters (mm) on drawings as much as possible so that any number shown in this book without a dimensional suffix is always mm.

Contact the National Institute of Building Sciences, Construction Metrication, Council 1201 L Street, NW., Suite 400, Washington, DC 20004, (202) 289-2800 for a copy of the GSA Metric Design Guide and other metric information.

Arrangement of Chapters

Chapter 1: *General Requirements*

Appendix 1.A: *Life Cycle Cost Example*

Chapter 2: *Site Planning and Landscape Design*

Chapter 3: *Architectural and Interior Design*

Chapter 4: *Structural Engineering (Includes Seismic Design)*

Chapter 5: *Mechanical Engineering*

Chapter 6: *Electrical Engineering*

Appendix 6.A: *Energy Efficient Design of New Buildings*

Chapter 7: *Fire Protection Engineering*

Chapter 8: *Security Design*

Index

## **Applicability of the Facilities Standards**

This book should be used by all professionals engaged in the planning and design of new facilities or alterations for GSA. It applies equally to in-house designers and outside firms and professionals under GSA contract: programmers, architects, planners, landscape architects, engineers, space planners and interior designers.

GSA is charged by law to construct, alter and lease building facilities for many agencies of the Federal Government. Under this mandate, GSA acts both as developer and owner of Federal real estate, while the agencies housed in Federal buildings can be regarded as tenants. GSA receives building authority from the U.S. Congress.

### GSA Building Types

**Office Buildings.** About 80 percent of all GSA buildings are office buildings. Accordingly, the criteria in the *Facilities Standards* are directed most specifically toward the design of office buildings.

**Courts.** In general, the criteria contained in this book apply to all buildings housing U.S. Courts. For more specific design guidelines see the Administrative Office of the United States Courts (AOC) document *U.S. Courts Design Guide*. In case of conflict, the *U.S. Courts Design Guide* takes precedence over the *Facilities Standards*.

**Border Stations.** In general, the criteria contained in this book apply to all border stations. For more specific design guidelines see the *United States Border Station Design Guide (PBS-PQ130)*. In case of conflict, the *United States Border Station Design Guide* takes precedence over the *Facilities Standards*.

**Child Care Centers.** In general, the criteria contained in this book apply to all child care centers. For more specific design guidelines, see the *GSA Child Care Center Design Guide (PBS-PQ140)*. In case of conflict, the *GSA Child Care Center Design Guide* takes precedence over the *Facilities Standards*.

**Other Building Types.** GSA also owns and manages a relatively small number of diverse building types: warehouses, laboratories, archives, libraries, museums and others.



Excluding the specific standards for office space, the criteria listed in this book generally apply to these buildings as well, within the constraints of specific building functions.

### Types of Facilities

**New Construction of GSA Owned Facilities.** The *Facilities Standards* are most specifically written to guide the design of Government owned new construction.

**Repair and Alteration Projects.** The *Facilities Standards* apply to all repair and alteration projects. It is understood that existing conditions may make it impossible to follow all the guidelines exactly. In repair and alteration projects, literal compliance with the criteria is less important than creative efforts to achieve the same end result. A section on repair and alteration projects has been included in each chapter.

**Historic Buildings.** Many GSA buildings are historic: that is, they are included on, or have been determined to be eligible for inclusion on the National Register of Historic Places. In addition, any GSA buildings which are 45 years old or older should be considered likely to be historic even if they have not yet been evaluated for National Register eligibility.

In general, if a building is historic, GSA has developed a Historic Building Preservation Plan (HBPP) which is given to the architects and engineers before design starts to serve as a design guide which will ensure the appropriate treatment and preservation of the building's significant historic spaces, architectural details and systems. The Secretary of the Interior's Standards for Rehabilitation and Illustrated Guidelines for Rehabilitating Historic Buildings (SOI Standards) are embodied in the ratings and recommendations of the HBPP. If an HBPP is not provided at the start of a project, the architects and engineers should contact the Contracting Officer to determine whether one is available. If an HBPP does not exist, architects and engineers are expected to design with professional attention to historic preservation considerations, in keeping with the SOI Standards.

***FACILITIES STANDARDS FOR THE PUBLIC BUILDINGS SERVICE***

---

The HBPP is a comprehensive building report which uses a standardized rating system to identify levels of historic significance of the overall building, zones or areas within the building, and elements within each zone. An element may be an architectural feature, structural component, engineering system or functional requirement. These zone and element ratings provide the standards for the development of all design plans for the building. Other pertinent guidelines, standards and critical documents will be interpreted and integrated into the design based on the ratings established in the HBPP.

GSA utilizes a Building Engineering Report (BER) to plan and budget for the long term retention of its existing properties through inspection and evaluation of each building, its systems, materials and grounds. The BER addresses a building's current condition in order to provide a basis for recommending needed improvements. The BER is also given to the architects and engineers before the design starts. If conflicts or significant differences are found between the HBPP and the BER or any other documents provided by GSA prior to the start of design, the GSA Contracting Officer must be alerted immediately so that these issues can be resolved.

[Reserved]

## **General Design Philosophy**

The following characteristics distinguish GSA buildings from privately owned buildings.

**Design Quality.** GSA is committed to the highest quality of design in the development of its sites and buildings. The statement on *Guiding Principles for Federal Architecture*, drafted by the Assistant Secretary of the Interior in 1962 and reproduced in Figure 1-1, expresses this commitment. GSA buildings are the places where most of the interaction between citizens and Government occurs. Federal buildings express the image of the Government to the public.

**Life Expectancy.** Federal buildings exist for a long time. They need to age well. They should be designed to a level of quality and durability that will endure many decades. Since most GSA buildings remain under the same ownership for their lifetime, expansion potential is an important concern in site, building and systems design.

**Frequent Changes.** Federal buildings undergo many changes during their lifetime. As Government missions change, Federal agencies are created or abolished, or are assigned new tasks. As a consequence, requirements for space and services change frequently, and space must be renovated often. Sometimes a building changes hands from one agency to another. The flexibility to accommodate continual change needs to be "built in" to the building design from the outset and respected in subsequent alterations. Systems flexibility and modular design should become by-words in GSA buildings.

**Cost Effectiveness.** Federal buildings must be cost effective. Since it is the taxpayer who pays the bill, the designer should always ask: "Is there a more cost effective design that will suit the requirements of the project?" This question is equally valid whether it concerns a whole building or a small part of one system. It also reaches across architecture and engineering disciplines. Sometimes a slightly higher expense in one building system results in significant savings in another.

In comparing costs, GSA uses life cycle cost analyses. Under this strategy, both the original tenant fit-up and present value of future alteration costs are considered at the time of the original design in the capital outlay for the building. This method of cost analysis permits the selection of materials and systems based on long term value rather than first cost.

**Building Maintenance.** Building service equipment should be organized to be accessible for maintenance, repair or replacement without causing significant disturbance in occupied space. Ease of operation should be considered when selecting mechanical and electrical equipment.

**Art in Architecture.** As stated in the *Guiding Principles for Federal Architecture* (Figure 1-1), GSA has a policy of incorporating fine art into the design of new Federal buildings and in major repair and alterations of existing Federal buildings. Up to 0.5 percent of the estimated construction costs is reserved for commissioning works by living artists, and these works are acquired through a commissioning process that involves public participation by art professionals, representatives of the community, and the architect of the building. Art and architecture should complement one another; to that end, cooperation between artists and building designers is strongly encouraged.

## ***FACILITIES STANDARDS FOR THE PUBLIC BUILDINGS SERVICE***

---

In the course of its consideration of the general subject of Federal office space, the committee has given some thought to the need for a set of principles which will guide the Government in the choice of design for Federal buildings. The committee takes it to be a matter of general understanding that the economy and suitability of Federal office design space derive directly from the architectural design. The belief that good design is optional, or in some way separate from the question of the provision of office space itself, does not bear scrutiny, and in fact invites the least efficient use of public money.

The design of Federal office buildings, particularly those to be located in the nation's capital, must meet a two-fold requirement. First, it must provide efficient and economical facilities for the use of Government agencies. Second, it must provide visual testimony to the dignity, enterprise, vigor and stability of the American Government.

It should be our object to meet the test of Pericles' evocation to the Athenians, which the President commended to the Massachusetts legislature in his address of January 9, 1961: "We do not imitate -- for we are a model to others."

The committee is also of the opinion that the Federal Government, no less than other public and private organizations concerned with the construction of new buildings, should take advantage of the increasingly fruitful collaboration between architecture and the fine arts. With these objects in view, the committee recommends a three point architectural policy for the Federal Government.

1. The policy shall be to provide requisite and adequate facilities in an architectural style and form which is distinguished and which will reflect the dignity, enterprise, vigor and stability of the American National Government. Major emphasis should be placed on the choice of designs that embody the finest contemporary American architectural thought. Specific attention should be paid to the possibilities of incorporating into such designs qualities which reflect the regional architectural traditions of that part of the Nation in which buildings are located. Where appropriate, fine art should be incorporated in the designs, with emphasis on the work of living American artists. Designs shall adhere to sound construction practice and utilize materials, methods and equipment of proven dependability. Buildings shall be economical to build, operate and maintain, and should be accessible to the handicapped.

2. The development of an official style must be avoided. Design must flow from the architectural profession to the Government, and not vice versa. The Government should be willing to pay some additional cost to avoid excessive uniformity in design of Federal buildings. Competitions for the design of Federal buildings may be held where appropriate. The advice of distinguished architects ought to, as a rule, be sought prior to the award of important design contracts.

3. The choice and development of the building site should be considered the first step of the design process. This choice should be made in cooperation with local agencies. Special attention should be paid to the general ensemble of streets and public places of which Federal buildings will form a part. Where possible, buildings should be located so as to permit a generous development of landscape.

### **Figure 1-1 Guiding Principles for Federal Architecture**

## Codes and Standards

GSA has adopted several codes and standards that govern Federal construction throughout the United States and its territories.

### Building Codes

Except as noted below, GSA will use one of the three national model building codes for each project. The particular code used will vary with geographic location. The project team will be given a copy of the latest GSA order on code compliance at the project inception or A/E selection.

For egress requirements, the provisions of the National Fire Protection Association (NFPA) Standard 101 Life Safety Code shall be followed in lieu of the egress requirements of the national model building code used.

All electrical work will follow the provisions of the National Electric Code, issued by the NFPA.

**Editions of National Codes.** The latest edition of each code in effect at the time of design contract award must be used throughout the project's design and construction.

**Conflicts between Codes and GSA Requirements.** It is GSA policy to make maximum use of equivalency clauses in all the codes to ensure flexibility. If there is a conflict between a code requirement and a GSA requirement, the GSA requirement will prevail.

**Deviations from Building Code Provisions.** The Mandatory Design Standards listed below take precedence over the provisions of the building codes. Additional, specific deviations from codes are discussed in the chapters of the book where they apply.

**Local Building Codes.** GSA has an established policy to comply with local building codes to the greatest extent possible. Local and/or State officials will be given the opportunity to review GSA projects for compliance with local requirements. Comments from local jurisdictions will be carefully considered, but GSA has the final authority to accept or reject any comment.

Legally, buildings built on Federal property are exempt from local building codes. In case of buildings developed on private land to be leased to GSA, however, the applicable local codes govern instead of the codes adopted by GSA.

Local jurisdictions have the option of performing construction inspections to verify code compliance. If they elect to do so, special provisions will be included in the architect/engineer's (A/E's) and contractor's contracts to handle the additional requirement of coordinating their work with local authorities.

**Code Requirements for Alterations.** Generally, the building systems need only be upgraded to correct deficiencies identified by GSA, unless the entire building is being renovated. However, any existing condition identified as less safe than it was before modification should be corrected. All new work should meet codes. Where questions arise, they should be discussed with the designated code reviewer of the GSA region responsible for the project.

**Zoning Ordinances.** The Public Buildings Act Amendments of 1988 require that GSA consider local zoning and other planning requirements to the maximum extent practical. Regional GSA staff and A/E's must consult with local officials and provide them the opportunity to review the concept design of a new facility or addition for zoning compliance. The comments must be treated as recommendations and carefully considered; however, GSA has the final authority to accept or reject any comment.

In the case of leased facilities built on private land, all local zoning ordinances apply.



## Mandatory Design Standards

**Accessibility Standards.** Federal Standard 795: Uniform Federal Accessibility Standards is mandatory on all GSA projects. Current GSA policy requires compliance with the requirements of Title III Standards for the Americans with Disabilities Act where those requirements are stricter than Federal Standard 795. This policy will remain in effect until the Uniform Federal Accessibility Standards have been updated and reissued.

The criteria of these standards should be considered a *minimum* in providing access to the handicapped. Where dimensions for clearances are stated, allowance should be made in the design for construction tolerances to ensure the finished construction is in full compliance.

It is GSA policy to make all Federal buildings accessible to the handicapped without the use of special facilities for the disabled. The intent of this policy is to use standard building products set at prescribed heights and with prescribed maneuvering clearances to allow easy use by disabled employees and visitors. Building elements designated specifically for use by the handicapped should be kept to a minimum.

Both the Uniform Federal Accessibility Standards and the Title III Standards for the Americans with Disabilities Act permit modification of standard approaches to provide accessibility when implementation of such approaches would damage the fabric of a historic property.

**Conflicts with Historic Preservation.** In cases of apparent conflict between requirements such as those for accessibility, asbestos removal, seismic performance, and landscaping and the preservation of significant historic fabric, the architects and engineers shall notify the Contracting Officer so that the issue can be addressed explicitly and early in the project.

**Energy Conservation Standards.** The governing energy design standard is the Department of Energy Standard 10 CFR, Part 435 Energy Conservation Voluntary Performance Standards for Commercial and Multi-Family High Rise Residential Buildings; Mandatory for New Federal Buildings; Interim Rule. GSA has adopted the latest edition of ASHRAE/IES Standard 90.1 Energy Efficient Design of New Buildings Except Low-Rise Residential Buildings, published by the American Society of Heating, Refrigerating and Air-Conditioning Engineers, Inc., for energy conservation, with the two amendments that follow:

***FACILITIES STANDARDS FOR THE PUBLIC BUILDINGS SERVICE***

---

1. Since it is an industry standard, ASHRAE/IES 90.1 typically uses the verbs "recommended," "suggested," etc. Any text phrased as a recommendation in the Standard will be understood as a mandatory requirement.
2. Performance requirements designated as taking effect in 1992 will be understood to be current requirements.

The performance of buildings designed according to ASHRAE 90.1 will be equivalent to those designed to 10 CFR 435.

For alteration work in existing buildings, the following standards published by the American Society of Heating, Refrigerating and Air-Conditioning Engineers (ASHRAE) apply:

ASHRAE Standard 100.3: Energy Conservation in Existing Buildings.

ASHRAE Standard 100.5: Energy Conservation in Existing Buildings - Institutional.

ASHRAE Standard 100.6: Energy Conservation in Existing Buildings - Public Assembly.

#### Compliance with the National Environmental Policy Act

GSA conducts an environmental review of each project prior to the start of design to identify environmental impacts as required by the National Environmental Policy Act (NEPA). The review can result in:

- The preparation of an Environmental Assessment with issuance of a Finding of No Significant Impact (FONSI), or
- The preparation of an Environmental Assessment that identifies significant impacts, followed by preparation of an Environmental Impact Statement (EIS), or
- The preparation of an EIS.

If an Environmental Assessment or EIS has been prepared, it will constitute the primary guideline for environmental design issues. In those instances where GSA has committed to implementing specific mitigation measures, programmers and designers must ensure that those measures are carried out in the design. The following documents may contain specific design requirements or may influence design decisions:

***FACILITIES STANDARDS FOR THE PUBLIC BUILDINGS SERVICE***

---

Council of Environmental Quality (CEQ), Code of Federal Regulations (CFR) Title 40, Parts 1500 - 1508: Regulations for Implementing the National Environmental Policy Act.

GSA ADM 1095.1D: Environmental Considerations in Decision Making.

PBS P 1095.4B: Preparation of Environmental Assessments and Environmental Impact Statements.

GSA ADM 1095.2: Considerations of Flood Plains and Wetlands in Decision Making.

GSA PBS IL-92-8: Real Property Management and Safety Policy Handbook.

Environmental Protection Agency (EPA), 10 CFR 40, 1.23, 1-4, 1-16: Procedures for Implementing the Clean Air Act and the Federal Water Pollution Control Act.

EPA, 40 CFR 50: National Primary and Secondary Ambient Air Quality Standards.

EPA, 40 CFR 60: New Source Performance Standards.

EPA, 40 CFR 61: National Emission Standards for Hazardous Air Pollutants.

EPA, 40 CFR 82: Protection of Stratospheric Ozone.

EPA, 40 CFR 260-299: Solid Wastes.

EPA, 40 CFR 300-399: Superfund, Emergency Planning and Community Right-to-Know Programs.

EPA, 40 CFR 401-403: Effluent Guidelines and Standards.

## Environmental Policies

### Building Materials

**Prohibited Materials.** The use of the following materials is prohibited on all GSA projects:

- Products containing asbestos.
- Products containing urea formaldehyde.
- Products containing polychlorinated biphenyls.
- Solder or flux containing more than 0.2 percent lead and domestic water pipe or pipe fittings containing more than 8 percent lead.
- Paint containing more than 0.06 percent lead.

**Lead-Based Paint in Alteration or Demolition Projects.** When alteration or demolition requires sanding, burning, welding or scraping painted surfaces, test the paint for lead content. When lead is found, implement the controls required by OSHA in 29 CFR 1926.62. Do not abate lead-based paint when a painted surface is intact and in good condition, unless required for alteration or demolition. In child care centers, test all painted surfaces for lead and abate surfaces with lead-based paint.

**Recycled Materials.** EPA guidelines require the use of recovered materials in federally funded construction. Architects and engineers should use recycled materials (fly ash and building insulation, see below) to the maximum extent practical within the project requirements. If recycled materials are inappropriate, designers should document the reasons within the project design analysis.

Fly ash should be used to replace up to 20 percent of portland cement in concrete mix designs.

It is recommended that building insulation have a minimum content of recovered material as indicated in Table 1-1. If the specified amount of recycled material is not available for a given product, a lesser percentage is acceptable. These requirements do not apply to acoustic insulation, insulation used in plumbing or HVAC systems or fireproofing.

Table 1-1  
**Minimum Content of Recovered Material for Insulation**

<u>Material Type</u>	<u>Percent by Weight</u>
Cellulose loose fill and spray-on	75
Perlite composite board	23
Plastic rigid foam, polyisocyanurate or polyurethane	9
Foam-in-place polyisocyanurate/polyurethane	5
Reinforced glass fiber	6
Phenolic rigid foam	5
Rock wool	75

#### Abatement of Asbestos in Existing Buildings

Prior to alteration design, an evaluation is performed on all existing buildings. This evaluation should include review of inspection reports and a site inspection. If asbestos damage or the possibility of asbestos disturbance during construction activity is discovered, one of the following four corrective actions must be taken: removal, encapsulation, enclosure or repair. The assessment must be performed by appropriately trained inspectors.

**Design.** All design drawings and specifications for asbestos abatement must be produced by a qualified specialist. The guiding standards for this work are the GSA PBS IL-92-8 and OSHA and EPA regulations, in particular 29 CFR 1926.58, 40 CFR 61.140-157 and 49 CFR 171-180. The design must be approved by the regional Safety and Environmental Management Branch of GSA. In general, projects should be designed to avoid or minimize asbestos disturbance. The environmental standards will be supplied by the regional office of GSA.

**Construction.** All GSA work that disturbs asbestos must be performed using appropriate controls for the safety of workers and the public.

**Inspections.** Regular inspection of the abatement work area and surrounding areas should be performed on behalf of GSA to protect the interests of GSA, the building occupants and the public. Such inspections should include visual and physical inspection and air monitoring by phase contrast microscopy and/or transmission electron microscopy, as appropriate. Inspections should be performed under the supervision of a Certified Industrial Hygienist, Registered Architect or Professional Engineer by individuals accredited under the Asbestos Hazard Emergency Response Act (AHERA) for asbestos abatement supervision.

**Laboratories.** Laboratories analyzing samples for asbestos must be accredited by the American Industrial Hygiene Association (AIHA) or the National Institute for Standards and Technology's Voluntary Laboratory Accreditation Program. Laboratories analyzing air samples by phase contrast microscopy must have demonstrated successful participation in the National Institute for Occupational Safety and Health (NIOSH) Proficiency in Analytical Testing program for asbestos.

On-site analysis by phase contrast microscopy may be performed as required, provided that the analyst is board-approved in the AIHA Asbestos Analysis Registry and provided that a quality assurance program is implemented, including recounting of a fraction of samples by a qualified laboratory. All final clearance transmission electron microscopy air samples must be analyzed in accordance with the EPA AHERA protocol in 40 CFR 763, Appendix A of subpart E.

## Radon Mitigation

**New Construction.** If the potential for radon release is identified in the geotechnical report (see GSA document *Submission Requirements for Design and Construction (PBS-PQ280)*), measures should be taken in the building design to keep radon levels below the lowest level identified by the EPA that would require remedial action.

**Alterations.** In existing buildings radon levels should be tested if alterations cause changes in areas with slabs or walls in contact with the ground. GSA will advise the A/E if current or previous radon readings have exceeded the lowest EPA action level.

**Design Considerations.** The EPA is currently working on a draft document outlining construction methods to reduce radon hazard in buildings. Until this document is published, designers will need to rely on professional judgment for the design of mitigating measures. Ideas to consider include:

- Sealing of construction, expansion and seismic joints in slabs on grade.
- Sealing of all penetrations in foundation walls.
- Placement of a vapor barrier under slab on grade. All penetrations through the vapor barrier should be sealed.
- Ventilating of crawl spaces.
- Installation of a sub-slab depressurization system, which consists of a grid of perforated pipe placed in the gravel layer below the vapor barrier and vented to the outside air.

If so, GSA will provide data which will permit an analysis of likely future radon levels by the A/E. Based on this analysis, mitigation features should be incorporated into the design with the goal of protecting occupants from radon emissions at or above the lowest action level identified by the EPA.



## Submission Requirements

Architectural and engineering design submission requirements for new construction and alterations are described in the GSA document *Submission Requirements for Design and Construction (PBS-PQ280)*. This document also contains information on drawings, specifications, calculations and narratives, and states requirements for surveys and geotechnical reports.

### Specifications Requirements

**Technical Requirements for Specifications.** Federal Acquisition Regulation (FAR) 10.004, Selecting Specifications or Description for Use, specifically addresses specifications and requires that they be non-proprietary. The basic reason for this is to ensure competition, and to prevent abuse, both within the Government and by those under contract with the Government. While A/E's under contract to GSA have a great deal of latitude in the design of buildings and types of products they can specify, they may not exercise that latitude in the method of proprietary specifying as they would in the private sector. A/E's must be aware of and adhere to the restrictions and limitations that regulations impose on construction specifications and develop a project specification that meets GSA needs.

The requirement for non-proprietary specifications applies to every GSA project in which GSA, as an owner, enters into a contract with a construction contractor. It does not apply to existing facilities purchased or leased by GSA in a completed condition, or to alterations to leased facilities which are contracted for by the lessor rather than the Government.

GSA/PBS furnishes its regional offices with the Construction Criteria Base (CCB) informational disk medium which is also available from the National Institute of Building Sciences, Washington, DC. (The CCB contains American Institute of Architects (AIA) Masterspec, Naval Facilities Engineering Command, U.S. Army Corps of Engineers, Department of Veterans Affairs, and National Aeronautics and Space Administration guide specifications, which can be used to develop project specifications.)

***FACILITIES STANDARDS FOR THE PUBLIC BUILDINGS SERVICE***

---

The use of any guide specification does not relieve the A/E of design responsibility. It is the designer's responsibility to edit any specification to reflect the project design intent, GSA policy requirements, and Federal law. Material in these specifications is not policy. All GSA policy and criteria applicable to project design and systems selection are contained in the *Facilities Standards* (and similar handbooks, such as the *United States Border Station Design Guide (PBS-PQ130)*, *GSA Child Care Center Design Guide (PBS-PQ140)*, and the AOC document *U.S. Courts Design Guide*).

Specifications must be carefully coordinated with drawings to ensure that everything shown on the drawings is specified. Specification information not applicable to the project should be deleted. It is important to note that, for GSA projects, specifications always take precedence over drawings in case of conflict. This is the reverse of what may be customary in private practice.

## Life Cycle Costing

Life cycle costing is an important analysis used in the selection of systems that generate significant operating costs and/or replacement costs.

In designs for new buildings and alterations, life cycle cost analyses should be performed to assist in the selection of various systems, as required in the A/E's scope of work. An example of an HVAC life cycle cost analysis is provided in Appendix 1.A., *Life Cycle Cost Example*.

### Cost Elements

The life cycle cost analysis should use present value calculations, in accordance with the Code of Federal Regulations (CFR), Title 10, Part 436, Subpart A: Program Rules of the Federal Energy Management Program.

It is important to note that present value calculations are only meaningful for design decision comparisons. Present value costs should never be used to make budgetary projections of actual costs.

**Notation.** The following terms are used within present value life cycle cost formulae:

$FV$  = future value

$PV$  = present value

$TV$  = today's value

$d$  = real discount rate

***FACILITIES STANDARDS FOR THE PUBLIC BUILDINGS SERVICE***

---

$e$  = real growth escalation rate (the differential escalation rate that exists after removing the influence of general inflation)

$n$  = number of years to occurrence or the analysis period, as appropriate

**Sunk Costs.** Sunk costs are those already incurred or irrevocably committed. Examples are design and construction work already started or completed.

**First Costs.** These costs are typically estimated at today's value. They can include costs for site acquisition, surveys, special design related fees, demolition of existing construction, alterations and repairs, costs for new construction, and construction supervision.

**Non-recurring Future Costs.** Examples of these are major replacement costs, non-annual maintenance/repair and major alterations to existing work.

The present value of non-recurring future costs can be treated by escalating a known (today's value) to its future value using a real growth escalation rate, then discounting that

$$FV = TV(1 + e)^n$$

future value to present value. Escalate the known today's value to future value in constant dollars as follows:

$$PV = \frac{FV}{(1 + d)^n}$$

Then discount the future value back to present value:

The term  $1/(1 + d)^n$  is known as the Single Present Worth (SPW) factor and is tabulated in Appendix A-1 of the latest *Energy Prices and Discount Factors for Life Cycle Cost Analysis* published by the National Institute of Standards and Technology (NIST).

$$PV = TV \left( \frac{(1+e)^n}{(1+d)^n} \right)$$

**Combined Procedure.** To combine both procedures, use:

**Uniform Annually Recurring Constant Dollar Costs.** These involve costs that are influenced by general inflation but have negligible real growth, such as fixed payment service contracts with an inflation adjustment clause, preventive maintenance, scheduled minor replacements and annually recurring costs that increase in price at the same rate as general inflation. The present value of such costs can be determined by the Uniform

$$PV = TV(UPW)$$

Present Worth (UPW) formula:

$$UPW = \frac{(1+d)^n - 1}{d(1+d)^n}$$

Where

The UPW factor is tabulated in Appendix A-2 of the previously referenced NIST publication, *Energy Prices and Discount Factors*.

**Annually Recurring Costs.** Annually recurring costs that escalate in real value are usually associated with cost elements such as service or maintenance, which involve increasing amounts of work and/or an escalation in cost different from general inflation. They may also consist of fuel costs or costs of frequent replacements that escalate at a rate different from general inflation.

$$PV = TV(UPW^*)$$

The present value of such costs are calculated by using the following modified version of the *UPW* formula (*UPW\**) which allows for cost escalation:

$$UPW^* = \frac{[(1+e)/(1+d)]^n - 1}{1 - (1+d)/(1+e)}$$

Where

and *e* is constant over *n*.

$$UPW^* = \left( \frac{1+e}{d-e} \right) \left( 1 - \left( \frac{1+e}{1+d} \right)^n \right)$$

Another representation is:

**Recurring Fuel Costs.** These can be represented in present value by employing a modified *UPW\** factor that takes into account multiple escalation rates. Energy related *UPW\** factors are found in Appendices B-1a through B-4a of the referenced NIST

$$PV = TV(UPW^*)$$

publication, arranged by regional location, billing sector (e.g., commercial), fuel type and analysis period. The formula to be applied is:

Generally, *TV* of fuel costs can be calculated simply by multiplying the annual quantity of fuel times the local fuel pricing charged by the utility at the start of the study. Electric demand charges can be assumed to escalate at the same rate as shown in *UPW\** tables for electricity consumption unless actual escalation rates for demand are provided by the local utility.

#### Procedures and Approach

**Defining Alternates.** When defining alternates for life cycle costing, an acceptable level of overall building service must be assured throughout the analysis period. Costs which are common to all options may be ignored.

**Comparison of Design Alternates.** Design alternates should be compared against a baseline reference option. The baseline cost must offer a viable system employing state-of-the-art design options and support affected service functions.

Where existing conditions will form part of the baseline, the analysis should include the additional costs necessary to achieve code compliance, all repair and alteration work, and all costs necessary to ensure reliable operation. Generally, the criteria stated in the *Facilities Standards* should serve as input parameters.

**Analysis Period.** The analysis period should be chosen to fully represent all costs. All options should be considered over the same analysis period.

Where possible, the analysis period should be the smallest whole multiple of the service lives for the major systems involved in the analysis. (Example: with Option A, a service life of 2 years is expected before replacement, with Option B a life of 3 years is anticipated; the smallest whole multiple is 6 years.) Life expectancies may be obtained from manufacturers or from ASHRAE: *HVAC Applications Handbook*. Also see the discussion on residual service worth, which follows.

The analysis period should not exceed 25 years for equipment, in accordance with Department of Energy analysis procedures. The analysis period for structural components or other non-energy related systems can be 30 years to match the prospectus analysis.



**First Costs.** Baseline and alternate first costs are typically those estimated for the construction award date. The life cycle cost analysis would assume that first cost occurrence is at "time-zero" in the analysis period, with all the other event times referenced to the construction award date.

Basing the first cost estimates (and the beginning of the analysis period) on a date other than the construction award date is not required unless directed by GSA. Additional first cost issues should be considered for repair and alteration life cycle cost analyses:

All costs that must be incurred during the lead time, regardless of which retrofit option is adopted, should be deemed sunk and excluded from the analysis of both the baseline case and retrofit option.

All deferrable lead time costs that are avoidable if the retrofit option is adopted should be included as a cost for the baseline case but not for the retrofit option.

To simplify this analysis, the lead time can be compressed and avoidable costs for the baseline can be assumed to occur at the start of the analysis period as with the investment cost of the retrofit option; however, all future planned year projections of investment and replacement cost occurrence must be adjusted to correspond to the length of the lead time period.

For mutually exclusive options where lead time results in significant differences in cost avoidance, a more rigorous analysis should be provided that reflects the lead time. This may result in the discounting of estimated first costs.

**Future Cost Projections.** Constant value is established by escalating a "today's value" using a real growth escalation rate. That constant dollar future cost must be discounted with a real growth discount rate to a present value in "constant dollars."

When converting actual cash flow escalation rate projections (also referred to as budgetary

$$E = e + I + eI$$

or nominal rates) to an escalation rate in real terms (without inflation), the following

$$e = \frac{1 + E}{1 + I} - 1$$

formula applies:

or

Where  $E$  = Budgetary escalation

$e$  = Real growth escalation

$I$  = Inflation rate

$$e = \frac{1 + 0.15}{1 + 0.10} - 1$$

Hence, to convert a given budgetary escalation rate of 15 percent to real terms, allowing, for example, 10 percent inflation, real growth escalation would be:

for  $e = 0.0454$  or 4.54%

**Changing Cost Relationships.** Investment and replacement costs directly associated with providing continued building service should be taken into account for both baseline and alternate options. However, to simplify the analysis, all recurring savings may be assumed to remain proportionate to the initial cost savings differential between the baseline and alternate options.

**Residual Service Worth.** For instances where either the baseline or alternate has service life beyond the analysis period, an allowance shall be made for the associated residual service worth. This calculation should identify the residual constant dollar value at the end of the analysis period, which is then discounted to its present value.

**Analysis Presentation.** Either a manual format or a computer model may be used. Whichever approach is chosen, it must be applied consistently for all alternatives considered. In all cases, the analysis should show:

- Savings to Investment Ratio (SIR): the ratio of the present value savings of an alternate to its increase in present value implementation costs.
- Net Savings (NS): the difference in total life cycle cost between the baseline and a concept alternate.

For energy retrofit projects, also calculate the following:

- The Energy Savings to Investment Ratio (ESIR): the ratio of the annual source energy savings in KW to initial investment cost in dollars.
- The Energy Cost Savings Ratio (ECSR): the ratio of present value energy savings to the initial investment cost.

For each design option, life cycle elements should be summarized in the format shown. Back-up calculation sheets must be in an orderly format.

**Computer Programs.** A computer life cycle cost program that will satisfy GSA requirements is available from NIST.

The NIST Building Life-Cycle Cost computer program (BLCC 3.03) provides an economic analysis of proposed investments that are expected to reduce long-term operating costs of buildings or building systems. It is especially useful for evaluating the costs and benefits of energy conservation projects in new or existing public buildings. Two or more alternative designs can be compared to determine which has the lowest life-cycle cost. Economic measures, including net savings, savings-to-investment ratio and adjusted internal rate of return can be calculated for any design alternative relative to the designated base case.

BLCC 3.03 supersedes both the Federal Building Life-Cycle Cost (FBLCC) and the NIST Life Cycle Cost (NBSLCC) programs. For the economic analysis of energy investments in Federal buildings, BLCC complies with the following:

Office of Management and Budget (OMB) Circular A-94, Discount Rate to Be Used in Evaluating Time-distributed Costs and Benefits.

American Society for Testing and Materials (ASTM), Standard E964: Practice for Measuring Benefit-to-Cost and Savings-to-Investment Ratios for Buildings and Building Systems.

ASTM Standard E917: Practice for Measuring Life-Cycle Costs of Buildings and Building Systems.

ASTM Standard E1057: Practice for Measuring Internal Rates of Return for Investments in Buildings and Building Systems.

ASTM Standard E1074: Practice for Measuring Net Benefits for Investments in Buildings and Building Systems.

The NIST program, BLCC 3.03, was used in the sample Life Cycle Cost Analysis in Appendix 1.A.

**Sensitivity Analysis.** A sensitivity analysis is recommended whenever the assumptions may be considered questionable. Multiple analyses, using extremes of the cost parameters in question, should be used to establish a useful mathematical range.

**Interpretations.** Due to possible margins of error, a cost differential of less than 10 percent may be considered inconclusive by GSA. In this case GSA will decide jointly with the A/E which systems to select.

**Systems Selection.** In systems selection, factors other than cost may be considered overriding, such as occupancy considerations or safety or reliability concerns.

## APPENDIX 1.A

### Life Cycle Cost Example

#### Life Cycle Cost Summary

For this example, a Life Cycle Cost (LCC) Analysis was performed for a hypothetical office building in Kansas City, Missouri, using National Institute of Standards and Technology Building Life Cycle Cost program (Version 3.03). A commercially available energy analysis program was utilized to project energy usage of the various mechanical and architectural system alternates.

#### References

The following references were used for the energy analysis and life cycle cost study:

*Facilities Standards for The Public Buildings Service.*

*FACILITIES STANDARDS FOR THE PUBLIC BUILDINGS SERVICE*

---

Department of Energy (DOE), Code of Federal Regulations (CFR), Title 10 Part 435, Energy Conservation Voluntary Performance Standards for Commercial and Multi-Family High Rise Residential Buildings; Mandatory for New Federal Buildings; Interim Rule.

American Society of Heating, Refrigerating and Air-Conditioning Engineers (ASHRAE), Standard ASHRAE/IES 90.1 Energy Efficient Design of New Buildings Except Low-Rise Residential Buildings.

DOE, CFR, Title 10 Part 436, Subpart a: Program Rules of the Federal Energy Management Program.

NBS Handbook 135, Life Cycle Cost Manual for the Federal Energy Management Program.

Annual Supplement to NBS Handbook 135, Energy Prices and Discount Factors for Life Cycle Cost Analysis.

National Institute of Standards and Technology, Building Life-Cycle Cost (BLCC) Computer Program (Version 3.03, 1990.

ASHRAE Handbooks and Standards.

Kansas City Power and Light Co., Electric Rate Schedule 1-GL (Power and Demand).

Kansas City Power and Light Co., Gas Schedule LCM.

Kansas City Water and Pollution Control Department, Commercial Water Rate.

### The Sample Building

The hypothetical building used in the study is a five-story 23 225 m<sup>2</sup> Federal office building. The approximate plan dimensions are 61 m by 76 m yielding a floor plate of 4 645 m<sup>2</sup>. The floor to floor height is 4 115 mm.

The architectural schematic design calls for a combination of brick and glass exterior skin, with glazing taking up about 40 percent of the total surface area. The roof is a flat concrete slab roofed with a single-ply roofing membrane.

### Mechanical and Architectural Systems Alternates

The following system and equipment alternates were evaluated with regard to energy efficiencies, first costs, maintenance costs, financial factors, utility rate structures and utility inflation rates. The various alternatives were estimated for life cycle cost using the present-worth discounting approach.

#### **Alternate #1: (Base System)**

**Mechanical:** Chilled water/hot water variable volume air handling systems with hot water perimeter heating.

Air handling units (AHU's): Two factory custom AHU's with supply fans, return fans, heating coil, cooling coil, pre-filter and final filter section. AHU fans with variable speed drives.

Ductwork: Medium velocity (15 m/s maximum) for supply ducts from AHU to volume boxes and low velocity (9 m/s maximum) for supply ductwork downstream from volume boxes and for all return and exhaust ductwork.

Chillers #1 and #2: Standard min cop = 5.4 machines. Secondary pumping has variable speed drives with two-way valves on cooling units.

Boiler: Standard gas fired tube boiler.

**Architectural:**

Walls are brick veneer over gypsum sheathing, R-2 (1.94 m<sup>2</sup> K/W) insulation.

Window glass is gray tinted double insulating glass. Coverage of glazing is 40 percent of skin. Roof is 90 mm concrete slab with rigid R-3.5 (3.52 m<sup>2</sup> K/W) insulation and single-ply membrane cover.

**Alternate #2:**

Mechanical:

Same as Alternate #1, except that AHU's are outdoor roof type units with a self-contained refrigeration package, including screw compressors and evaporative pre-cooling.

Architectural:

Same as Alternate #1.

**Alternate #3:**

Mechanical:

Same as Alternate #1, except 10 packaged self-contained VAV interior units (2 per floor) and perimeter heat pumps are used in lieu of VAV custom air handling units, VAV boxes and perimeter radiant heating units.

Architectural:

Same as Alternate #1.

**Alternate #4:**

Mechanical:

Same as Alternate #1.



Architectural:

Same as Alternate #1, except that R-2 (1.94 m<sup>2</sup> K/W) insulation is used in walls in lieu of R-11.

Energy Analysis

A sophisticated commercial computer program was used that is capable of hourly simulation of energy consumption.

Input parameters were the following:

**Temperature/Humidity Data**

	<b>Summer</b>	<b>Winter</b>	<b>Source</b>
Condition	2.5%	1%	ASHRAE
Outdoor Temperatures	350C/230C	170C/-40C	ASHRAE
Indoor	250C	210C	Chapter 5, Table 5-1
Humidity	50% RH	30% RH	Chapter 5, Table 5-1
Unoccupied Temperature	300C	180C	Engineering Judgment
Heating Degree Days C0 days/year with base temperature of 18.30C		2 600	ASHRAE Systems and Fundamentals

**Other Input Parameters**

**People**

Perimeter Space	11.5 m <sup>2</sup> (net)/person	Chapter 3
Interior Space	11.5 m <sup>2</sup> (net)/person	Chapter 3

**Electrical Loads**

Lighting Loads	21.5 W/m <sup>2</sup>	Chapter 6
Miscellaneous Loads	21.5 W/m <sup>2</sup>	Chapter 6

***FACILITIES STANDARDS FOR THE PUBLIC BUILDINGS SERVICE***

---

**Building Envelope**

	<b>U-Value</b>	<b>Shading Coefficient</b>	<b>Source</b>
Roof	.28 W/m <sup>2</sup> k	N.A.	Schematic Design (meets ASHRAE 90.1)
Walls	.45 W/m <sup>2</sup> k	N.A.	Schematic Design (meets ASHRAE 90.1)
Windows	.95 W/m <sup>2</sup> k	.58	Schematic Design (meets ASHRAE 90.1)

**Building Ventilation**

Outside Air	10 L/s = 15 000 L/s total	ASHRAE 62
Infiltration	.25 air changes/hour	Calculated in accordance with ASHRAE fundamentals

**Domestic Hot Water**      3.8 L/person/day      Calculated in accordance with ASHRAE 90.1

**Operating Hours**      7:00 am to 6:00 pm      Chapter 5

**Building Floor Area**      4 645 m<sup>2</sup> (gross)      Schematic Design

**Life Cycle Cost Study Input Parameters**

Study Life	25 years	(Maximum permissible)
Study Date	September 1991	(Actual date of study)
Constr. Midpoint:	December 1993	(Assumed date)
Occupancy Date	: January 1995	(Assumed date)
Discount Factor:	4.7%	(Built into BLCC program)
Electric Rate:	1.30¢/MJ	(From Kansas City Rate Schedule)
Demand Rate:	1.32¢/MJ	
Natural Gas Rate:	1.046¢/MJ	(From Kansas City Rate Schedule)
Demand Rate:	2.544¢/MJ	
Energy Escalation Rate:		
Non-Energy Escalation Rate:	4%	(From Cost Consultant)

**Maintenance Costs:**

3 170 kW chiller	\$6,000	(Service contract data from manufacturers and engineering judgment)
1 585 kW chiller	\$4,000	
94 400 L/s AHU	\$5,000	
17.6 kW heat pump	\$250	
3.5 kW pump	\$100	
VAV terminal	\$130	

***FACILITIES STANDARDS FOR THE PUBLIC BUILDINGS SERVICE***

---

Equipment Life:

Chillers	25 years	From ASHRAE <i>HVAC Systems and Applications</i> 1987
Fin tube radiators	40 years	
AHUs	40 years	
VAV terminals	15 years	
Compressors	15 years	
Pumps	15 years	
17.6 kW heat pump	8 years	
3.5 kW heat pump	8 years	
176 kW VAV A/C unit	15 years	
Condenser coils	20 years	

LCC General Assumptions

All equipment in the life cycle cost analysis was considered to contribute KW demand to the peak KW demand. Off peak demands were not included.

**Life Cycle Cost Results**

The computer run of the NIST BLCC 3.03 program produced the results tabulated in Table 1.A-1. Alternate #4 was shown to have the lowest life cycle cost calculated at present worth.

The total first cost was calculated to be \$3,289,734, and the present value energy cost was calculated to be \$3,215,089. The present value of all maintenance cost was calculated to be \$329,101, and the total life cycle cost was calculated to be \$6,945,338.

**Table 1.A-1  
Results of Life Cycle Cost Analysis**

Al- ter- nate	Description	Present Value First Cost	LCC Present Worth	Net Sav- ings	Savings to Invest- ment Ra- tio
1	VAV w/ Boiler and Chiller and perimeter radiation	\$3,289,734	\$6,945,338	0	N.A.
2	Rooftop VAV w/ perimeter radiation	\$2,986,337	\$7,508,076	-\$562,738	-2.86
3	Packages VAV w/ perimeter heat pump	\$2,634,577	\$8,942,877	-\$1,997,539	-4.05
4	Alt #1 w/ R-19 wall insulation	\$3,309,220	\$6,858,331	\$87,007	5.47

### Recommendation

Alternate #4 is the recommended option. It has been shown to produce the lowest life-cycle cost and will suit the operational requirements of the sample project.

### Energy Analysis Summary

For Alternative #4, which proved the most life cycle cost effective for the HVAC system selection, the energy budget is 2 338.15 kW/m<sup>2</sup>/yr for the sample building.

This analysis was not associated with an energy conservation project. Therefore, the Energy Savings to Investment Ratio (ESIR) and the Energy Savings Cost Ratio (ESCR) were not determined.

### Sample Worksheets

The following two pages show life cycle cost analysis worksheets to be used for manual calculations. The second sheet also shows the figures derived from the computer analysis.

**LIFE CYCLE COST ANALYSIS**

Building Name:			Building No:		
Project Name:			Project No:		
Concept Title:					
Analysis Period:            Years				Real Disc. Rate:	
Energy Savings (z):			MBTU/YR.		Building Energy Use:    KJ/SM/YR.
	<b>Cost Elements</b>	<b>Baseline</b>	<b>Alternate</b>		<b>Difference</b>
a.	Construction Cost				
b.	Contingencies				
c.	Design fee + award costs				
d.	Construction supervision				
e.	Moving Costs				
f.	Relocation Costs				
g.	Initial Training Costs				
h.	Other first costs				
	(1) Subtotal (add above)			w.	
i.	TV energy cost/year				
j.	PV all energy costs			y.	
k.	TV maintenance cost/year				
l.	PV all maintenance costs				
m.	TV service cost/year				
n.	PV service cost				
	(2) Subtotal (j+l+n)			v.	
o.	TV future replacements				
p.	PV all fut. replacements				
q.	TV salvage value				
r.	PV salvage value				
s.	Depreciated resid. worth				
t.	PV residual worth				
	(3) Subtotal (p-r or t)			x.	
	<b>TOTAL LIFE CYCLE COST (1+2+3)</b>			u.	
<b>Indices:</b>					
Net Savings (NS=u):			Savings to Investment Ratio (SIR=v/(w+x):		
For Energy Conservation Projects: ESIR=z/w:			ECSR= y/w:		

**SAMPLE LIFE CYCLE COST ANALYSIS**

Building Name: Federal Office Building			Building No: AH 102		
Project Name: Missouri Federal Building			Project No: F-003-004		
Concept Title:					
Analysis Period: 25 Years			Real Disc. Rate: 4.7%		
Energy Savings (z):			Building Energy Use: 1 010 000 KJ/SM/YR.		
	<b>Cost Elements</b>	<b>Baseline</b>	<b>Alternate</b>		<b>Difference</b>
a.	Construction Cost	\$2,979,961	\$2,997,613		
b.	Contingencies				
c.	Design fee + award costs	N.A.	N.A.		
d.	Construction supervision	N.A.	N.A.		
e.	Moving Costs	N.A.	N.A.		
f.	Relocation Costs	N.A.	N.A.		
g.	Initial Training Costs	N.A.	N.A.		
h.	Other first costs	\$309,773	\$311,607		
	(1) Subtotal (add above)	\$3,289,734	\$3,309,220	w.	-\$19,486
i.	TV energy cost/year				
j.	PV all energy costs	\$3,215,089	\$3,108,595	y.	\$106,494
k.	TV maintenance cost/year	\$26,000	\$26,000		
l.	PV all maintenance costs	\$329,101	\$329,101		
m.	TV service cost/year				
n.	PV service cost				
	(2) Subtotal (j+l+n)	\$3,544,190	\$3,437,696	v.	\$106,494
o.	TV future replacements				
p.	PV all fut. replacements	\$111,415	\$111,415		
q.	TV salvage value	\$0	\$0		
r.	PV salvage value	\$0	\$0		
s.	Depreciated resid. worth				
t.	PV residual worth	\$0	\$0		
	(3) Subtotal (p-r or t)	\$111,415	\$111,415	x.	\$0
	<b>TOTAL LIFE CYCLE COST (1+2+3)</b>	\$6,945,338	\$6,858,331	u.	\$87,007
<b>Indices:</b>					
Net Savings (NS=u):\$87,007			Savings to Investment Ratio (SIR=v/(w+x): 5.47		
For Energy Conservation Projects: ESIR=z/w			ECSR=y/w		



# **CHAPTER 2 SITE PLANNING AND LANDSCAPE DESIGN**

## **General Approach**

Harmony among elements on site and between the site and its surroundings is the hallmark of a well planned GSA project. The quality of the site design should be a direct extension of the building design and should make a positive contribution to the surrounding urban, suburban or rural landscape.

Three characteristics usually distinguish GSA buildings from buildings built for the private sector: longer life span, changing occupancies and the use of a life cycle cost approach to determine overall project cost. GSA generally owns and operates its buildings much longer than private sector owners. Accordingly, a higher level of durability is required for all systems, including site structures and underground utilities.

***FACILITIES STANDARDS FOR THE PUBLIC BUILDINGS SERVICE***

---

During the life span of a typical Federal building, many minor and major alterations are necessary, as the missions of Government agencies and departments change. The site should be designed to accommodate periodic renovation activity by providing flexibility of access and the potential for staging areas.

Private developers base their costs on the amortization of the original building shell and standard tenant fit-up. All later requirements are done as an expense to the tenant. GSA, although still charging expense to the tenant, uses a life cycle cost approach to minimize the total cost to the Federal Government, which is both landlord and tenant. The result is that GSA capitalizes a higher proportion of the initial cost than a private developer.

## Codes and Standards

See Chapter 1: *General Requirements, Codes and Standards* for a complete discussion of model codes and standards adopted by GSA. This section highlights regulations and standards that apply to site design.

### Zoning Regulations

As stated in Chapter 1: *General Requirements, Codes and Standards, Building Codes, Zoning Ordinances*, GSA follows a "good neighbor" policy of complying with local zoning ordinances and subdivision regulations. Unless there is overriding reason to the contrary, GSA respects local restrictions on setbacks, height, massing, signage and site design requirements. Landscape provisions in local ordinances should be viewed as a minimum requirement. Where the specific project program is in direct conflict with local regulations, GSA will seek a variance from the jurisdiction.

Local regulations must be followed without exception in the design of systems that have a direct impact on off-site terrain or utility systems, such as storm water run-off, erosion control, sanitary sewers and storm drains and water, gas, electrical power and communications, emergency vehicle access, and roads and bridges.

**Parking.** With respect to the number of parking spaces, the requirements stated in the building program take precedence over zoning regulations in all cases.

***FACILITIES STANDARDS FOR THE PUBLIC BUILDINGS SERVICE***

---

Standards for Site Planning and Landscape Design

**Local Standards.** Local design standards for site planning and landscape design should be used to the greatest extent possible. If the borough or town has no standards, use the standards of other jurisdictions in the following order: county or State.

Use American Association of Nurserymen: ANSI Z60.1 as a design guide in addition to local standards.

**Historic Preservation.** If the project involves renovation or rehabilitation of a historic building, new construction in a historic landscape or historic district, or construction that may affect archeological sites or other historic properties, GSA may establish conditions which include standards and criteria that must be followed during site planning and landscape design.

## Site Analysis

Successful site planning and design depends on a thorough review and understanding of existing conditions on and around the site. An on-site investigation must be carried out prior to any design effort. The requirements for the resultant design are listed in the GSA document *Submission Requirements for Design and Construction (PBS-PQ280)*.

**Survey.** A complete site survey is required for all new construction projects and for alterations that involve work outside the existing building lines. Survey requirements are listed in the GSA document *Submission Requirements for Design and Construction (PBS-PQ280)*.

**Geotechnical Investigation.** Requirements for all geotechnical investigations are listed in the GSA document *Submission Requirements for Design and Construction (PBS-PQ280)*.

**Archeological Testing.** In some cases, GSA requires specialized testing by a contractor to determine whether archeological sites are present, and if so, to determine their extent, character and significance. If such testing is required, it should be coordinated with geotechnical testing to ensure that such testing does not inadvertently damage archeological resources. The GSA Project Manager will inform the architects and engineers when such archeological investigations may affect the project.

## **General Site Planning Criteria**

**Existing Site Features and Existing Vegetation.** Existing natural features on the site should generally be preserved and be used as a starting point for the overall site design. Efforts should be made to preserve healthy trees, particularly if they are mature specimens.

**Mitigating Undesirable Conditions.** Hazards and nuisances from off-site or on-site sources should be carefully considered when developing the site plan. The negative effects of air, noise, smoke or dust pollution should be minimized by taking advantage of such factors as natural terrain, existing vegetation and building orientation. Berms and planted buffer strips should also be considered.

**Energy Conservation.** The use of site design to aid energy conservation is encouraged. Solar orientation can be used to increase heat gain in the winter and reduce heat gain during the summer. Coniferous trees can be used as windbreaks during the winter and can also provide shade during the warm seasons. Deciduous trees can be placed to shade low-rise buildings and paved surfaces during the summer, while allowing heat gain during the winter. Maximizing the amount of green space will also help mitigate heat build-up during the summer.

**Future Expansion.** The potential for future expansion is an important element of the site design concept. Areas for building expansion should be identified in the architectural and site concepts for all GSA buildings and may take the form of new buildings on site or of horizontal building additions. In either case, the site design should accommodate future building expansion with minimal disruption and cost. The location of permanent parking lots, cooling towers, electrical generators, transformers and substations, as well as underground utility lines, vaults and fuel oil storage tanks, should be determined with expansion plans in mind. In areas designated for future building expansion, inexpensive pavements with a shorter life span should be considered.

## **Grading**

**Slopes.** The slopes of planted areas should permit easy maintenance. Turf areas should have a slope of no more than 1:3 and no less than 1:100. A 1:500 minimum slope is desirable. Areas with slopes steeper than 1:3 must be planted with ground cover or constructed with materials specifically designed to control erosion. Slopes steeper than 1:2 are not acceptable. Terracing may be an appropriate solution for sites with large grade differentials, as long as access for lawn mowers and other maintenance equipment is provided. Figure 2-1 shows a schematic section for a possible site with steep slopes.

Normally, the grade at the property line should match the grade of the adjoining property. Should retaining walls be used at the property line, they must not adversely affect the use or views of the neighboring property.

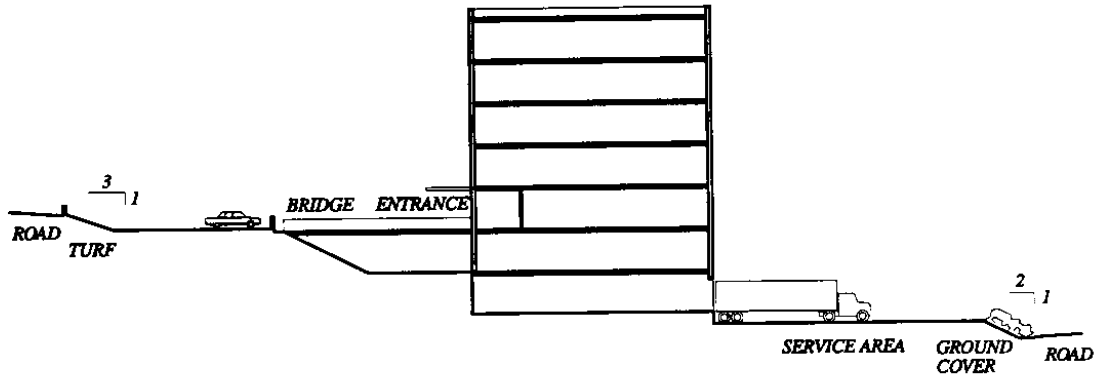

Figure 2-1  
Schematic Section Through Steep Site



The minimum slope for grassy swales and drainage ways is 1:100 to prevent standing water and muddy conditions.

Slopes for walkways should not exceed 1:20, unless unavoidable. Slopes greater than 1:20 may make the construction of special ramps for the disabled necessary. The maximum cross-slope is 1:50. Preferably, walkways should not have steps. Where steps are necessary, cheek walls enclosing the risers and treads should be used to make a smooth transition to planted areas on the sides of the steps.

Parking areas or large entrance plazas should have slopes of 1:100 minimum and 1:20 maximum. Drives within parking lots should not be crowned. In areas with snowfall, provisions should be made for piling snow removed from roads and parking areas.

Drains should be provided at the entrance to ramps into parking structures to minimize the amount of rainwater run-off into the structure.

**Grading Adjacent to Buildings.** Paved and planted areas adjacent to buildings should have a 1:100 minimum slope to provide positive drainage of surface water away from the structure to a curb line, inlet or drainage way.

**Grading Around Existing Trees.** Where trees are to be preserved, the existing grade within the circle of the tree drip line must not be disturbed by regrading or paving.

**Cut and Fill.** From a cost standpoint, it is desirable to minimize grading overall and to balance cut and fill, particularly in campus settings.

**Grading and Flood Plains.** If GSA decides to locate a building within a 100-year flood plain, situate the building out of the 100-year flood way and provide flood proofing by elevating the building rather than filling in land. A minimum elevation of 1 500 mm above the 100-year flood plain elevation should be provided for the first occupied floor. Mechanical and electrical equipment rooms must not be located below the level of the 100-year flood plain. Where possible, parking areas and drives should also be located above the 100-year flood plain elevation a minimum of 300 mm. No grading should be performed within the boundaries of any wetland.

Erosion and Sediment Control

**Storm Water Detention.** Local code requirements for storm water detention must be followed. Storm water detention reduces the peak rate of water discharge into sewers, streams and ditches downstream of the site. The lower peak flow causes less flooding and erosion downstream. Detention facilities must mitigate the effect of increased run-off from new development and improve the water quality of the run-off. Detention facilities are especially helpful in areas where existing drainage systems are already at or near capacity. Detention of storm water on GSA building rooftops is not permitted.

## Site Utilities

### Utilities Services

The A/E is expected to contact the local utility companies to determine their interest in providing service to the GSA, proposed rate structures, rebates, system capacity, etc. This information will be compiled on the Site Analysis Data Sheets (see GSA document *Submission Requirements for Design and Construction [PBS-PQ280]*). GSA will negotiate contracts with the utility companies that will fix rates and connection charges.

**Location of Above-ground Utility Elements.** It is the site designer's responsibility to ensure that all utility elements, such as electrical transformers, emergency generators, backflow preventers and meters, are located with access convenient to the utility companies and where they can be integrated with the building and landscape design without creating a negative visual image.

### Water Distribution

**Local Water Authority.** Regulations of local water authorities must be followed. The service connection between building and public water line should be coordinated with the local water authority. Where municipal graywater is available, service connections should be coordinated with the local water authority.

**Dual Service.** For large buildings or campuses, a loop system fed from more than one source should be considered. Some occupancies require dual service for the fire protection systems under the provisions of the national code used.

**Locating Water Lines.** Water lines should be located behind curb lines, in unpaved areas if possible, or under sidewalks if not. They should not be located under foundations, streets, drives, or other areas where access is severely limited.

**Sizes of Pipes.** Domestic water lines should be sized for peak flows based on fixture unit calculations and fire protection.

**Post Indicator Valves.** In campus settings a post indicator valve is required on the fire protection service for each building.

**Fire Hydrants.** Fire hydrants must be spaced so that all points on the building façades are within 90 m of a hydrant. Hydrants should be located with 1 500 mm of roadways accessible to fire trucks. At least one fire hydrant should be placed within 30 m of the siamese connection at the building. Thread sizes for hose connections must be coordinated with the local fire department.

**Detector Check Valves.** Fire protection lines should be provided with detector check valves located at the point where the line enters the building.

#### Sanitary Sewer System

**Local Sewer Authority.** The regulations of the local sewer authority should be followed.

**Discharge in Remote Rural Areas.** In areas where no public sewers exist, septic tanks and leach fields should be used for sewage discharge. Cesspools are not permitted. Septic systems should have additional land area (50 percent of that required for the system design) for future expansion of the discharge system.

**Locating Sewer Pipes.** All sewer lines should be located below unpaved areas if at all possible. They must be separated from potable water lines by a lateral distance of at least 3 000 mm. This distance can be reduced to 1 800 mm where the bottom of the water pipe is located 300 mm or more above the top of the sewer pipe. Where sanitary lines cross above water lines, the sewer must be encased in concrete or placed in a suitable pressure pipe for a distance of 3 000 mm on either side of the crossing.

**Sizes of Pipes.** Sewer lines should be sized so peak flow does not exceed approximately 75 percent of pipe capacity, with a minimum velocity of 0.75 m/s. Minimum pipe size for service connections is 150 mm, minimum size for mains is 200 mm.

**Manholes.** Manholes should be provided at all intersections and at locations where changes in pipe size or gradient occur. The maximum distance between manholes should be 90 m, except for lines 450 mm and larger where a spacing of 120 m is acceptable.

Where the line enters the manhole 450 mm or more above the effluent line invert elevation, drop manholes should be used.

Pipe runs between manholes should be straight lines. Curved lines should not be used. A flexible, gasketed joint should connect pipe runs and manholes.

**Service Line Connections.** Service lines less than 30 m long can be tied into mains with a wye connection. On lines longer than 30 m, manholes should be provided.

**Cleanouts.** Cleanouts should be provided on all service lines, approximately 1 500 mm away from the building, and at all line bends where manholes are not used.

#### Storm Drainage System

The storm drainage system conveys storm water collected on site to an acceptable point of discharge. It is GSA policy to separate storm drains from sanitary sewers within the property limits, even in cities where separate public systems are not yet available. A storm drainage system may consist of an open system of ditches, channels and culverts or of a piped system with inlets and manholes.

In most cases building roof drainage will be collected by the plumbing system and discharged into the storm drains; exceptions are small buildings in rural areas where gutters and downspouts may discharge directly onto the adjacent ground surface.

The storm drainage system should be designed for a 10-year storm frequency, unless local criteria are more stringent.

**Gravity Drainage.** Storm drainage systems should always use gravity flow. Piped systems are preferred. In large campus settings, open ditches or paved channels should be avoided as much as possible.

**Location of Storm Drainage Pipes.** Storm drainage pipes should be located in unpaved areas wherever possible. It is desirable to offset inlets from main trunk lines to prevent clogging.

## Site Circulation Design

Site circulation design for GSA projects will vary greatly depending on the context, which can range from tight urban sites to suburban campuses or isolated rural settings. Yet the basic criteria remain the same in all situations: the site design should segregate, at a minimum, pedestrian access, vehicular access (including parking) and service vehicle access.

### Urban Site with Underground Parking

**Service Traffic.** Service dock access may be from an alley, from a below-grade ramp or from a site circulation drive. Sufficient maneuvering space must be provided, and the service drive should be screened as much as possible. It should always be separate from the access to the parking garage. Where possible, a one-way design for service traffic is preferable to avoid the need for large truck turning areas. See Chapter 3: *Architectural and Interior Design, Space Planning, Building Support Spaces, Loading Berths* for criteria on ramps and service areas.

**Public Transportation.** GSA encourages the use of public transportation among employees and visitors. The potential need for a bus stop should be considered early in the design of a GSA building in an urban setting and should be discussed with planners of the mass transit system.

**Drop-Off.** A vehicular drop-off area should be located on the street nearest the main entrance and, site conditions permitting, also near the entrance to the child care center, if the project includes one. See *GSA Child Care Center Design Guide (PBS-PQ140)*, Chapter 6: *Site Design*.

### Vehicular Drives, Parking Lots and Service Areas

**Entrance Drives.** Follow local codes for entrance driveways within the right-of-way limits of city, county or State maintained roads.

**Surface Parking Lots.** Standard size parking stalls must be 3 000 mm wide and 5 400 mm long, with two-way aisles of 7 200 mm. Where possible, 90 degree parking should be used.

Internal islands for landscape planting should occupy no less than 10 percent of the total parking lot area. Curbs should be provided around the parking lot perimeter and around landscape islands.

The maximum combined gradient for parking lots should not exceed 1:20.

#### Walkways

Walkways can be more than a means of getting people from one place to another. They should be an integral part of the landscape design and provide a pleasant, reasonably direct route to building entrances. They can widen into sitting areas or small plazas or be linked into a system of exercise trails. Access for the disabled should be integrated into normal pedestrian routes so that separate paths and ramps are not specifically required.

Walkways that parallel drives should be separated by a 1 500 mm wide planting strip, if possible. This increases safety, protects pedestrians from being splashed by cars in rainy weather and provides a space for stacking snow removed from drives and walkways.

Manholes, storm drain inlets, utility gratings, clean-outs and valves should not be located in walkways because they constitute a tripping hazard. If a grating must be placed in a walkway, the opening between bars should be minimized for pedestrian safety.

**Walkway Width.** Walkways should be as wide as necessary to accommodate pedestrian traffic but no less than 1 500 mm wide. This width allows two people to walk side by side or to pass one another. Where walkways are located adjacent to parking areas, the nearest edge of the walkway should be at least 750 mm from the curb to accommodate car overhangs.



## Pavements and Curbs

**Materials.** Usually the best wearing paving materials are those that are used extensively in the local area. Pavements and curbs should be designed for ease of long term maintenance, not just for first cost. Pavement color and texture should be chosen to minimize glare into the buildings. This applies especially to pavements on the south side of buildings.

**Texture and Pattern.** Pavement texture and pattern should be used to indicate changes in function, such as pedestrian crossings in roadways and building entrance areas. Where masonry pavers are used, epoxy mortar should be considered to control water penetration into the vertical joints. Textured pavements should not be so rough as to make travel difficult for bicycles or wheelchairs but rough enough so they do not become slippery when wet.

**Curbs.** Do not use precast concrete curbs.

**Drives.** Should meet local codes requirements for street. Decorative bollards may be used where necessary to prevent vehicular incursion into pedestrian space.

**Fire Lanes.** Grass pavers or open concrete grids are encouraged for fire lanes that do not carry normal vehicular traffic.

**Service Areas.** Areas for truck maneuvering should have concrete pavements.

**Pavement Markings.** Follow local street code.

**Signage for Roads and Parking Lots.** The minimum number of signs necessary to convey the information should be used.

## **Landscape Design**

The landscape design plays an important role in unifying the built elements of the site. Its primary function should be to create a pleasant, dynamic experience for the staff and visitors who use the site every day, walking on their way to and from work, eating, or just sitting in the sun at lunch time and during breaks. But the landscape is also important as seen from inside the building, both from the ground floor and upper levels. In addition, the landscape functions as a setting for the building or campus as seen from off-site by passing pedestrians and motorists. All of these points of view should be taken into account in the overall landscape design.

For projects located in a district designated for special landscaping by the local Government, local design guidelines should be followed.

### **Maintenance Considerations**

Before initiating the landscape design, the landscape architect should investigate how the landscaping will be maintained. If this information is not available, assume that only limited maintenance capabilities will be available.

### **General Design Principles**

Given limited maintenance budgets, GSA conceptually divides a typical site into two categories. Category I areas have high visibility and consist of highly developed designs. Category II areas have lower visibility and are of simpler design.

Category I will typically include the site entrance, main building entrance, courts, plazas, open spaces between sidewalks and the building, eating and sitting areas, roof gardens and parking lots located in front of the building. A fairly intensive level of design is expected in these areas, along with planting schemes which are planned in a more architectural, stylized treatment. The design of landscaped areas adjacent to the main building entrance should be especially sensitive to the architectural features of the building. Maintenance requirements are assumed to be higher than those for Category II areas. Special features, such as fountains or ponds and planters, may be used as well as landscape lighting.

Category II includes areas around parking lots located to the side or rear of the building, maintenance areas, loading docks and outlying areas in general. Here planting should be simpler, require far less maintenance and consist largely of indigenous trees, grasses and ground covers.

The proportions of Category I and II areas will depend on the level of total maintenance capability. As the landscape design is developed, Category I and II areas should be identified on the drawings to clarify the design concept. A preliminary description of the necessary maintenance program should also accompany the Final Concept Submittal. See the GSA document *Submission Requirements for Design and Construction (PBS-PQ280)*.

#### Landscape Elements

**Courts and Plazas.** The most important considerations in designing exterior courts and plazas are human scale and comfort. Avoid large, open, windswept plazas and consider the effect of shadows cast both by the GSA building and adjacent buildings. A well designed exterior court or plaza offers both sun and shade, protection from severe winds, pleasant views and a variety of comfortable seating areas, which can accommodate various size groups in both private and public settings. Where feasible, outdoor eating areas should be considered, either as an extension of the cafeteria or as a stand-alone function. They should be separated from public areas by planters or walls.

**Roof Gardens.** Roof gardens are very difficult to maintain and should therefore be discouraged.

**Fountains, Reflecting Pools and Ponds.** Water may be used as a visual and possibly as an acoustic element. However, water features should not become a maintenance burden. Water consumption should be kept low, especially in very dry climates with high evaporation rates. In colder climates provisions must be made for easy shut-off during the winter season. Fountains and reflecting pools with pumping systems are restricted to Category I areas of the site. Water features should not be placed over occupied space since leakage problems frequently occur.

**Planters.** Generally large planter cut-outs in the pavement will be more successful than small ones because plants are less subject to damage from frost, drying out or lack of air movement in the root zone. This is especially true in urban situations.

Raised planters are useful for defining outdoor space and adding levels to otherwise flat terrain. They are also considered high maintenance, Category I elements.

**Sculpture.** Sculpture may be provided as part of the Art in Architecture Program. It is not addressed by the site designer except as a coordination effort since the sculptor is selected under a separate contract.

**Rocks and Boulders.** Lightweight and synthetic rocks or boulder should not be used as landscape elements. Experience has shown that they are subject to vandalism.

## Plant Materials

Planting should be used to enhance the aesthetic appeal of the site and emphasize the characteristics of the terrain. Plant selection, including turf, should be based on the plant's adaptability to the region. Other factors to consider include growth rate, maintenance requirements and water consumption of the plants.

**Existing Vegetation.** Existing stands of mature trees should be used as a starting point, and a planting plan should be built around them. Existing vegetation should always be considered first.

**Plants for Microclimate Control.** Deciduous trees located near the south or west exposure of a building can reduce summer insolation and save cooling energy by providing shade, while allowing solar penetration during the winter. Dense plantings of tall evergreens can act as windbreaks and reduce winter heating requirements in cold climates.

### Species Selection

**Hardiness and Availability.** Plants must be hardy in the climate where they are to be planted. Plants should be available at local nurseries and familiar to local horticultural agents. Plants that have to be shipped from outside the region should not be used for two reasons: (1) they are typically raised in soils and climate conditions different from those on the site, and (2) it is difficult to replace them at a later date.

**Demanding Plants.** Plants requiring meticulous soil preparation, fertilization and spraying should be avoided.

**Growth Habits.** Plants should be chosen with their mature size and growth habit in mind to avoid overplanting and conflict with other plants, structures or underground utility lines.

### Placement

Landscape design should be closely coordinated with the architectural characteristics of the building. There is no "preferred" landscape style; while formal arrangements of trees and shrubs may be appropriate for certain locations, an informal or asymmetrical placement makes uneven growth and the loss of individual plants less noticeable. Building window and door placement and the effect of planted areas as seen from the building interior should also be considered.

Trees should not be planted where they could make it easier for potential intruders to climb a wall or reach an upper story window. Avoid placing large shrubs in parking lot islands or adjacent to walkways where they could become hiding places for assailants.

Turf areas should not be used as a filler, but should be considered a major element of landscape design. Slower growing grasses should be considered for extensive turf areas. Turf should not be used for small islands in parking lots because it is too difficult to maintain. Trees, shrubs in low hedge rows and low-maintenance ground covers are more suitable in these locations.

### Planting Practices

**Tagging.** Tagging of plant materials at the nursery should be employed only selectively for specimen plants, not for the entire project. Instead, specifications should be tight enough to provide criteria for a rigorous inspection at the project site and rejection of plants if necessary.

**Staking.** Local conventions for staking, wrapping and guying trees should be followed. Local extension horticulturists can provide good advice.

**Warranties.** Warranties for the replacement of plant materials must be specified to extend for 1 year after date of building acceptance by GSA.

**Mulch.** Mulch depth should be 75 mm to 100 mm to inhibit weed growth, limit evaporation and modify the extremes of soil temperature. Bark products, pine needles or other organic materials are preferred over inert mulches, such as gravel which reflects heat and can burn plants.

## **Irrigation for Landscaping**

### System Design

**General Criteria.** The irrigation system should provide water to plants only when needed. Infrequent, deep watering is more desirable than frequent, shallow watering, as it encourages better root growth, resulting in healthier, more drought-tolerant plants.

Drip irrigation should be considered; it may be feasible for some landscape designs.

Reliable performance should be a prime goal in the design of irrigation systems. Materials should be durable and relatively maintenance free. Irrigation systems will be most successful in the long run if local design practices are followed and locally available materials are used.

Allow for expansion of the irrigation system, both in area and in flow rate, so the system can be adjusted as plants mature.

**Metering.** Irrigation water should be metered separately from domestic water to avoid expensive user sewage fees.

**Zoning.** Irrigation systems should be zoned so different areas can be watered at different times. Avoid mixing different head or nozzle types (such as a spray head and a bubbler) on the same station. Different types of vegetation, such as turf and shrub areas, should also not be placed on the same station.



**Application Rates.** The system should be designed to minimize surface run-off. In heavy clay soils, a low application rate may be required. Overspray onto paved surfaces should be avoided because it wastes water and poses a potential hazard for pedestrian and vehicular traffic. In cooler climates overspray may freeze, creating a potential liability problem.

**Fittings.** Components of the irrigation system should be of rugged design and easy to operate and maintain. Rotary heads should have adjustable arcs and radii. Swing-joint assemblies or flexible polyethylene connections should be installed between head and lateral piping.

Small spray or bubbler heads should be connected to lateral piping by flexible PVC risers, flexible polyethylene piping or semi-rigid polyethylene fittings.

Fixed risers should only be used in areas that are clearly separated from pedestrian circulation.

**Controls.** Irrigation controls should be easily understood by maintenance personnel. Provide automatic controls to allow for scheduling of watering times for late night and early morning to reduce water losses due to evaporation.

Rain sensors or soil moisture sensors are essential to prevent unnecessary watering. Freeze sensors should be provided for systems in cold climates.

**Maintenance Considerations.** All major components should be installed in protected, accessible locations. Manual and remote control valves must be installed in boxes not buried without protection. Controllers and remote sensing stations should be placed in vandal-proof enclosures. Above-ground components, such as backflow preventers, should be placed in unobtrusive locations.

Quick coupling valves should be of two-piece body design and installed throughout the system to allow for hosing down areas and to permit easy access to a source of water. Locate drain valves to permit periodic draining of the system.

## **Landscape Lighting**

Landscape lighting should be used to enhance safety and security on the site, to provide adequate lighting for night-time activities and to highlight special site features. See Chapter 6: *Electrical Engineering, Lighting, Exterior Lighting*.

The primary purpose of any particular application of landscape lighting will help determine the requirements for light coverage and intensity. Generally, unobtrusive lighting schemes are preferred. Spillage from parking lot lighting or from lighted windows should be considered, as it may have the effect of washing out the landscape lighting.

**Color.** It is desirable to maintain a single, or at least similar, light color throughout the project site.

**Fixtures.** Site lighting fixtures should complement other site elements. For example, lighted bollards should match unlighted bollards in shape, color and style. Recessed fixtures are desirable in retaining walls and cheek walls at steps.

Fixtures should be placed so users of the space do not look directly at the light source; this impedes night vision. To avoid plant damage and fire hazard, high intensity or heat generating fixtures should not be located immediately adjacent to plant material.

Fixtures should be resistant to vandalism and replaceable from local sources.

**Controls.** Landscape lighting should be switched by clock-activated or photocell-activated controllers.

## Site Furniture

Useful outdoor spaces require furniture just as much as do rooms in a building. Seating, tables, bollards, bicycle racks, trash receptacles and tree grates should be part of the initial site design not afterthoughts.

**Seating.** In areas with temperate seasons, outdoor seating can add a great deal to the relaxation of building employees and pedestrians. Seating should be provided to accommodate as many users as possible. This can include benches, outdoor eating areas, low walls, steps in the landscape or the rim of a fountain.

Some outdoor seating should be located in areas protected from wind, with a choice between sunny and shaded locations. Where there is no natural shade, consider umbrellas or trellises.

Seating (and tables) accessible from public areas should be fixed. Movable seating should only be used in interior courtyards where theft is not a concern.

**Trash Containers.** Locate trash containers on the path people will take to leave a seating area to encourage their use. Where feasible, consider separate containers for recyclable items, such as metals and glass.

**Materials.** Materials for outdoor furniture must be very durable. Metals that require frequent repainting should be avoided.

## **Site Signage**

One goal of a well designed site should be to use as few signs as possible. Signs should make the site clear to the first-time user by identifying multiple site entrances, parking and the main building entrance.

Generally, graphics and style of site signage should be in keeping with the signage used inside the building. Signs integrated with architectural elements can also be very effective.

See Chapter 3: *Architectural and Interior Design, Guidelines for Building Elements, Artwork and Graphics*, and *Exterior Closure, Cornerstone and Commemorative Plaques* for applicable standards.

**Construction Signs.** All GSA new construction and prospectus level repair and alteration projects must display an official construction sign on the site, in a prominent location. Construction signs must conform with the following specifications.

*All Construction Signs.* The size of the sign is be 3 600 mm by 1 800 mm. It should be constructed of a durable, weather resistant material, properly and securely framed and mounted. Standard GSA color (dark blue) with white lettering should be used. Signs should be mounted at least 1 200 mm above the ground, display the official GSA seal (which should be no less than 400 mm in diameter), and provide the following information:

- U.S. General Services Administration.
- (President's name), President of the United States.
- (Administrator's name), Administrator of General Services.
- (Regional Administrator's name), Region X Administrator.

The lettering, graphic style, and format should be compatible with the architectural character of the building.

*New Construction Signs.* Signs at new construction sites should include the name of the architect and general contractor and an artist's rendering or photograph of the model of the building under construction.

*Repair and Alteration Projects.* Signs at prospectus level repair and alteration project sites should include the name of the architect and/or engineers for the major systems work (i.e. structural, mechanical, electrical), if appropriate. In addition, the sign should include the name of the general contractor.

Figure 2-2 represents an example of a sign which is acceptable.

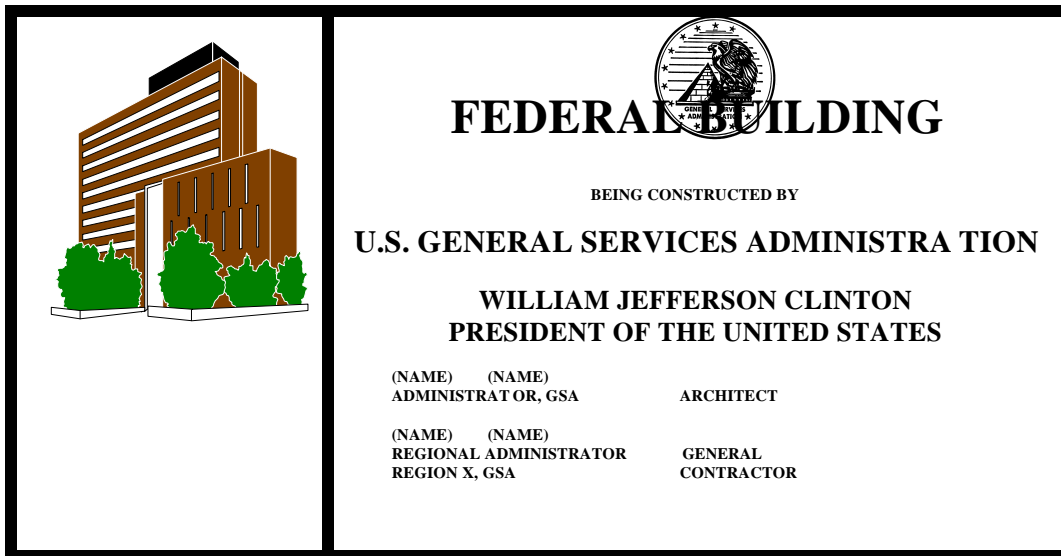

**Figure 2-2  
Construction Sign**



# **CHAPTER 3 ARCHITECTURAL AND INTERIOR DESIGN**

## **General Approach**

It is the vision of GSA to provide the best work environments and the highest quality services to its clients in the Federal Government. As the person responsible for building design, the architect is an extension of GSA. By creating excellent buildings the architect can make GSA's vision a reality.

The design of Federal facilities should demonstrate distinction and quality. The architecture should reflect the dignity, enterprise, vigor, and stability of the United States Government. It should embody the finest contemporary American architectural thought.

The physical world that we create is a significant expression of our civilization. It reflects the imagination and inventiveness of our designers. Therefore, the design of buildings and places should involve more than the mere provision of a solution to requirements. Architecture is a creative act that has the potential to stir the spirit and enrich our lives by its aesthetic qualities.

GSA does not want to mandate, or even encourage, any particular style of architecture. What is most important in the design of Federal buildings can be summarized in a few paragraphs:

First and foremost, Federal architecture should be original. Facilities that mimic the current vogue demonstrate a lack of imagination and quickly become dated. Instead, Federal architecture should express permanence and elegance. The *Guiding Principles for Federal Architecture* quotes Pericles' evocation to the Athenians: "We do not imitate, for we are a model to others." The designer is challenged to create a unique solution responsive to the program, setting and context of the project.

One of the strengths of our country is that it embodies many regional traditions. Federal buildings are built in every state of the union and should always be a part of the regional architecture. The tie to local architecture can be expressed in many ways - through the use of building form, materials, colors, landscape or detailing.

Building interiors should express a quality of permanence and elegance similar to that of the building exterior and provide a graceful introduction for the public as they conduct business with agencies of the Federal Government. The working environment should be perceived as first-class by the public and employees alike. While it need not overawe, it should encourage dignified, polite conduct. It is important that Federal employees be housed in facilities where they can perform to the best of their abilities and be proud of their work place.

Second, Federal buildings must be efficient and functional. During the life span of a typical Federal building, many minor and major alterations are necessary, as the missions of Government agencies change. They will do this gracefully if flexibility has been designed into all building systems from the outset. From the architect's point of view, the building needs to be more than the sum of the program requirements. The questions that need to be asked constantly during the conceptual design stages are: "How easy will it be to change the layout?"; "How easy will it be to add security (or computer rooms, or air conditioning)?"; "Can the building work equally well for one large agency or several small ones?" Many of the specific guidelines of this book arise from the need for flexibility.



Private developers base their costs on the amortization of the original building shell and standard tenant fit-up. All later requirements are done as an expense to the tenant. GSA, although still charging expense to the tenant, uses a life cycle cost approach to minimize the total cost to the Federal Government, which is both landlord and tenant. The result is that GSA capitalizes a higher proportion of the initial cost than a private developer.

Third, it is GSA's goal to build buildings with space for the latest advances in office technology and communication. This should be extended to anticipate the future evolution of technology as well. Making this concept a reality requires comprehensive design for architectural and engineering systems. In the interest of building systems integration, it is mandatory to develop the design work of all disciplines simultaneously with the architectural concept rather than retrofitting engineering systems into a solidified architectural design.

## **Codes and Standards**

Model codes and standards adopted by GSA are discussed in Chapter 1: *General Requirements, Codes and Standards*. This section describes code requirements and standards that apply to architectural design and highlights the few instances where GSA policy differs from the adopted national codes.

### Zoning Regulations

The policy for compliance with local zoning regulations is described in Chapter 1: *General Requirements, Codes and Standards, Building Codes, Zoning Ordinances*. The following text notes exceptions to that policy which GSA is required to make because of Federal regulations.

**Parking.** GSA will provide parking for Government-owned vehicles and cars of visitors and employees, with due regard to local zoning and parking regulations. However, the number of parking spaces provided may not equal the number stipulated in the zoning ordinance in all cases. If there is a discrepancy between the zoning regulations and the project program, the program will govern. Zoning provisions with respect to the size and configuration of parking facilities should be followed.

### Building Codes

As stated in Chapter 1: *General Requirements, Codes and Standards, Building Codes*, facilities should generally comply with the requirements of model building codes except as follows:

**Egress Requirements.** The egress requirements of the NFPA Standard 101 Life Safety Code should be followed in lieu of the exit requirements of model building codes. See Chapter 7: *Fire Protection Engineering, Architectural Requirements, Egress Requirements* for additional egress requirements mandated by GSA policy.

**Energy Conservation Requirements.** Energy conservation requirements are detailed in Chapter 1: *General Requirements, Codes and Standards, Mandatory Design Standards, Energy Conservation Standards*.

**Toilet Fixture Requirements.** The method for calculating the required number of fixtures in office buildings is described in section *Space Planning, Building Support Spaces, Toilet*

*CHAPTER 3. ARCHITECTURAL AND INTERIOR DESIGN*

---

*Spaces* of this chapter. It should be used in lieu of the numbers stated in the national code used.

***FACILITIES STANDARDS FOR THE PUBLIC BUILDINGS SERVICE***

---

Architectural Design Standards

The standards listed here are intended as guidelines for design only. The list is not meant to restrict architects from using additional guides or standards as desired.

National Roofing Contractors Association: Roofing and Waterproofing Manual.

National Concrete Masonry Association: NCMA-TEK.

Precast Concrete Institute: Architectural Precast Concrete.

Association of Architectural Metal Manufacturers: AAMA Standard 101.

National Association of Architectural Metal Manufacturers: NAAMM Standard SW-1.

Sheet Metal and Air Conditioning Contractors' National Association: SMACNA Architectural Sheet Metal Manual.

Electronic Industries Association/Telecommunications Industry Association (EIA/TIA) 569: Commercial Building Standard for Telecommunication Pathways and Spaces.

## Site and Context

### Building Form, Proportion, Scale and Context

Building massing creates solids and voids; their skillful interplay is the hallmark of excellent design. Buildings are perceived either as "object buildings" surrounded by space or as "wall buildings" enclosing a space as shown in Figure 3-1. In urban settings either one can be appropriate, but it is interesting to note that the great cities of the world treasure great spaces more than great objects.

**Wall Buildings.** Wall buildings continue the scale and patterns of their neighbors through complementing use of arcades, setbacks, cornices and fenestration. They become the stage set for the urban scene passing in front of them. If the neighboring buildings contain retail stores, the GSA building should probably also have storefronts at the ground level. If it is

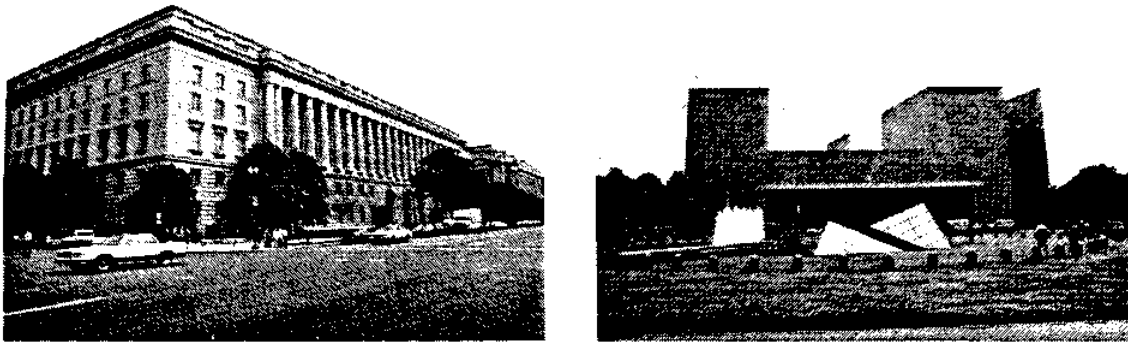

out of step with its context, a Federal building will detract from, rather than enhance, the existing cityscape.

*Wall Building*

*Object Building*

Figure 3-1  
**Wall and Object Buildings in an Existing Urban Pattern**

**Object Buildings.** An object building by definition is surrounded by open space that may provide an opportunity to shape a small park or public square. Note that the typical "plaza" in front of an urban highrise does not qualify. It is often a forbidding, windswept place that pedestrians hurry to cross as fast as possible. A good urban, pedestrian space contains landscaping, benches and fountains. It is a place to linger and enjoy.

**Highrise Buildings.** The massing of highrise buildings needs to be studied in three distinct components: top, body and base. The top of the building should have a unique and meaningful form to be an interesting part of the local skyline. The body of the building, supported by the base and crowned at the top, should be sized to relate to neighboring buildings, with consideration given to the planned future development of the immediate area. The base of the building establishes a connection between building and pedestrians. Since a pedestrian's view of a building extends about 7 600 mm to 9 100 mm above the sidewalk level, the building elements at this level should be scaled and refined

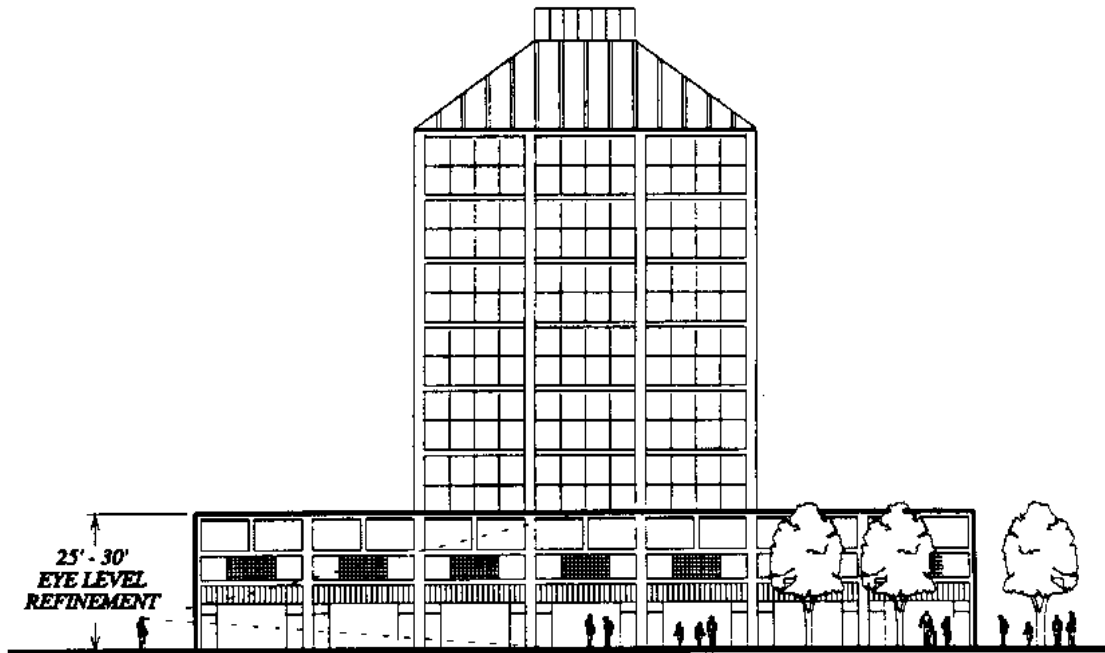

appropriately, as illustrated in Figure 3-2.

Figure 3-2  
**High Rise Building**

**Urban or Rural Context.** In cities, a GSA building should enliven the urban scene. It should enrich the experience of those who use it and pedestrians who pass by it or through it. In rural settings, the building should become part of the landscape and fit into the existing topography and vegetation.

**Environmental Sensitivity.** The natural setting of the site, its contours and vegetation should be viewed as assets to be preserved and woven into the design as much as possible. In the larger sense, the design should reflect an environmental awareness in the choice of building materials that can be manufactured without a significant adverse effect on the natural environment.

**Orientation.** Where a choice exists, it is desirable to orient the building to reduce energy consumption. Factors that should be evaluated are solar gain, prevailing winds and daylighting potential.

**Exterior Circulation.** Four categories of circulation usually have to be accommodated on the building site: vehicular traffic to a drop-off area, vehicular traffic to and from parking, pedestrian access to the building and vehicular service access. Car and truck traffic needs to be integrated into the off-site street patterns, as described in Chapter 2: *Site Planning and Landscape Design, Site Circulation Design*.

Service traffic must always be segregated from car traffic and pedestrian access. This traffic should be taken to a service area in the building which is separate from and not in view of the front entrance. Pedestrian traffic arriving from the street, from parking areas or from the drop-off should all be collected in the main building lobby. Buildings may have a separate employee entrance close to parking areas, but this should also connect to the main lobby. Pedestrian access should not be endangered by car traffic. This is particularly important in suburban locations.

**Building Character and Exterior Materials.** The exterior walls of GSA buildings should be made from a palette of materials to achieve a simple and elegant look. Various textures or colors of the same material may be used to articulate forms and to create contrasts. Durability and maintainability are of prime concern.

In general, the materials acceptable for building skins can be classified into four groups: stone; brick or tile; precast concrete panels; and metal and glass curtain walls.

In most instances, materials which need to be periodically painted are not acceptable for the building exterior.

**Facade Articulation.** Facade articulations, as shown in Figure 3-3, increase the opportunity for corner offices and special spaces in open office layouts, like conference rooms and lounges. The articulation should be carefully designed to avoid adding excessive construction costs, but it is worth considering, particularly in large buildings.





*Ziggurat Façade*

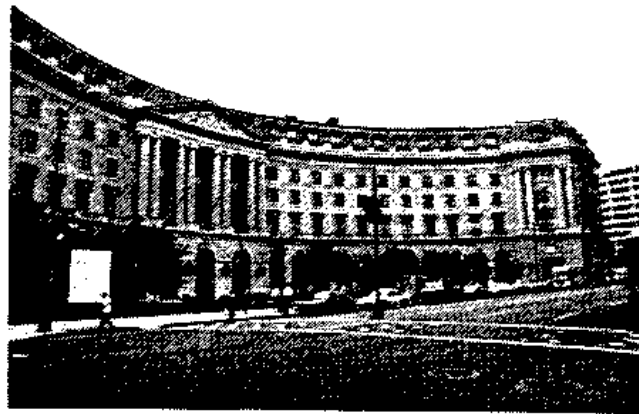

*Concave Façade*

Figure 3-3  
**Facade Articulation Examples**

## **Building Planning**

**Basic Configurations and Core Placement.** The single most important factor in determining building configuration and core placement is the size of the footprint. Experience has shown that the optimum depth of the occupiable space (the space between core and window wall) in an office building is approximately 12 000 mm.

**Core Placement and Circulation Patterns.** Above all, the building circulation must be simple, comprehensible to visitors and convenient for everyday staff use. On the typical floor of an office building, core elements usually consist of elevators and elevator lobbies, stairs, toilets, janitor closets, and mechanical and electrical equipment spaces and shafts. These elements may be located on the floor in various arrangements: centralized, diffused, at the exterior perimeter or in modular fashion between building elements. Each arrangement has different implications for size and configuration of the building footprint. See Figure 3-4.

The centralized core provides the shortest corridor travel distances, which increases functional efficiency and occupiable space. The main building circulation is a corridor loop around the core, either directly or through the center of the adjacent space for larger floor plates. This planning concept allows less contiguous floor space for the planning of large open areas, but it is a practical solution for floor plates up to about 1 400 m<sup>2</sup>.

Modular cores are particularly appropriate for buildings with known future expansion. It tends to lengthen the corridor travel distance and may increase cost because of multiple cores. Circulation patterns for buildings with modular cores can be racetracks, H-shaped or X-shaped. In each case, all cores should be connected by the primary circulation.

Diffused cores - double or triple - are often required in long or large rectangular buildings. They allow larger footprints than a central core building, but they are less efficient because the main circulation must connect all cores on every level. They tend to have the same increased cost and duplication of the modular core.

The exterior core arrangement places core elements at the floor perimeter. It maximizes the contiguous usable space and permits the design of large rooms in any configuration. It also allows the linking of blocks of floor space in a modular fashion and provides a logical place for future expansion.

**Placement of Core Elements and Distances.** In buildings with large floor plates, not all core elements need to be placed at each core location. How often each element needs to be repeated is governed by occupant needs and the following maximum radii and distances:

- *Elevators* should always be grouped in banks of at least two for efficiency. Travel distances from a given office or work station to an elevator can be up to 61 000 mm.
- *Stair* placement and travel distances to stairs are governed by code. See also Chapter 7: *Fire Protection Engineering, Architectural Requirements, Egress Requirements* for specific egress requirements.
- *Toilets* should also be placed within 61 000 mm of every office or work station.
- *Electrical Closets* must be stacked vertically and should be located so that they are no more than 45 000 mm from any occupied space. Shallow, secondary closets off permanent corridors may be used for receptacle panelboards where the distance between the riser and the farthest work station exceeds 4 500 mm and a separate riser is not warranted. See section *Space Planning, Building Support Spaces, Mechanical and Electrical Rooms* of this chapter for minimum size requirements.
- *Communications Closets* must be stacked vertically and should be placed so that wiring runs do not exceed 76 000 mm. The design should comply with EIA/TIA 569: Commercial Building Standard for Telecommunication Pathways and Spaces. See section *Space Planning, Building Support Spaces, Mechanical and Electrical Rooms* of this chapter for minimum size requirements.

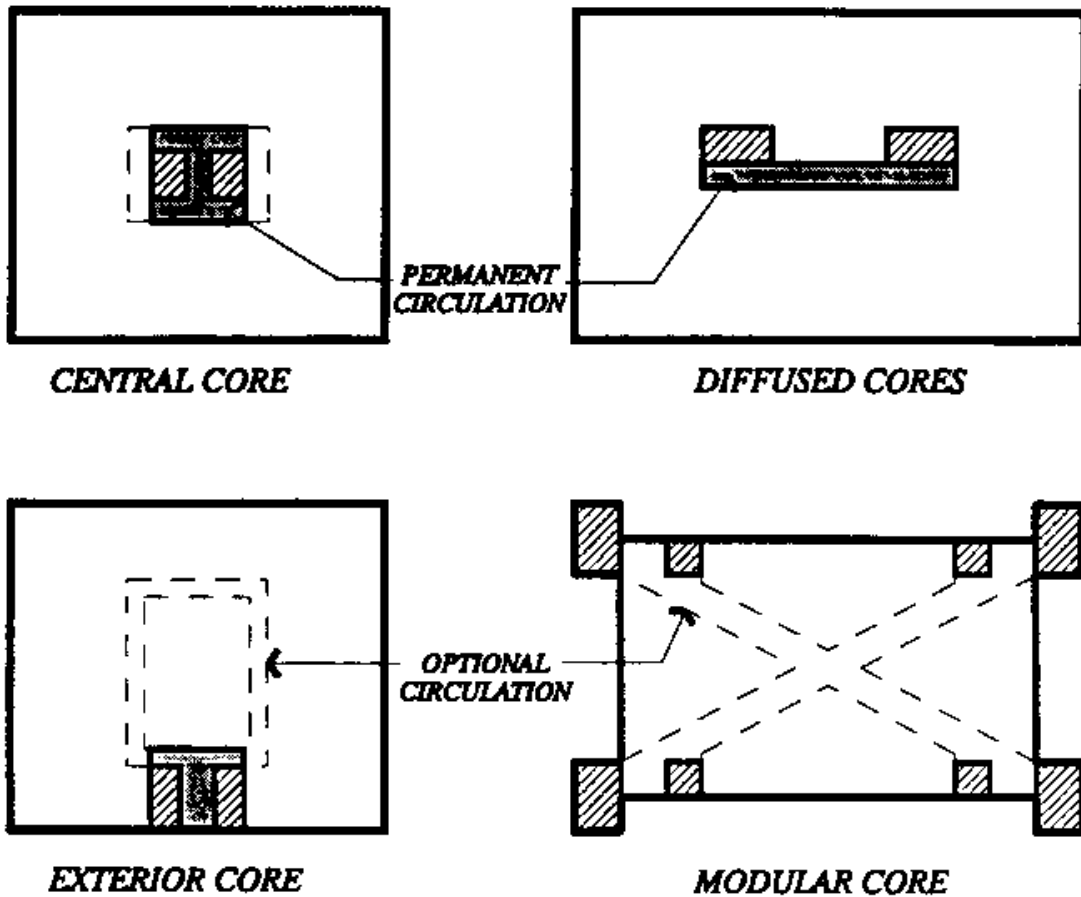

Figure 3-4  
Core Arrangements

**Occupiable Area and Net Usable Space.** Both of these terms have been coined by GSA to define building "tenant" space: *Occupiable Area* applies to GSA-owned buildings and consists of the total net floor area (including shared facilities, such as cafeterias and auditoria) less cores as defined herein, loading docks and permanent circulation. *Net Usable Space* is essentially the same as *Occupiable Area*, but applies to building space leased by GSA from the private sector. See Figure 3-5. In both cases the area occupied by perimeter heating units is deducted if these units occupy at least 50 percent of the length of the exterior wall.

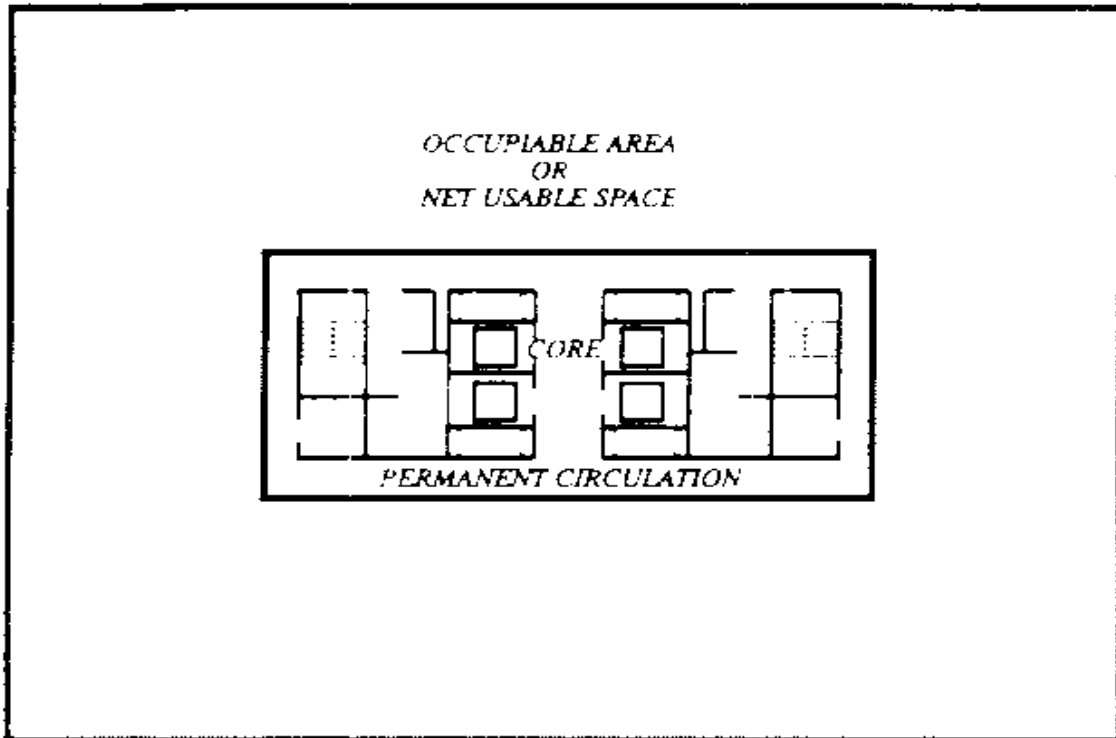

Figure 3-5  
GSA Occupiable Area or Net Usable Space

**Building Efficiency.** One of the goals in Federal building design is the efficient utilization of space. Building plans should be reasonably compact. A high net to gross ratio is desirable; however, it should not be achieved at the expense of well designed lobbies, circulation and support space.

The net to gross ratios expressed in Table 3-1 establish the general goals for Federal facilities:

Table 3-1  
**Minimum Net to Gross Ratios**

Building Type	Minimum Ratio
Office Buildings	75%
Courts	67%
Libraries	77%

---

## **Selecting Conveying Systems**

ANSI Standard A17.1 applies to the design of all elevators, lifts and escalators.

The selection of type and quantity of conveying systems, such as elevators, escalators and wheelchair lifts, must be preceded by a thorough traffic analysis of the facility. The following criteria should be used in this analysis.

**Elevator Classifications.** Public passenger elevators transport pedestrian traffic and an occasional small cart such as a mail cart.

Service elevators transport passengers and all other types of traffic. The use of service elevators is not recommended when freight movement would interfere significantly with passenger service.

If no separate freight elevator is provided, one passenger elevator must be designated as a service elevator with pads to protect the interior wall surfaces of the cab. A minimum ceiling height of 2 700 mm is required in service elevator cabs. Freight elevators should have a ceiling height of 3 700 mm.

Freight elevators exclusively transport freight, operators, and freight handlers. Freight elevators should be located remote from public elevator lobbies. Freight elevators should have sufficient capacity to transport replacement parts for building systems, such as compressors, motors, fans and small tanks, as well as other similar loads specified in the project program.

Security elevators transport designated groups of people such as judges, cabinet members or prisoners.

Shuttle elevators transport passengers from parking areas to the entrance lobby. Shuttle elevators must be used in all GSA buildings that have parking levels.

**Elevator Design.** The location of each elevator core should be coordinated with the horizontal traffic flow and with the means of ingress and egress.

The traffic analysis should anticipate elevator traffic composition. Separate calculations must be made for passenger and for freight or service (combination of passenger and freight) traffic. Freight elevators should be considered in buildings over two stories in height.

Each elevator should be considered to carry 80 percent of its rated load capacity during the up-peak period. Modifications to the transfer times for service (freight) traffic should conform to the types of equipment used.

The type of building occupancy will determine the probable number of stops used in the traffic analysis calculations. A single-tenant building will require a greater probable number of stops than a multi-tenant building. This is especially true when balanced two-way traffic is considered because the incidence of inter-floor traffic is much greater in a single-tenant building.

The anticipated elevator population should be calculated based on the occupiable floor area of the building and a factor of 14 m<sup>2</sup> per person. It should be assumed that 8 percent to 10 percent of the resulting population will not require elevator service during the peak periods.

If the building design requires two or more elevator banks, the population calculation results should be apportioned by functional layout of the building. These divisions should then be assigned to the appropriate elevator banks. For this purpose an "elevator bank" is defined as a group of adjacent or opposite elevators that function under a common operational system.

The criteria by which the traffic analysis calculations should be judged are "average interval" and "handling capacity."

Average interval is defined as the calculated time between departures of elevators from the main lobby during the a.m. up-peak period. Calculated intervals during the up-peak period should not exceed 30 seconds for a typical elevator bank.

Handling capacity is defined as the number of persons the elevator system must move in any given 5-minute period of up-peak traffic. GSA buildings should always be designed for a 20 percent handling capacity, even if the building is designed as a multi-tenant facility.

The traffic analysis should determine the quality, capacity and speed requirements of elevators. The capacity and speed are the limiting factors used in determining the minimum number of cars that will meet both the average interval and handling capacity criteria. If there are parking levels in the building, a separate analysis should be prepared for the shuttle elevators connecting parking levels with the lobby.

Capacities of 1 360 kg to 1 810 kg should be used for passenger elevators. Capacities below 1 360 kg are not suitable and above 1 810 kg are too expensive for a typical office building. Elevator cab sizes should be in accordance with the standards established by the National Elevator Industries, Inc. (NEII). Elevator cabs should be designed to reflect the architectural character of the building design.



Where the total number of floors served by the elevator system exceeds the practical limits of travel for a single elevator group (about 15 floors), the elevators should be arranged in low-rise, mid-rise, and high-rise configurations. Low-rise elevator groups are defined as serving the main lobby and floors up to about the 15th level. Mid-rise elevator groups are defined as those elevators serving the main lobby and levels 16 through 30, approximately. High-rise elevator groups are defined as those elevators serving the main lobby and levels 31 through 45.

If the building has more than 45 floors, express shuttle elevators should be considered to serve the group of floors above 45.

**Escalators.** Escalators should be installed as supplements to elevators when vertical transportation is required for a large *unpredictable* volume of public traffic. GSA prefers to use escalators only where absolutely necessary because of high maintenance costs. They should be used where the first floor is not large enough to contain the high public traffic so that the interval for elevators can be calculated with accuracy. Escalators must not be substituted for stairs.

Table 3-2  
**Criteria for Design of Escalators**

<u>Escalator Width</u>	<u>Capacity in Persons Per Hour</u>	<u>Capacity in Persons Per 5 Mins.</u>
820 mm	3,000	250
1 200 mm	4,000	400

Escalators should be located to be visible from the building entry and convenient to the areas they serve.

**Wheelchair Lifts.** Wheelchair lifts should not be used in new construction. Vertical or inclined wheelchair lifts should be considered in alterations, where ramps or elevators for handicapped use are impractical. Their number and location depends on the individual project. The lift should consist of a horizontal platform enclosed by a combination of panels, railings, doors, a lifting mechanism to raise and lower the platform, and suitable key control and safety devices.

## **Planning Module**

A planning module is defined as an imaginary grid that prescribes the location of repetitive elements such as columns in new buildings, partitions, ceiling grids, light fixtures, air diffusers, sprinkler heads and electrical outlets. A 600 mm by 600 mm planning module should be used in GSA buildings unless the designer can demonstrate a *long-term* efficiency of another size.

**Structural Bays.** Structural bay size should be based on the building configuration, architectural expression, seismic zone, functional efficiency and cost. Bay size must, of course, be evaluated together with the material proposed for the structural frame. Generally, larger bay sizes offer more planning flexibility than smaller ones; conversely, smaller bays may be more economical than larger bays. In any event, the structural bay size should be a multiple of the planning module in new buildings.

If no parking is included in the building structure, the 7 200 mm by 9 600 mm bay and 6 000 mm by 12 000 mm bay are practical choices. If space layout flexibility is a prime objective, the 10 800 mm by 10 800 mm bay is a good choice. This bay size can result in higher initial cost, but the flexibility and operational efficiency could outweigh the additional cost.

Some structural bay sizes can adversely affect parking layout. The 6 000 mm by 6 000 mm bay is too narrow for a two-way driveway aisle, which requires a minimum width of 7 050 mm. Some of the larger bays cannot be efficiently adapted to parking layouts. Transfer beams or inclined columns would have to be used to adjust the column spacing. If a major parking facility must be integrated with the office structure, the 9 000 mm by 9 000 mm bay is recommended. See Figure 3-6.

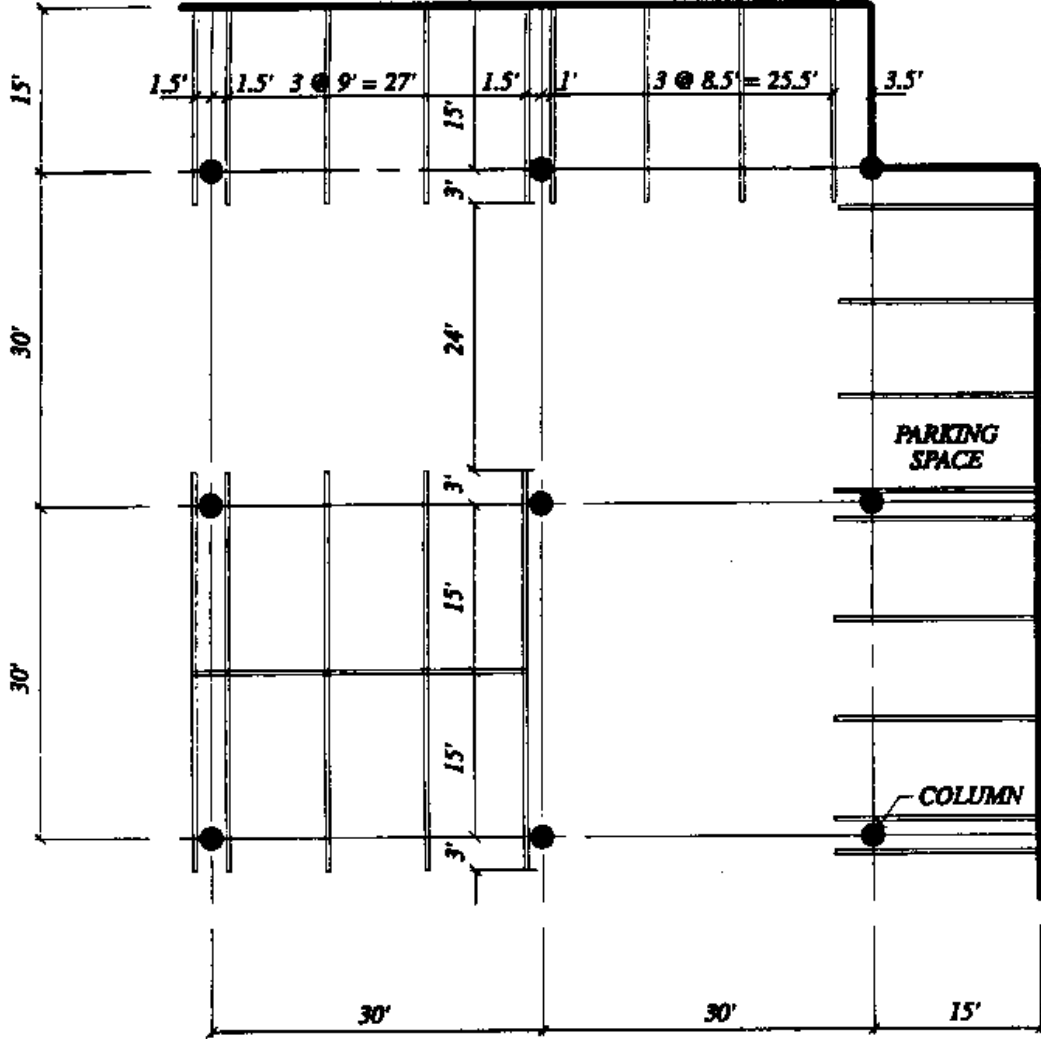
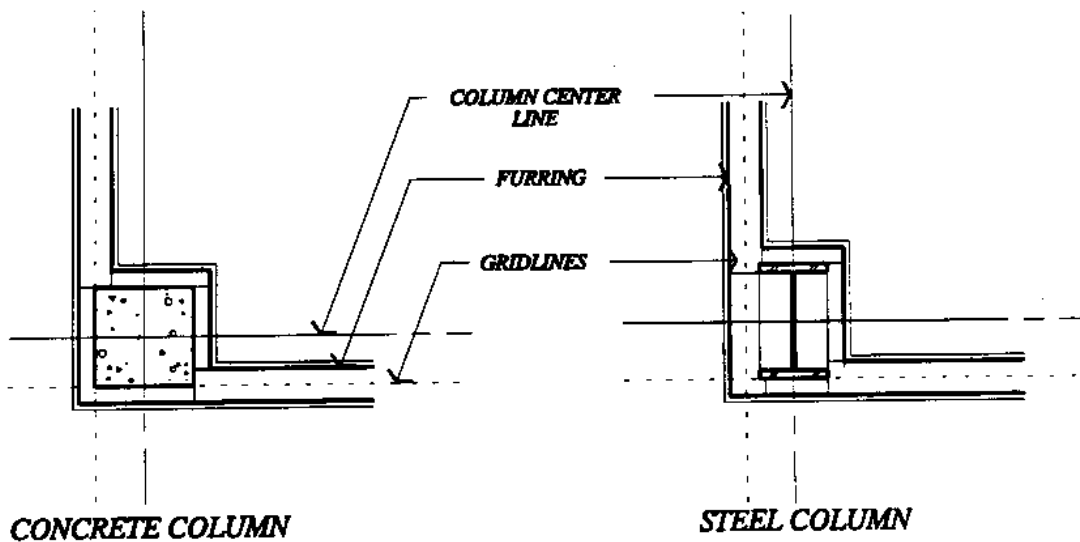

Figure 3-6  
Integration of Parking into 9 000 mm by 9 000 mm Structural Bay

**Column Placement within Planning Module.** Concrete columns should be located so that two of the edges line up with the grid lines. This placement facilitates space planning layouts and allows for furring. Steel columns, similarly, should be offset from the grid so that the furring around the column aligns with the future wall location, which is centered on the gridline. See Figure 3-7.

It should be noted that the placement of columns within the planning grid does not prevent the designer from using the column centerline as the starting point for construction dimensions.

Round columns are generally not recommended within office spaces because they are



difficult to integrate with systems furniture layouts.

Figure 3-7  
Column Placement and Grid Lines

**Perimeter Columns and Plan Layout at Exterior Wall.** The relationship of the planning module to structural bays and perimeter column placement has a critical impact on the efficiency of office space layouts and the design of the perimeter heating and cooling systems. The perimeter zone of the building and the HVAC system need to be studied in concert with the mechanical engineer at the concept stage in order to determine the best approach for perimeter column placement. Figure 3-8 illustrates three possible approaches

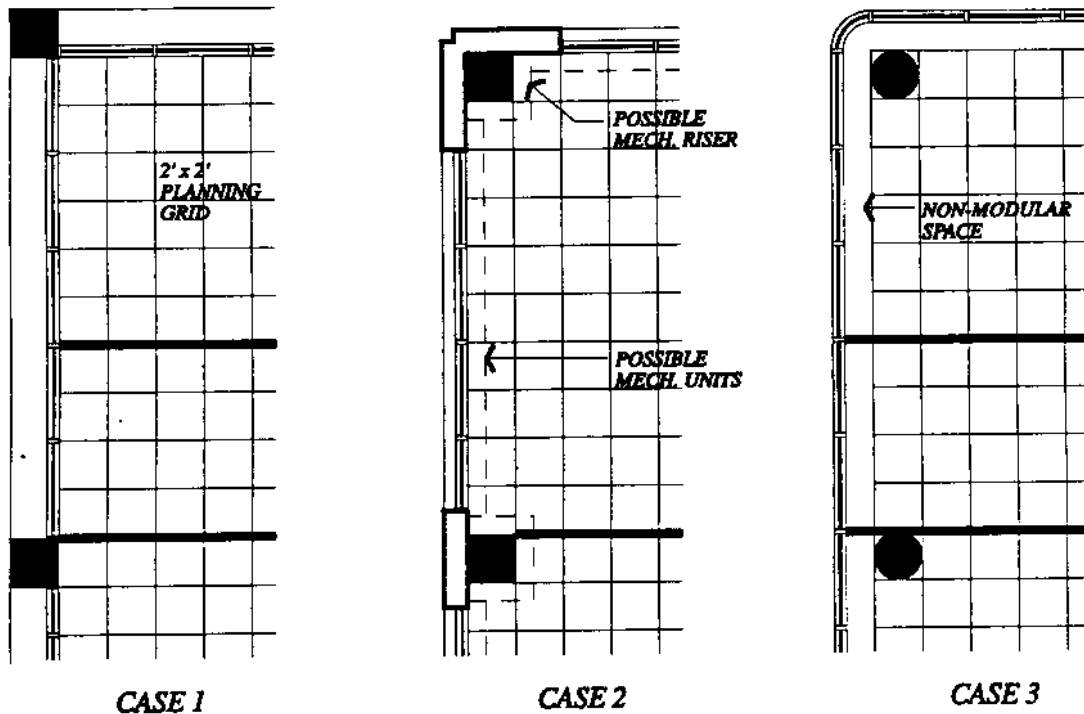

for perimeter column placement.

Figure 3-8  
**Perimeter Column Placement**

In case 1 the structural elements, columns and spandrel beams are external to the building skin and planning grid, and do not intrude into any office space. This is ideal for space planning, but creates a very deep exterior wall or expresses the building structure on the exterior façade. Either of these can be quite costly.

In case 2 there are minimal intrusions by structural elements. Mechanical risers and perimeter units can be suitably incorporated.

The layout shown in case 3 creates a non-modular space at the building perimeter. The columns intrude into the floor area making it less usable, particularly for small office layouts. This placement permits special treatment of the building perimeter and may be justified in some instances. If more than 50 percent of the length of the non-modular perimeter space is occupied by HVAC fixtures, it becomes non-assignable space. It will be excluded from the area for which GSA can charge rent.

Intersection of partition and exterior wall should occur where the exterior wall is solid or at window mullions. Dog legs are undesirable and should be avoided.

**Floor to Floor Heights and Vertical Building Zoning.** A total integration of all building systems - architectural, structural, mechanical, electrical and communications -will provide for current operations as well as for future changes. Floor to floor heights are determined by the depth of space required for structural, mechanical, electrical and communications systems.

Three options exist for delivering power and communications to general office areas: raised access floor, cellular floor duct, and underfloor duct encased in concrete deck. Figures 3-9, 3-10 and 3-11 illustrate the three concepts. After decades of experience with moves and changes within Federal office space, GSA now provides a general life cycle cost study to determine which of these three options should be used. See Chapter 6: *Electrical Engineering, Placing Electrical Systems in Buildings, Horizontal Distribution of Power and Communications.*

*FACILITIES STANDARDS FOR THE PUBLIC BUILDINGS SERVICE*

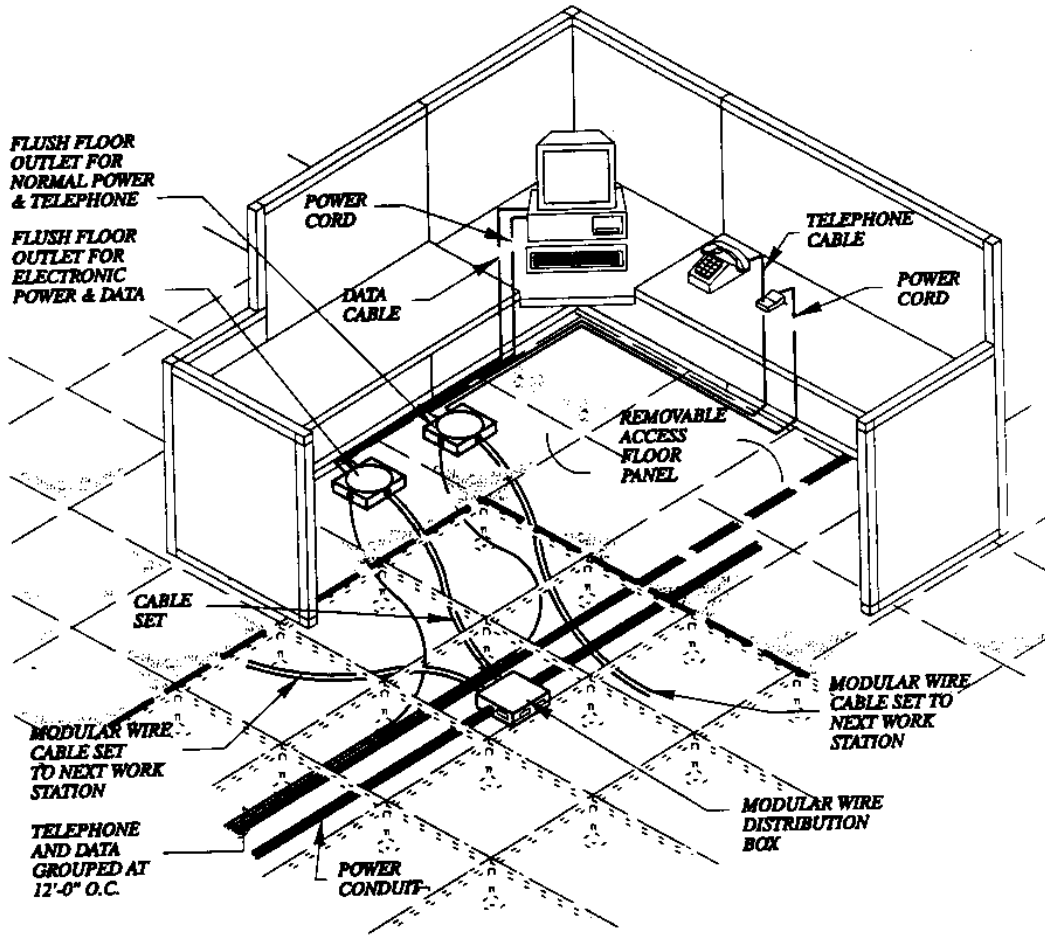

Figure 3-9  
Raised Access Floor Delivery



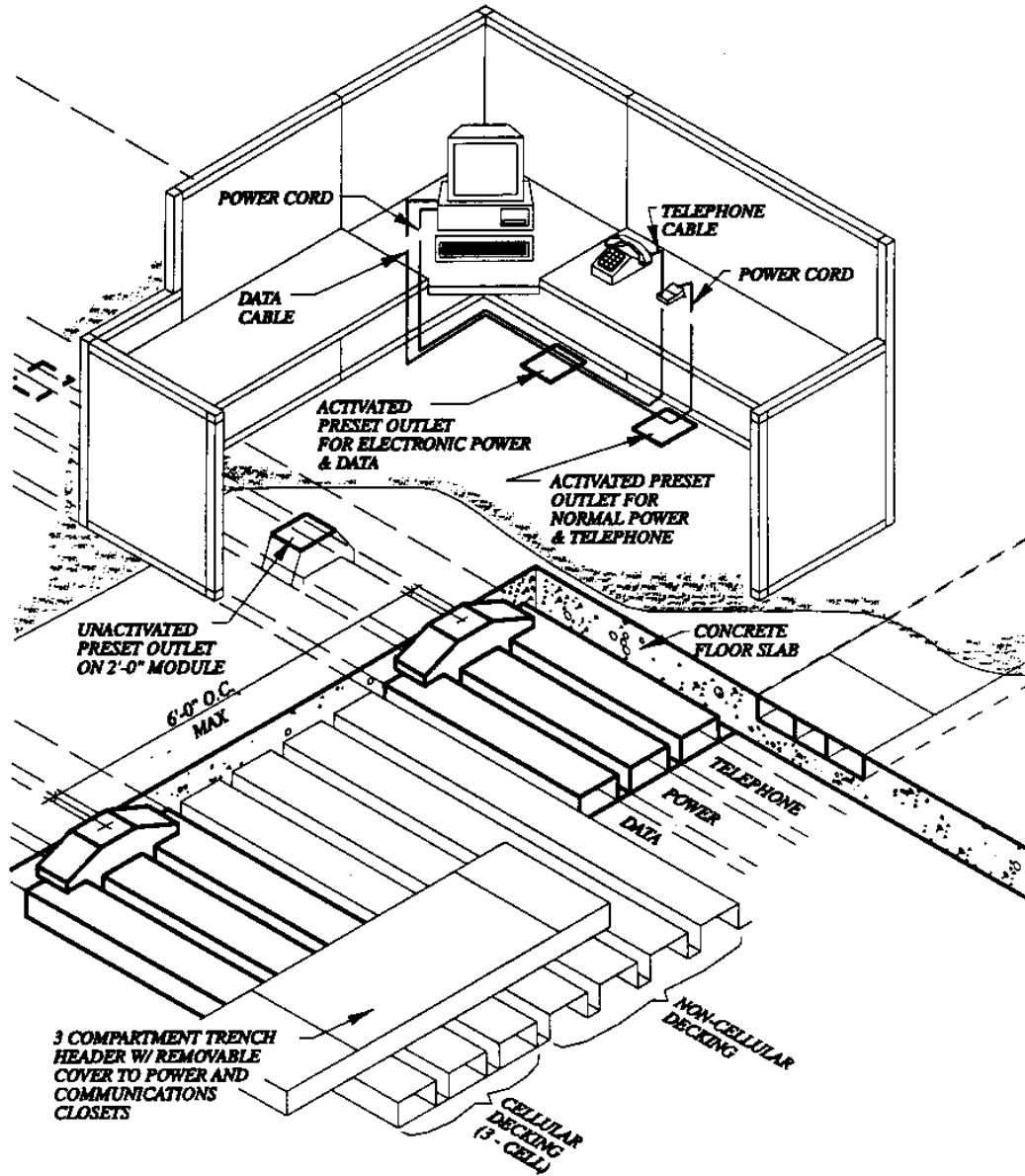

Figure 3-10  
Cellular Floor Duct Delivery

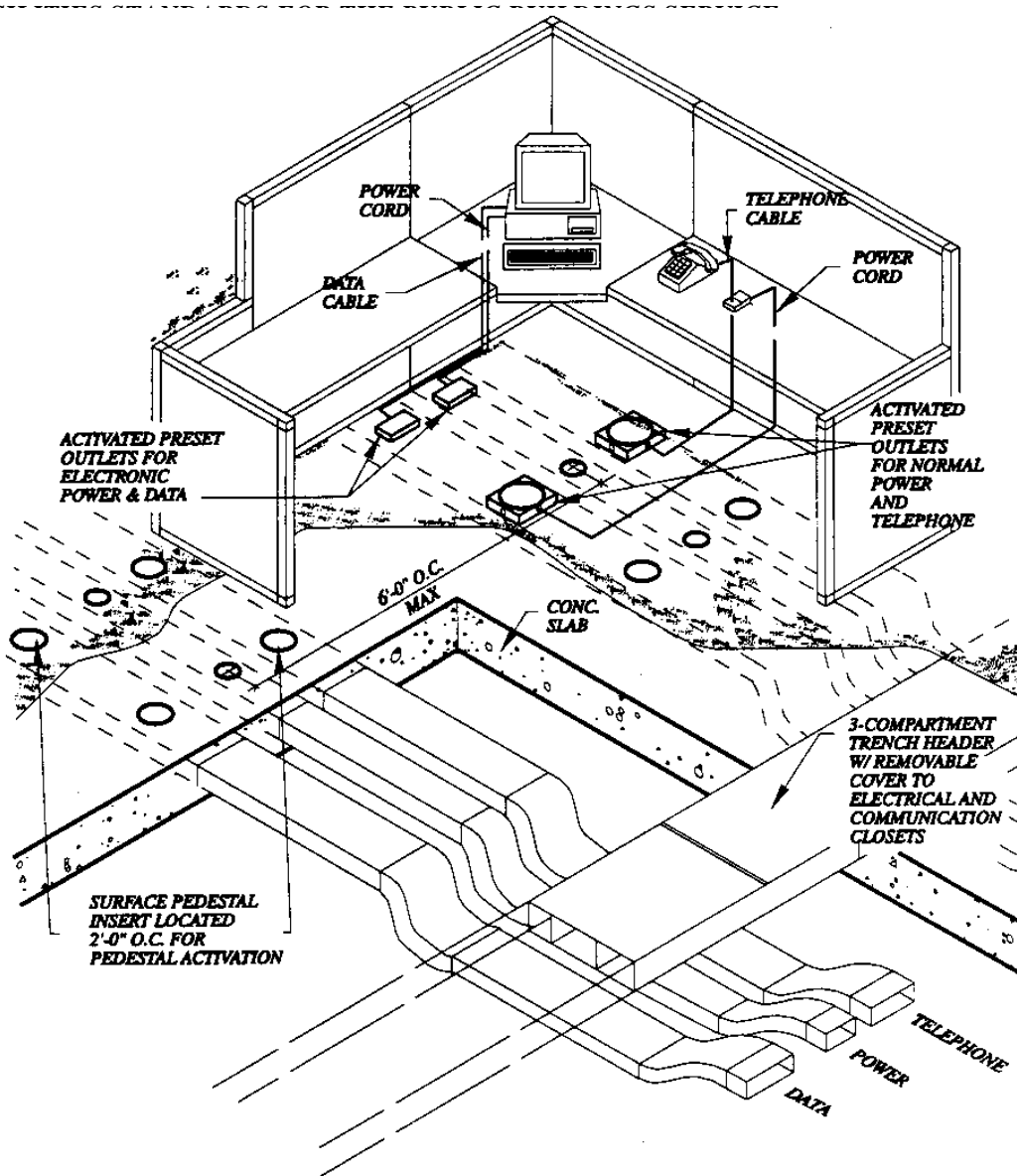

Figure 3-11  
Underfloor Duct Encased in Concrete

### ***CHAPTER 3. ARCHITECTURAL AND INTERIOR DESIGN***

---

The vertical zoning of the floor-to-floor space for horizontal utility distribution must be analyzed. The underfloor zone is reserved for power, telephone and data cabling, which is placed in groups of three at fixed intervals.

The ceiling space should be layered with the sprinkler piping zone near the underside of the structure or within it, the HVAC duct zone in the middle and the lighting zone immediately above the ceiling level.

The depth of the ceiling and floor space must be determined early in the design, in order to arrive at the floor-to-floor height of the building. It needs to be based on preliminary estimates of systems designs. Enough space must be left between the HVAC and lighting zones to accommodate future lighting moves and changes without moving other components. See Chapter 5: *Mechanical Engineering, Placing Mechanical Systems in Buildings, Vertical Zoning of Floor-to-Floor Space*.

The underfloor zone should be as deep as the sum of all the required cross-overs plus tolerances. Bear in mind that raised access floor panels are themselves 50 mm deep. The minimum depth of the total raised access floor, including panels, is 200 mm.

Figure 3-12  
**[Reserved]**

## Building Fire Protection

See Chapter 7: *Fire Protection Engineering, Architectural Requirements* for building fire protection requirements.

## Seismic Design

Seismic design is discussed in detail in Chapter 4: *Structural Engineering*. A few important architectural considerations that influence the conceptual design are restated here.

The effect of lateral forces on the structural system must be considered during development of the initial concept of the building. This may save effort later and result in an improved seismic design without detracting from the function of the building.

**Layout.** The plan configuration has a bearing on a building's resistance to seismic forces. Buildings that are asymmetrical in plan have greater susceptibility to damage than those that are symmetrical about one or two axes. Asymmetry in plan can be eliminated by separating L-, T-, and U-shaped buildings into distinct units with seismic joints at junctions of the individual wings.

**Buildings in Zones of High Seismicity.** In earthquake zones 2B, 3 and 4, asymmetry in plan and vertical discontinuity should be avoided. The concept design must be carefully reviewed by the structural engineers to ensure that a sound seismic design can be achieved. See Chapter 4: *Structural Engineering, Building Configuration in Earthquake Zones*.

Seismic design of nonstructural elements is discussed in detail in Chapter 4: *Structural Engineering, Attachment of Nonstructural Elements*.

## **Security Design**

Specific criteria for site and building security are described in detail in Chapter 8: *Security Design*. Some of the planning concepts are stated here because of their importance to building planning, but architects should familiarize themselves with Chapter 8 before developing schematic design concepts.

**General Layout.** Many future security problems can be prevented by planning a clear, simple circulation system that is easy for staff and visitors to understand. Avoid mazes of hallways and hidden corners. Exterior doors should be readily visible.

**Planning for Future Security Provisions.** All Federal buildings should be planned to allow for future controlled access, both to the entire building and to individual floors.

**Site Design.** Building entrances should be designed to make it impossible for cars to drive up and into the lobby. Concrete planters make excellent barriers; bollards are also acceptable if well integrated with the design of the building entrance.

**Building Entrances.** GSA buildings should have one main entrance for staff, visitors and the public. In large buildings a second entrance may be designated for employees only. Buildings may have additional doors used for egress or access to service areas. These doors should not be used as entrances. See Chapter 8: *Security Design, Basic Security Requirements for GSA Buildings, Basic Security System Choices* for access controls and intrusion detection systems.

**Building Lobby.** The building lobby should always be designed to permit subdivision into a secure and a non-secure area. The two areas could potentially be divided by turnstiles, metal detectors or other devices used to control access to secure areas. There should be space on the secure side for a control desk and an area where bags can be checked. Mechanical ductwork, piping and main electrical conduit runs should not extend from one area to the other. See the section *Space Planning, Public Spaces, Entrance Lobby and Atria* of this chapter.

**Shops.** Generally, shops should be located on the non-secure side of the lobby. Exceptions could exist where commercial establishments serve the building population only. Some buildings may have multiple levels of retail around an atrium. In that case, the security checkpoint should be located at the elevator lobby.

**Elevators.** Elevators serving the upper levels should be visible from the lobby and arranged so at least one car can be designated for secure traffic in the future. This elevator should be accessible from the future secure side of the lobby only.

Generally, elevators should not travel between the parking levels and the upper floors of a building. A separate bank of shuttle elevators should connect the parking garage with the "non-secure" side of the lobby only. Employees and visitors then pass to the secure side and take elevators to the upper floor of the building.

In some instances, multi-tenant buildings may house very security-sensitive agencies and require special consideration, such as direct access from office levels to parking levels. If that is the case, it will be indicated in the program. To accommodate high security tenants in GSA buildings (immediate or future), one of the elevator shafts in the bank serving the upper floors should be extended down to the parking levels. This shaft would be blocked off at the parking levels until required by a particular tenant. Once this elevator is in operation, it should be accessible by key, card or key pad only.

Elevator control panels must have lockout provisions for all floors (passenger and freight). Typically, card readers should be built into the control panel for employee access during off hours. See Chapter 8: *Security Design, Building Security, Elevators*.

**Mechanical and Electrical Spaces.** Access to mechanical and electrical spaces should be from the inside of the building, located on the secure side of the (potential) security point in the building lobby.

## Space Planning

### Office Space

**Floor and Ceiling Grids.** All walls and ceiling height partitions should be centered on the planning grid. See section *Building Planning, Planning Module* in this chapter. This permits the highest degree of flexibility in determining the size of individual work stations.

The grid for raised access flooring (i.e., the alignment of pedestals in both directions) should be offset from the planning grid by 75 mm in both directions to facilitate future removal of floor panels and to avoid excessive cutting of panels in instances where

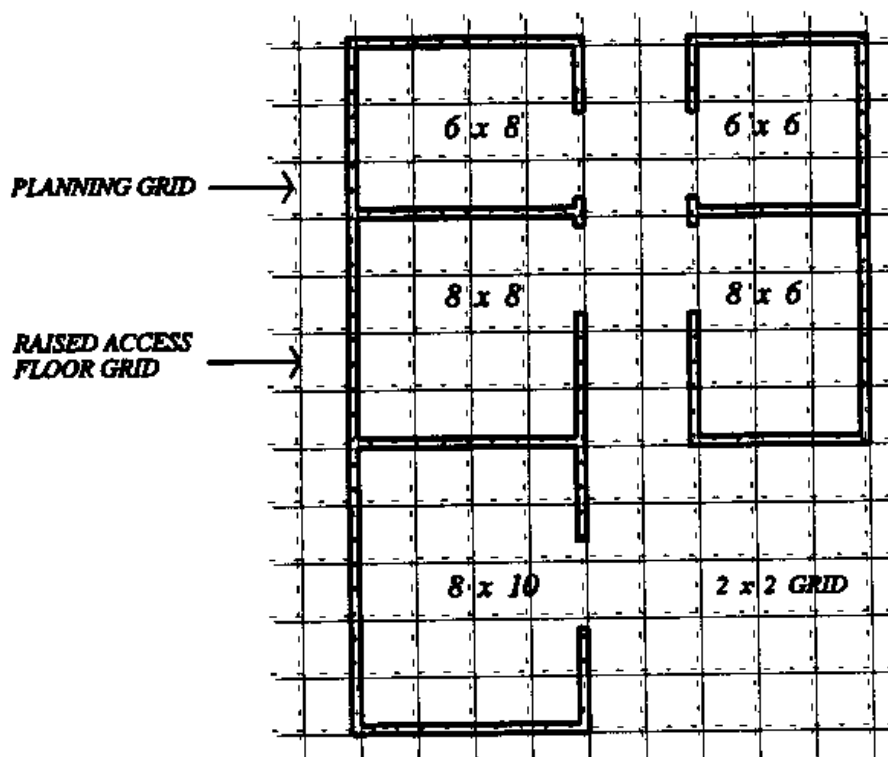

partitions must extend to the structural slab. See Figure 3-13.



Figure 3-13  
**Planning Grid, Raised Access Floor Grid and Work Stations**

Table 3-3  
**Typical Sizes for Work Stations**

Open Plan Systems Furniture	Closed Offices
1 800 mm x 1 800 mm	2 400 mm x 3 000 mm
1 800 mm x 2 400 mm	3 000 mm x 3 000 mm
2 400 mm x 2 400 mm	3 000 mm x 3 600 mm
1 800 mm x 3 000 mm	3 600 mm x 3 600 mm
2 400 mm x 3 000 mm	3 600 mm x 4 200 mm
3 000 mm x 3 000 mm	3 600 mm x 4 800 mm
mm	mm
etc.	

Work stations may consist of closed offices or open plan systems furniture. The planning grid applies to either case. The planning grid will be used most efficiently if work stations are laid out in a rectilinear pattern. However, with careful space planning, the same grid can be used to achieve diagonal, curved or other plan configurations for the work stations. If the layout is non-rectilinear, half-height partitions are more desirable.

**Closed Offices Versus Open Plan.** The open plan approach (with a very limited number of ceiling height partitions for offices) is encouraged. It has a higher degree of efficiency and flexibility, and provides easier distribution of natural light, heating and cooling to the working areas. This approach can be adapted to a larger building depth and still present an open and airy atmosphere. It also encourages interaction between individuals and work groups.

An open plan approach provides less acoustical control, less visual privacy and less environmental control than closed offices. These drawbacks can be countered effectively by creating closed rooms for functions that are either particularly noisy or require special acoustical privacy. Examples are rooms housing copiers and conference rooms.

The design of all building systems needs to be flexible enough to accommodate either type of plan in future alterations. Table 3-3 provides a comparison of typical work station size for the open plan concept and the closed office approach.

The average net work station size in a Federal building is 7m<sup>2</sup>. This demonstrates that small work stations are in the majority. The typical density of the *occupiable floor area* is one person per 14m<sup>2</sup>.

**Utility Placement.** General office space requires the following utilities: power, telephone, data lines, HVAC supply and return, fire sprinklers, public address systems and lighting.

The underfloor zone is reserved for power, telephone and data cabling. These services are grouped together and laid out so that the centerline of the three always falls 300 mm off the planning grid line.

The ceiling grid is offset from the floor grid by 300 mm in both directions, so that the top of a wall never falls on the ceiling grid. See Figure 3-14. This allows more choices in placing ceiling elements, such as lights and diffusers.

HVAC diffusers and return air grilles would normally be located within the 600 mm by 600 mm ceiling framing. If slot diffusers are used, as in integrated ceilings, they can be placed on the grid line. Experience has shown that a staggered diffuser layout in a uniform pattern adapts most easily to future changes in wall configurations.

Branch sprinkler piping should always be located 75 mm off the ceiling grid line and sprinkler heads should be placed in the corner of the ceiling tiles.

Lights would normally be located within the field of the grid, whether they are 600 mm by 600 mm or 600 mm by 1 200 mm fixtures. Downlights and pendant-mounted lights would fall within the field of the grid.

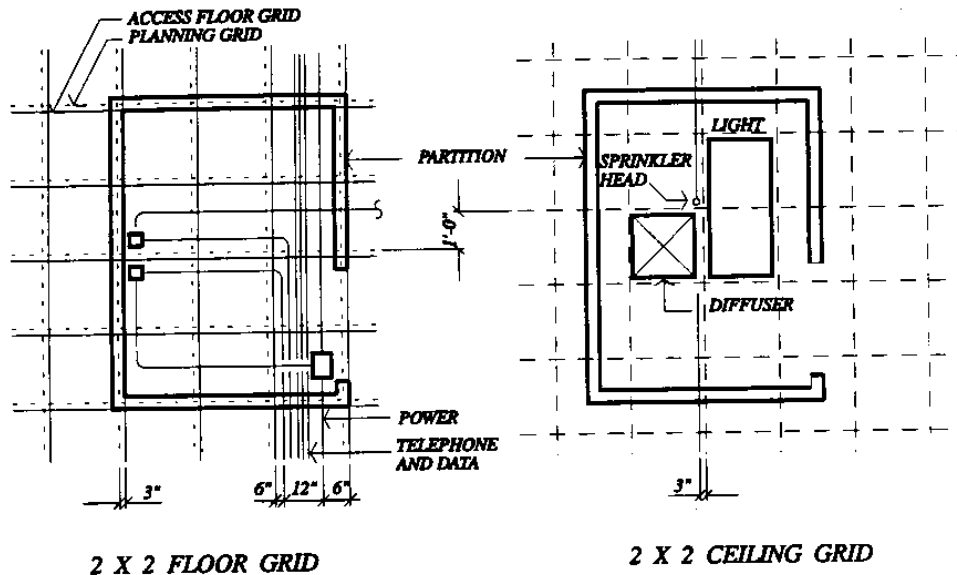

Figure 3-14  
Floor and Ceiling Grid

**Ceiling Height.** Above all, the general office space should have a uniform ceiling height to provide flexibility for future floor plan changes.

The clear ceiling height for office spaces is a minimum of 2 700 mm for spaces that are larger than 14m<sup>2</sup> (occupiable). The clear ceiling height of individual office rooms not exceeding 14m<sup>2</sup> (occupiable) is a minimum of 2 400 mm. The clear ceiling height of private toilets and small closets which are ancillary to other office spaces is a minimum of 2 300 mm.

**Doors.** Doors leading to any office space and communicating doors between office spaces must have a minimum nominal width and height of 900 mm by 2 100 mm.

**Automated Data Processing (ADP) Areas.** The special requirements listed here apply to areas housing *mainframe* computers, as distinct from rooms where plotters, disc drives and printers may be grouped. ADP spaces require access flooring over a plenum space, even if access floors are not used elsewhere in the building. They also need temperature and humidity control, acoustical isolation and absorption, security provisions, and usually require an uninterruptible power supply (UPS).

The access flooring of ADP areas should be level with adjacent spaces and must always be level with the landings of elevators that serve the ADP facility. Ramps should only be used where it is impossible to adjust the level of the structural floor. Where ADP areas occupy 33 percent or more of a floor, the entire floor, including internal corridors, should be designed with raised access flooring to accommodate ADP facility expansion. The floor levels of access flooring should be constant throughout the floor.

**Training and Major Conference Rooms.** Individual training and conference rooms may be located within the building to best suit the tenant. If such spaces are grouped to form a large training or conference facility, they should be located near the ground floor to avoid excessive loading of vertical transportation and to provide immediate egress for large groups of people.

Rooms designed for video tele-conferencing or training must have a minimum clear ceiling height of 3 000 mm.

**Internal Corridors.** For efficiency, internal corridors should be minimized.

**Planning Tenant Layouts.** Agencies that receive many visitors should be located on the level of the main entrance if possible. Location on the second floor with access by a monumental stair or escalator is the next best alternative. Agencies that have special security requirements should be located on upper levels.

Consideration should be given to potential expansion of tenant space within the building, particularly spaces for large tenants. These tenants should not be located next to immovable elements such as cores and building equipment space.

## **Public Spaces**

Public spaces are those accessible to the general public. They include entrances, lobbies, stairways, public elevator and escalator lobbies, and the permanent corridors at each floor level.

**Entrances and Vestibules.** The main entrance to a Federal building must be conveniently located for vehicular and pedestrian traffic. The entrance should be clearly visible and distinctive. It should serve both visitors and employees. All designated entrances should be accessible to the handicapped.

A canopy, portico, or arcade should be used for weather protection, and to emphasize the main entrance or enhance the building design.

Approaches must be well lighted and designed to direct the visitor to the entrance. Grade level approaches are preferred over elevated approaches that require steps. Both daytime and nighttime conditions need to be considered in the design. Clear and attractive graphics should be provided to assist visitors with directions. Landscape features should complement and enhance the building approaches and entrance.

Vestibules or revolving doors must be provided at the main building entrance to prevent the infiltration of cold air and drafts. Vestibules are preferred for ease of access by handicapped persons and better temperature control. Doors in entrance vestibules should be offset to mitigate drafts through the vestibule when both the inner and outer vestibule doors are open at the same time. Raised thresholds should not be used at doorways.

Automatic doors should be used on the main entrance of all large office buildings. Where they are used, adequate clearances are required for the proper operation of actuating and safety devices without interference from internal or external cross traffic. Automatic sliding doors are preferred over automatic swinging doors. Swinging automatic doors should swing in the direction of traffic. Safety devices should be considered to prevent a person from being struck by a swinging door.

In small buildings, power assisted doors may be used instead of automatic doors.

**Entrance Lobbies and Atria.** A main lobby is the formal reception area of a Federal building. Like the entire building, it should project an image of dignity and refinement. The lobby should be clearly visible from the outside, both day and night, and present a welcoming image to the public.

The main lobby should accommodate visitors by providing information facilities, waiting areas and access to vertical transportation. Since the lobby also serves as the collection point for all employees entering the building, it should be designed to accommodate the high volume of pedestrian traffic. Areas such as cafeterias, auditoria and exhibition halls should be located near the lobby.

Even in non-secure buildings, lobby space should be planned to accommodate a future security station, which may include an identity check, bag check, metal detector and turnstiles. Also allow for adequate queuing space on the future non-secure side of the lobby. Refer to Chapter 8: *Security Design, Building Security, Building Entrances, Building Lobby* and the section on *Building Planning, Security Design, Building Lobby* of this chapter for further details.

The size and volume of the lobby should be in proportion to the scale of the building, the function of the lobby and the expected pedestrian traffic.

A multi-level lobby or atrium should be designed for buildings where there may be a high volume of pedestrian traffic to levels above or below the entrance or for buildings with entrances at different building levels. Other situations that may justify an atrium are a prominent location, a building size of more than 23 200 m<sup>2</sup> (gross) or exceptional exterior views. When a multi-level lobby or atrium is used, monumental stairs, escalators or both may also be used if justified by the amount of pedestrian traffic between the two entrance levels.

Mechanical, electrical and communication systems must be integrated into the lobby design. Fixture and outlet locations, and forms, sizes, finishes, colors and textures of exposed mechanical and electrical elements must be coordinated with all other interior elements. It is desirable to conceal HVAC supplies and returns. Lighting should be part of the lobby architecture. Indirect and spot lighting should be considered. Incandescent fixtures must be limited to accent lighting.

Directional graphic systems, which lead visitors from the outside through the entrance to the main lobby and then to various departments, should be clearly visible, easily understood and consistent with the interior design. Agency emblems, exhibit stands, artwork and indoor landscaping should be designed to contribute to the total spatial aesthetic.

**Elevator and Escalator Lobbies.** Like entrance lobbies, elevator and escalator lobbies should be designed to efficiently accommodate the movement of pedestrian traffic to other parts of the building. Adequate space should be provided to perform this function. The lobby width between two elevator banks should be a minimum of 3 000 mm. Elements which create queues, such as exhibits or building directories, should not be placed in the immediate vicinity of elevator or escalator landings.

The elevator and escalator lobbies should be close to the main lobby and be visible from the main entrance. Visual supervision and physical control of the lobbies for elevators and escalators should be a prime consideration for building security.

Floors, walls and ceilings of elevator lobbies should be designed as an extension of the main lobby. Details, such as elevator doors, frames, call buttons and hall lanterns, should be integrated into the total design.

**Stairways.** Stairways will generally fall within three categories: monumental, communicating and emergency egress. These stairs should have the following characteristics:

*Monumental Stairs.* Monumental stairs are typically substantial in width, have high quality finishes with finely detailed design, and serve floors or mezzanines with high pedestrian traffic. Their design should be consistent with the architectural character of the spaces within which they occur. These stairs should have lower risers and wider treads than other stairs.

*Communicating Stairs.* Communicating stairs connect the various offices and spaces within the building and are used by the building occupants in their daily routine. Such stairs are integral spaces within a department. Therefore their design should be consistent with the spaces they serve.



*Emergency Egress Stairs.* Emergency egress stairs should be incorporated into the design for use as communicating stairs wherever possible so the building occupants will become familiar with their location and stairway use can be maximized. In this case, design the stairs to the communicating stair standards. Stairs used only to exit the building in an emergency should be utilitarian with minimal architectural treatment.

**Public Corridors.** Public corridors allow public access to the reception areas of the Federal agencies housed in the building. Generally, they are the most remote areas that the public may use without supervision. Public corridors are always part of the permanent building circulation and should be designed as an extension of other public spaces in the building.

A clear hierarchy should be visible in the treatment of spaces and corridors as they lead visitors from the entrance lobby to the main corridors and finally to departmental corridors. Each element of the circulation system should be of a quality compatible with the space in which it occurs. The entrance lobby should include the highest quality of finish and detail in the building. The main elevator and escalator lobbies should be consistent in design with the entrance lobby. Set deeper into the building, the upper-level elevator lobbies and public corridors should have a lower level of design detail, but should recall the elements of the main lobby.

Public corridors will almost always be exit corridors and must, therefore, meet the requirements of the building code in terms of minimum width. However, the general image of public space in the building should be maintained in these spaces. They must be of ample width and height, even if the dimensions exceed those required by code, to accommodate the public in a commodious manner. In general, a width of 1 800 mm should be the minimum.

In some large buildings long corridors are unavoidable. Corridors more than 18 000 mm in length should be broken up visually by introducing alcoves, ceiling projections, light coffers or other special fixtures, banners or sectional wall and floor patterns. See Figure 3-15.

It is desirable to introduce as much natural light as possible into corridors, through windows, transoms or borrowed lights.

*F*

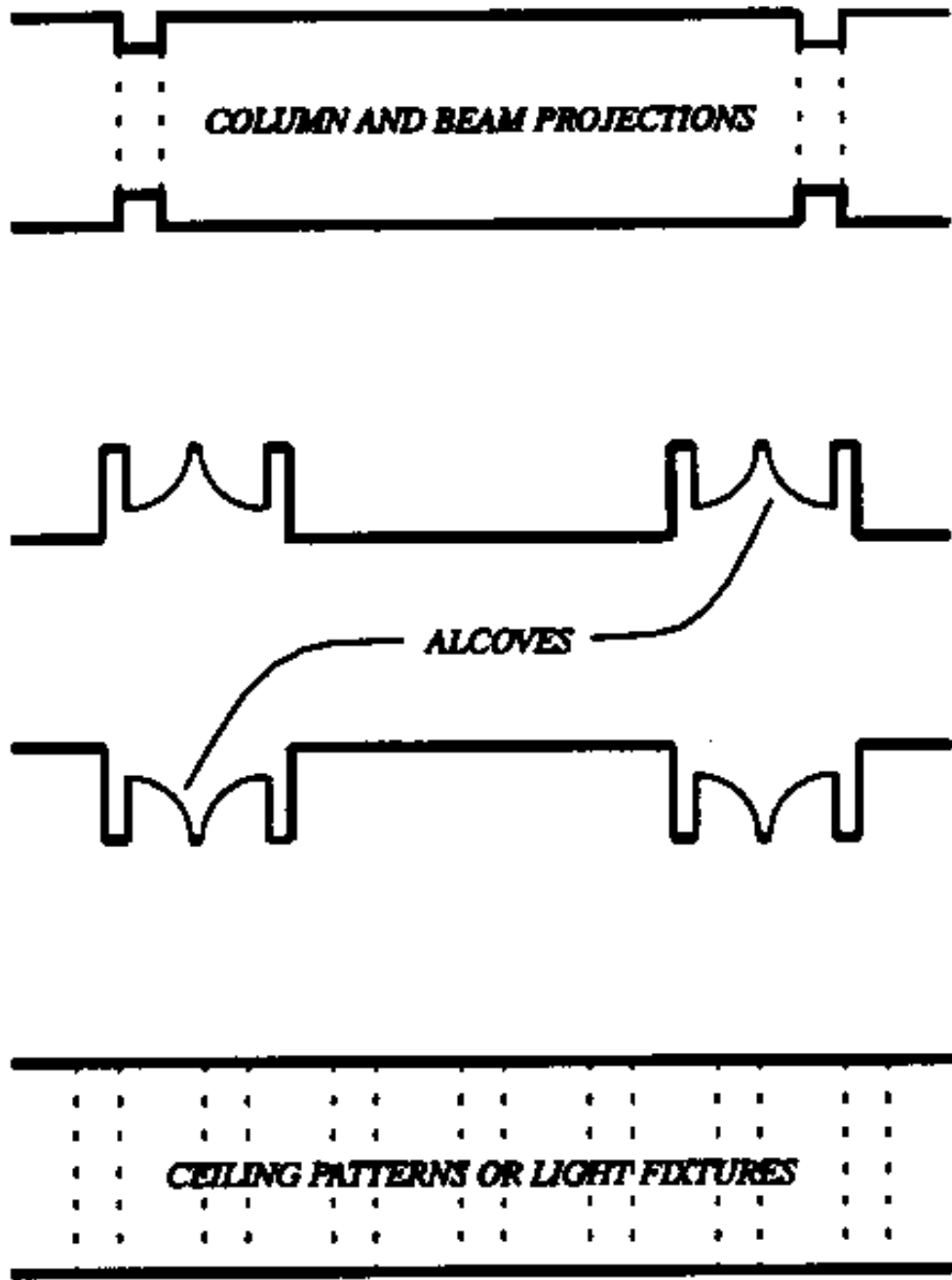

Figure 3-15  
Corridor Articulations

**Pedestrian Tunnels and Bridges.** The architectural treatment of tunnels and bridges should be similar to that of public corridors. Changes of level should be accomplished by ramps with a maximum slope of 5 percent and be part of a route accessible to the disabled. Tunnels should be designed with special lighting and artwork to enhance the experience of people traveling through them.

Bridges require special treatment to reduce glare and possible acrophobia. Where glazing extends to the floor, rails should be provided. Skylit roofs must be glazed with low emissivity glazing to reduce solar heat gain. Continuous skylights are preferred over individual skylights within an opaque roof. Structural systems must strictly limit deflection of the supporting floor deck.

## **Building Support Spaces**

**Toilet Spaces.** Toilet space includes general use toilets and associated vestibules, anterooms and contiguous lounge areas.

The number and location of toilet rooms should maximize convenience for occupants and the general public. At least one men's and one women's toilet room should be provided on each floor of a building. Toilet rooms for both sexes should also be located adjacent to the cafeteria. See section on *Building Planning, Placement of Core Elements and Distances* in this chapter for maximum travel distances to toilets.

Toilet rooms should be screened from public view without the use of double door vestibules at entrances. All public and common use toilets must have facilities for the disabled. All other toilets must have provision for future adaptation to handicapped access.

To the extent possible, toilets should be grouped to reduce plumbing runs. The layout of toilets should minimize circulation space. However, toilet rooms for assembly areas, such as training or conference facilities, must accommodate short-term, high-volume traffic. Circulation should be adequate to handle peak traffic.

The number of toilet fixtures to be provided is based on the occupant load for the floor. For office buildings, calculate one person for each 14 m<sup>2</sup> of occupiable area or net usable space. Buildings with large footprints may require more than one set of toilet rooms per floor. Assume a ratio of 50 percent men and 50 percent women for calculation purposes, unless the building program states otherwise. Table 3-4 states the minimum number of toilet fixtures to be provided in office buildings. For building types other than office buildings, the number of fixtures should be based upon the national code used.

Table 3-4  
**Number of Toilet Fixtures**

No. of Persons Per Toilet Room	Men			Women	
	WC	Ur	Lav	WC	Lav
1 to 8	1	1	1	2	1
9 to 24	2	1	1	2	2
25 to 36	2	1	2	3	2
37 to 56	3	2	2	4	3
57 to 75	4	2	2	5	4
76 to 96	4	2	3	6	5
97 to 119	5	2	3	7	5
120 to 134	6	3	4	8	5
Above 135	1/20	1/40	1/30	1/15	1/24

**Modular Toilet Room Option.** Increased awareness of the needs of handicapped users, even-handed provision of facilities to both sexes, and considerations of security, privacy and convenience have led to the development of new concepts for the planning of toilet facilities.

Suggested for consideration as an alternative to conventional multi-stall toilet rooms is a program of "modular" single-fixture toilet rooms. These rooms may be provided in groups or individually, whichever may be most appropriate for a particular planning condition.

The modular unit, which is illustrated in Figure 3-16, is square in plan, 2 400 mm by 2 400 mm, or 6 m<sup>2</sup>. Plumbing fixtures are standard, with the lavatory preferred as a drop-in type set in a level counter. The room should be provided with an annunciator which controls a light fixture mounted over the door outside the room. The fixture should indicate whether or not the room is "occupied." The room should also be provided with a smoke detector and a panic/duress alarm activated by a button or switch adjacent to the toilet.

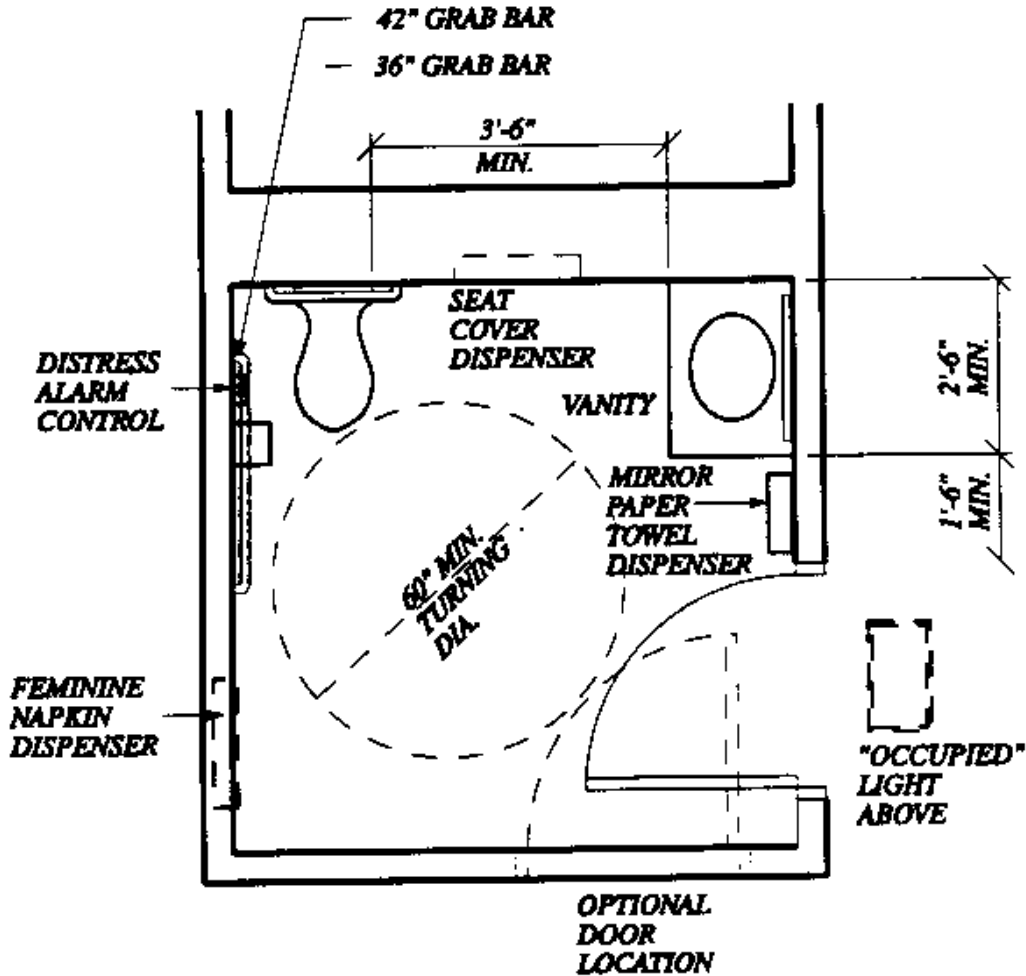

Figure 3-16  
**Modular Toilet Room Plan**

If the modular toilet concept is used, Table 3-4 does not apply. The number of toilet fixtures need not exceed those stipulated by the national code used. From a study performed for GSA, it appears that fewer fixtures will be required in the building overall when the modular concept is used. Thus, provision of the modular units will likely require less gross floor area than the conventional approach. See figures 3-17 and 3-18 for core plan examples comparing a modular toilet arrangement with a conventional toilet room layout.

*CHAPTER 3. ARCHITECTURAL AND INTERIOR DESIGN*

---

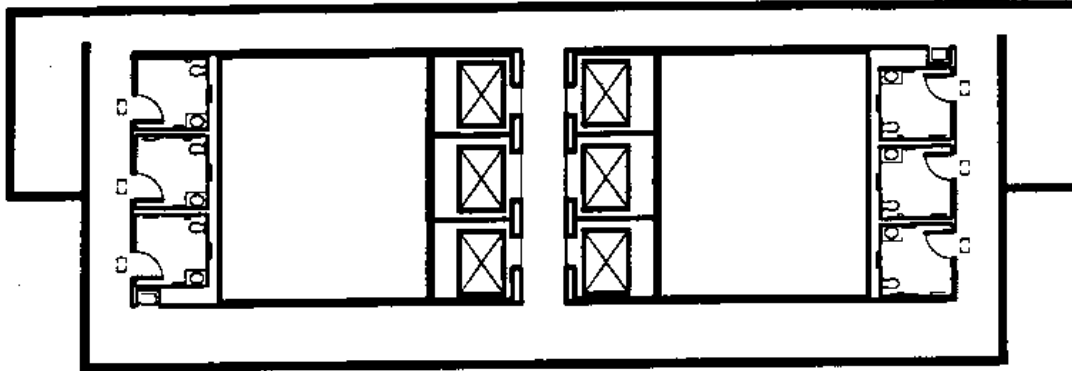

Figure 3-17  
Example of Core Plan with Modular Toilet Rooms

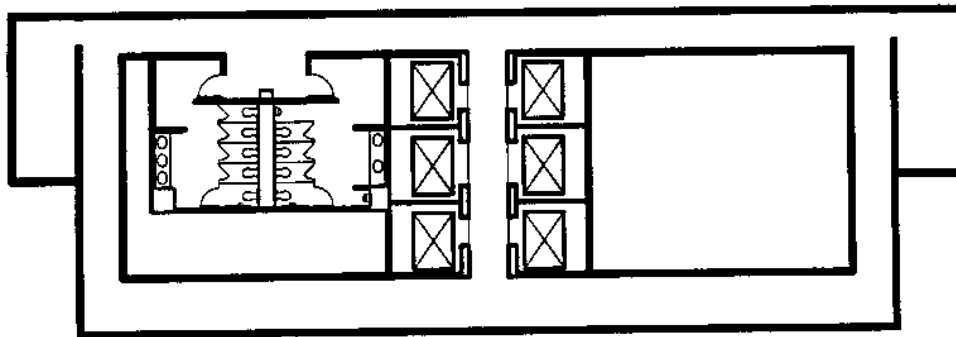

Figure 3-18  
Example of Core Plan with Conventional Toilet Rooms



The following are seen as potential advantages to the modular program:

- Equal access to toilet facilities for all building occupants (handicapped, male, female).
- Greatly enhanced flexibility in planning of facilities.
- Opportunity, through decentralization of toilet facilities, to improve convenience and efficiency of facilities.
- Increased personal security while using toilet facilities.
- Increased privacy while using toilet facilities.

**Staff Locker Rooms.** Staff locker rooms should be finished spaces. Vented lockers should be provided for each member of the staff, with space adequate for a complete change of clothing. Locker rooms should contain sufficient seating area to accommodate all persons required to change clothing at a single time period. The shower area should be separated from the locker area. Regular gypsum wallboard should not be used as a substrate for any shower room surface. Portland cement board is preferred over water resistant gypsum board as a substrate.

**Custodial Spaces.** Custodial spaces are devoted to the operation and maintenance of the building and include building maintenance storage rooms, stockrooms and janitor's closets.

*Storage Rooms.* Storage rooms are utilitarian spaces. Rooms may be any configuration that will efficiently accommodate the materials to be stored. Access doors and aisles need to be large enough to move the stored materials.

*Janitor's Closets.* Janitor's closets should be centrally located on each floor near the elevators. They should accommodate all the equipment and supplies needed to service the area worked from the closet. All available space within the closet can be put to use to store gear and supplies. As a minimum, the service closet should have a 600 mm square mop basin, a wall mounted mop rack, and 900 mm of 250 mm-wide wall shelving; the floor area should be a minimum of 2m<sup>2</sup>.

**Mechanical and Electrical Rooms.** These spaces include mechanical and electrical equipment rooms, enclosed cooling towers, fuel rooms, elevator machine rooms and penthouses, wire closets, telephone frame rooms, transformer vaults, incinerator rooms, and shafts and stacks.

*Equipment Spaces.* Mechanical and electrical equipment rooms must be designed with adequate aisle space and clearances around equipment to accommodate maintenance and replacement. Hoists, rails and fasteners for chains should be provided to facilitate removal of heavy equipment. The working environment in equipment rooms should be reasonably comfortable. Doors and corridors to the building exterior must be of adequate size to permit replacement of equipment. This path may include knock-out panels, hoists and provisions for cranes if necessary. Mechanical equipment rooms should not be less than 3 700 mm clear in height. In some buildings special fire protection measures may be required. See Chapter 7: *Fire Protection Engineering, Architectural Requirements, High Severity Occupancies and Special Occupancy Requirements.*

All equipment spaces must be designed to control noise transmission to adjacent spaces. Floating isolation floors are recommended for all major mechanical rooms. See the section *Special Design Considerations, Acoustics, Design Criteria for Building Spaces, Class X Spaces* of this chapter for noise isolation criteria.

It is not advisable to locate the main electrical switchgear below toilets or janitor closets or at an elevation that requires sump pumps for drainage. If electrical switchgear is housed in the basement, provisions should be made to prevent water from flooding the electrical room in the event of a pipe breaking.

*Spaces for Uninterruptible Power Systems (UPS) and Batteries.* The UPS modules and associated batteries must be installed in separate, adjacent rooms.

See the UPS and battery manufacturers' installation instructions for weights, dimensions, efficiency, and required clearances in the design. Allow space for storage of safety equipment, such as goggles and gloves. Special attention should be given to floor loading for the battery room, entrance door dimensions for installation of the UPS and ceiling height for clearance of the appropriate HVAC systems.

*Electrical Closets.* Electrical closets must be stacked vertically within the building. See section on *Building Planning, Placement of Core Elements and Distances, Electrical Closets* in this chapter for spacing of electrical closets within the building. Closets should be designed to contain adequate wall space and clearances and should have a minimum size of 1 800 mm by 3 000 mm. Shallow closets must be at least 450 mm deep. They should not contain extraneous floor area, which may be an invitation to store items that do not belong in electrical closets.

*Communications Closets.* Communications closets must be stacked vertically within the building. See section on *Building Planning, Placement of Core Elements and Distances, Communications Closets* in this chapter for spacing of communications closets. Closets should be sized to contain adequate floor space for frames, racks and working clearances. The minimum closet size is 2 400 mm by 3 000 mm. Plywood boards should be provided on at least one wall for placement of telephone equipment. The design should comply with EIA/TIA 569: Commercial Building Standard for Telecommunication Pathways and Spaces.

*Vertical Shafts.* Vertical shafts for running pipes, ducts and flues should be located adjacent to other core elements to the maximum extent possible. Shafts should be straight vertical runs. Offsets in shafts should be avoided. Shafts should be sized to accommodate planned expansion of the systems. Shafts should be closed at top and bottom, as well as at the entrance to the mechanical room, for sound isolation. In some cases shafts may require special fire protection measures.

**Loading Docks.** Loading docks must be located for easy access by service vehicles and must be separate from the main public entrances to the building. Loading docks must be convenient to freight elevators so that service traffic is segregated from the main passenger elevator lobbies and public corridors. Loading docks must accommodate the vehicles used to deliver or pick up materials from the building. If the bed heights of vans and trucks varies more than 450 mm, at least one loading berth must be equipped with a dock leveler. The dock should be protected with edge guards and dock bumpers. Open loading docks should be covered at least 1 200 mm beyond the edge of the platform over the loading berth. In cold climates dock seals should be used at each loading bay. Alternatively, consideration could be given to enclosing the entire loading bay.

Separate loading docks should be considered for food service areas.

If the building size warrants, a dock manager's room or booth should be located so the manager can keep the entire dock area in view and control the entrance and exit from the building.

Loading docks should not be used as emergency egress paths from the building.

**Loading Berths.** Provide at least one off-street berth for loading and unloading. The berth should be 4 600 mm wide and at least as long as the longest vehicle to be accommodated. Local zoning regulations or the architectural program may require a longer length. The space should be located adjacent to the enclosed or open loading dock. If additional loading berths are required they need not be wider than 3 600 mm, as long as they are contiguous to the 4 600 mm wide berth.

An apron space should be provided in front of the loading berth for vehicle maneuvering equal to the length of the berth plus 600 mm. This area should be flat, with a minimum slope of 1:50 for drainage. The minimum headroom in the loading berth and apron space is 4 600 mm. When a steeper slope is required in the apron area, the headroom should increase with a gradient allowance - shown as "x" in Figure 3-19 - to allow trucks to traverse the grade change.

If the approach to the loading dock is ramped, the design should permit easy snow removal.

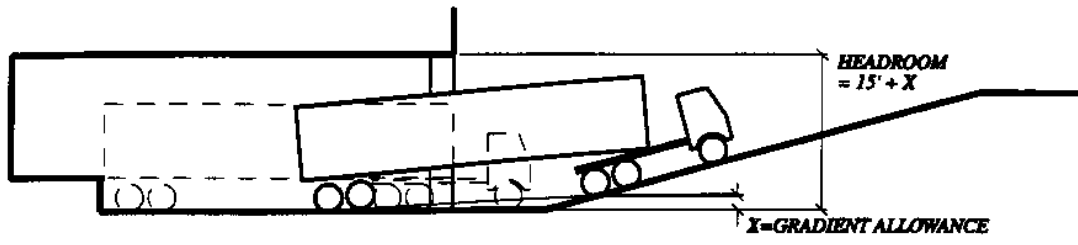

**SECTION**

(X) VERTICAL DISTANCE BETWEEN FRONT AND BACK TIRES

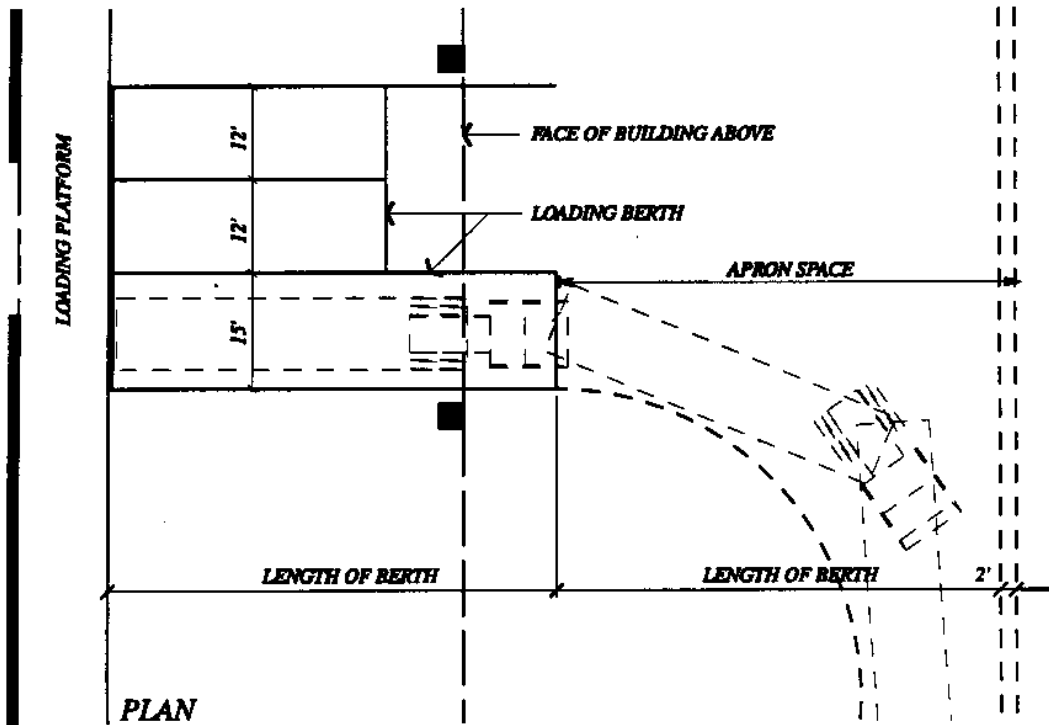

**PLAN**

Figure 3-19  
Loading Berth

**Staging Area.** A staging area should be provided adjacent to the loading dock. It must be protected from the weather. The staging area should not interfere with emergency egress from the building.

**Trash Rooms.** Trash rooms should be adjacent to loading docks or service entrances. Trash rooms must be sized to accommodate the trash handling equipment required and provide storage for packaged trash generated during a three day occupancy of the building. Space should be allowed for recycling of paper, glass and metals. Facilities that use trash containers that are picked up by vendors must have at least one loading berth for the trash container.

**Building Engineer's Space.** Even if not included in the building program, an office space for the building engineer should be evaluated. Most GSA buildings require such a space, which houses the consoles for the Building Automation System and possibly a read-out panel for the fire alarm and security systems. This space is normally located near the loading dock or main mechanical spaces.

**Security Control Center.** Even if not included in the building program, the need for a security control center should be evaluated. All GSA buildings with a local security force should have a control center. See Chapter 8: *Security Design, Security Systems design, Alarm Monitoring Stations and Control Centers*. In the event that the building will not be served by a local security force, this room could be combined with the building engineer's office or the fire control center.

The security control center should be located adjacent to the main lobby. It should have a clear view of the lobby, but should be as unobtrusive as possible when seen from the lobby space. Approximately 21 m<sup>2</sup> should be allocated for this room which is intended to house the command station for the security guards and their equipment for current as well as future building needs.

**Fire Control Center.** See Chapter 7: *Fire Protection Engineering, Architectural Requirements, Special Occupancy Requirements, Fire Control Center* for additional requirements.

## Specialty Areas

**Food Service Areas.** Generally, food service areas that are used by the building occupants and the general public should be located at the ground floor. This location provides an opportunity for exterior dining areas and reduces elevator and stair traffic. Food service storage areas should be adjacent to the food service loading dock. If the food service area is not on the same level as the dock, a special elevator or dumbwaiter should be provided. The entrances to the dining area should be visible from the main circulation paths, but should not impede lobby traffic.

Space allocations for food service facilities are established in GSA handbook, *Concession Management Desk Guide (PMFC-93)*.

Dining areas should be located to take advantage of natural light and outdoor eating areas in climates where this is feasible. Since they are an extension of the public spaces of the building, they should be dignified and graceful. Appropriate lighting should be integrated into the design.

Serveries should be laid out to minimize waiting times for customers. Scramble service is recommended.

**Child Care Centers.** See GSA *Child Care Center Design Guide (PBS-PQ140)*. Child care centers will usually be operated by organizations outside the Federal Government. The GSA Office of Child Care Development Programs should be consulted before design concepts are finalized.

**Laboratories.** If laboratories are an adjunct use in a mixed occupancy building, they must be located against an exterior wall of the building and must be separated from other occupancies by 1-hour construction, including Class C fire-rated doors. The construction of new laboratories in existing office buildings is strongly discouraged. See Chapter 7: *Fire Protection Engineering, Special Occupancy Requirements, Laboratories*.

**Outleased Space.** This term defines building space leased to businesses as commercial stores.

Outleased spaces and the connection between them and the remainder of the building should be designed so they can function as Government office space in the future.

## **Structured Parking**

The building program will stipulate the numbers and types of vehicle parking spaces. The program will also state whether parking is to be exterior on-grade parking or interior, structured parking. The following criteria apply to structured parking facilities and are minimum requirements. Dimensions apply to passenger cars and need to be modified for other types of vehicles.

**Parking Layout.** To the extent possible, parking spaces should be arranged around the perimeter of the parking deck for maximum efficiency. Two-way drive aisles should be used with 90-degree vehicle parking stalls on each side. When locating entrances and ramps, consider internal and external traffic flow, queuing during peak periods of ingress and egress, and required security features. See Figure 3-20.



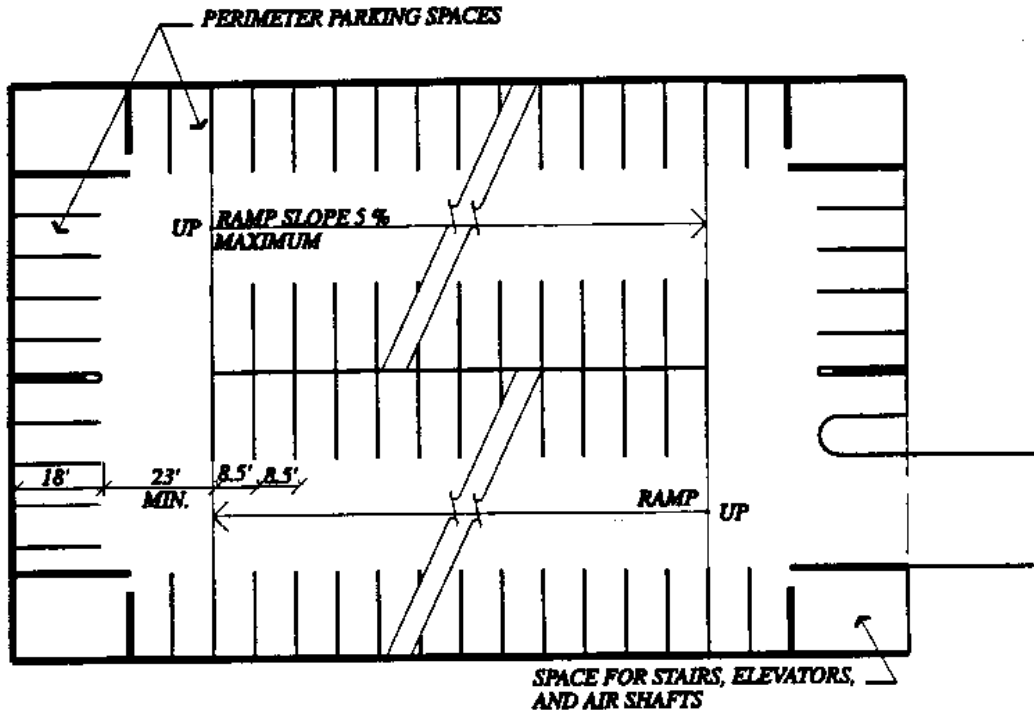
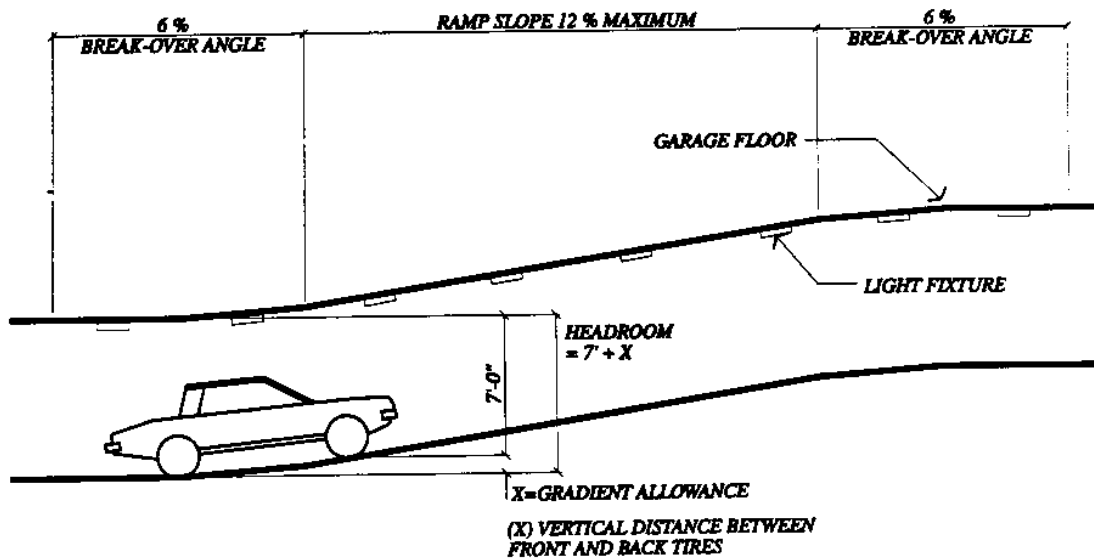

Figure 3-20  
Example of Parking Layout

**Drive Aisles.** Two-way aisles must have a minimum width of 7 000 mm. One-way aisles and aisles with stalls on only one side are less efficient and should be avoided.

**Vehicle Stalls.** Stalls to accommodate regular passenger cars should have a minimum size of 2 600 mm wide and 5 400 mm long. No special consideration should be given to compact vehicles. No structural element may intrude upon the required stall dimension, and columns must not be located within 600 mm of the required aisle except where the aisle has no stalls perpendicular to it. Each stall must have access to an aisle.

**Ramps.** The incline on parking area ramps should not exceed 6:50, as shown in Figure 3-21. The break-over angle at changes of plane in ramps should not exceed 3:50. The incline on ramp floor garages should not exceed 1:20. The entire length of the entrance and exit ramps must be protected by a building overhang so that snow and ice do not



accumulate on the ramps. Snow melting systems should also be considered.

Figure 3-21  
Parking Ramps and Headroom

**Stairs and Elevator Lobbies.** To enhance security, stairs and elevator lobbies serving the structured parking should be glazed and located so they can be observed from a public street.

**Walkways.** Pedestrian walkways should link the parking area with the building entrance. Provide curbs, bollards or low walls to prevent vehicles from encroaching upon pedestrian walkways. Identify pedestrian crossings of vehicular traffic lanes by painted crosswalks and signage.

## **Special Design Considerations**

### **Acoustics**

The standards in this section have been established to ensure adequate acoustics in Federal buildings.

**Parameters Used in Acoustic Design.** Acoustics, like room temperature, is an environmental condition. Every element of the space, its shape, surfaces, furniture, light fixtures and mechanical systems contribute to its acoustical characteristics. The following parameters are used to establish acoustical standards for GSA buildings:

*Ambient Noise Level.* This parameter refers to the level of noise within a space. Generally, the lower the level of ambient noise the more comfortable inhabitants will feel. On the other hand, mechanical sound is sometimes introduced into a space to mask background noise and/or raise the level of speech privacy. Ambient noise level is quantified by Noise Criterion (NC) Curves, published in ASHRAE Handbook of Fundamentals.

*Noise Isolation.* This parameter refers to the amount of noise transmitted through the perimeter of a space. The better the sound barrier, the higher its Sound Transmission Class (STC).

*Noise Isolation Class.* This is a classification established by ASTM E-336 for determining noise isolation between existing building spaces. A modification of this rating, *Speech Privacy Noise Isolation Class (NIC)*, is used to rate ceiling tile and free-standing space dividers in open plan office space.

*Reverberation Control.* Reverberation defines the amount and direction of sound reflected from a given material. A harder surface produces a reflected noise level. Soft surfaces absorb sound waves and reduce the ambient noise level. The ability of a given material to absorb sound is expressed by its *Noise Reduction Coefficient (NRC)*.

**Design Criteria for Building Spaces.** The most effective way to control noise propagation in buildings is to provide buffers between noisy and quiet areas. Buffers can be unoccupied space, shafts, filing or archive areas.

*Class A Spaces:* These are critical, noise sensitive spaces. The category includes auditoria and court rooms. The acoustical treatment of these spaces must be designed by a qualified acoustical consultant or specialist. U.S. court facilities must be designed in accordance with the AOC document *U.S. Courts Design Guide*. Technical criteria and design variables should be established by an acoustical specialist based on an analysis of the user's needs.

*Class B1 Spaces:* This category describes spaces where meetings take place on a regular basis, including conference rooms and training rooms. The design ambient noise level must not exceed NC 30. Air supply and return systems should be equipped with soundtraps or insulated ductwork to meet this criterion. Sound isolation at partitions enclosing Class B1 space is a minimum STC of 45. Doors must be gasketed. Acoustical ceilings must have a minimum NRC of 0.55 if the space is carpeted or 0.65 if not carpeted. Background masking should not be used.

*Class B2 Spaces:* This category consists of spaces where people are likely to speak in a higher than normal tone of voice and spaces where concentrations of noisy equipment are located, including dining areas, ADP areas, computer equipment rooms and rooms housing high speed copiers. The design ambient noise level must not exceed NC 40. Sound isolation at partitions enclosing Class B2 space must be a minimum STC of 45. Doors must be gasketed. Acoustical ceilings must have a minimum NRC of 0.55 if the space is carpeted or 0.65 if not carpeted. If background sound masking is used, the NRC criteria do not apply.

*Class C1 Spaces:* Enclosed general office space falls in this category. The design ambient noise level must not exceed class NC 35. Partition and ceiling assemblies must have a minimum STC of 40. Partitions should terminate at the underside of the ceiling. Floors should be carpeted, unless unusual circumstances exist. Acoustical ceiling units must have a minimum NRC of 0.55 if the space is carpeted or 0.65 if not carpeted. This does not apply to spaces with background masking systems.

*Class C2 Spaces:* This category describes open plan offices. The design ambient noise level must not exceed NC 35. Noise isolation must meet the requirements of at least NIC 20. Acoustical ceiling units must have a minimum NRC of 0.55 if the space is carpeted or 0.65 if not carpeted. Ceiling ratings do not apply to spaces with background sound masking systems.

Background sound systems can improve the speech privacy and reduce the perceived level of random noise. Studies indicate that people are most comfortable with low frequency sounds such as rustling leaves or a gentle surf. These sounds can be reproduced through loudspeakers at a uniform and unobtrusive volume level. The background masking system must be coordinated with the noise characteristics of the mechanical system to achieve a uniform sound pattern.

Where background sound masking is used, the system should be designed by a qualified acoustical consultant.

*Class D Spaces:* Occupied space where speech privacy is not a significant consideration, such as internal corridors, circulation stairs and file rooms, are part of this category. The same criteria apply as for Class C1, except that noise isolation is not a requirement.

*Class E Spaces:* These are public spaces and support spaces: lobbies, atria, toilets and locker rooms. The design ambient noise level must not exceed class NC 40. There are no specific sound isolation requirements, but Class E spaces should be separated as far as possible from quiet areas. In large lobbies, acoustical treatment should be provided on some surfaces to mitigate reverberation.

*Class F Spaces:* These are warehouses, parking garages and fire stairs not used for normal circulation. The design ambient noise level must not exceed NC 50. Class F spaces should be separated as far as possible from quiet areas.

*Class X Spaces:* These are spaces where noisy operations are located, including kitchens, mechanical, electrical and communications equipment rooms, elevator machine rooms and trash compactor rooms. The design ambient noise level has no fixed limit, but treatment should be considered if NC 60 is exceeded. Sound isolation between Class X spaces and other spaces should be a minimum of STC 45. Consideration must be given to sound transmission through floors and ceilings to spaces above and below. Sound isolation floors are recommended for all mechanical room floors where space below is occupied.

**Sound Isolation from Exterior Noise Sources.** The exterior construction systems recommended in these standards will screen out ordinary traffic noise. Buildings located near airports or other sources of high noise levels should have special exterior glazing and gasketing systems, designed with the assistance of a qualified acoustical consultant.

## **Fallout Protection**

Federal law requires that Federal buildings provide protection suitable for fallout shelters within program and budgetary limits. The program will state if shelters are required on a given project. Fallout shelters are not designated building spaces: they are spaces used for other purposes, which can serve as shelters in an emergency.

Shelter locations should be identified during the early stage of design. See Figure 3-22. Natural features of topography and adjacent buildings should be utilized to increase radiation shielding. The optimum shelter location is below grade. Basement levels, including underground parking facilities, offer good protection. In the absence of a basement, a partial depression of the first floor area would improve protection.

For above grade floors, building elements should be arranged to form a protected space within the core, with extra mass designed into surrounding walls, floors, and ceilings.

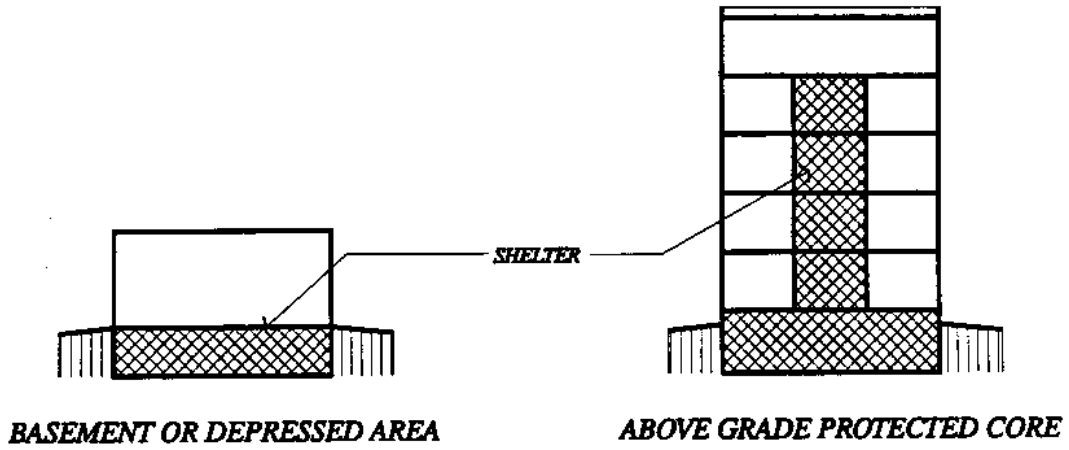

Figure 3-22  
Shelter Locations



## Building Elements

This section establishes design guidelines for the various building elements, which are defined as the physical parts of building construction. These may be individual materials, assemblies of materials, equipment, or assemblies of materials and equipment.

It is the architect's responsibility to specify construction materials and systems appropriate to the final design. For special requirements on fire protection see Chapter 7: *Fire Protection Engineering, Architectural Requirements*.

## Substructure

**Ground Water Control.** Where foundation drains are required, provide a drainage mat and soil filter from 100 mm below finished grade to at least 150 mm below the top of the foundation drain. The drainage mat and soil filter should relieve hydrostatic pressure on substructure walls and allow water drainage to the level of the drain. Drainage system piping may be clay tile or rigid PVC. Pipes should not slope less than 1:200. Subsurface drainage should discharge into the storm drain, by gravity if possible. Cleanouts should be provided at grade to facilitate washing out the system.

**Waterproofing.** Membrane waterproofing should follow the recommendations of the National Roofing Contractors Association (NRCA) as contained in NRCA publication, The NRCA Waterproofing Manual.

**Underslab Insulation.** Provide insulation under concrete slabs on grade where a permafrost condition exists, where slabs are heated, and where they support refrigerated structures.

## Exterior Closure

Products constructed of carbon steel are not permitted in exterior construction, which includes exterior walls, soffits or roofs, except where protected by a galvanic zinc coating of at least 460 g/m<sup>2</sup> of surface or other equivalent protection.

**Exterior Wall Construction.** Brick masonry design should follow the recommendations of the Brick Institute of America (BIA) contained in the publications, Technical Notes on Brick Construction.

Concrete masonry design should follow the recommendations of the National Concrete Masonry Association (NCMA) contained in the publication, TEK Notes.

Architectural precast concrete design should follow the recommendations of the Precast Concrete Institute (PCI) contained in PCI publication, Architectural Precast Concrete, Second Edition.

Exterior limestone veneer design should follow the guidelines of the Handbook on Indiana Limestone published by the Indiana Limestone Institute of America.

Marble veneer design should follow the recommendations in Exterior Marble Used in Curtain or Panel Walls published by the Marble Institute of America.

Vapor retarder must be provided in a building envelope where heat loss calculations identify a dewpoint within the wall construction and in any building or part of any building that is mechanically humidified.

**Cornerstone.** A cornerstone is required for all new buildings as a part of the exterior wall. The cornerstone should be a cut stone block having a smooth face of size adequate to present the following incised letters: UNITED STATES OF AMERICA, (PRESIDENT'S NAME), PRESIDENT, GENERAL SERVICES ADMINISTRATION, (ADMINISTRATOR'S NAME), ADMINISTRATOR, (YEAR OF PROJECT COMPLETION). The words, UNITED STATES OF AMERICA, should be in letters 50 mm high and other letters should be proportionally sized by rank.

**Commemorative Plaques.** Commemorative plaques which may be located on public spaces within the building should be compatible with the architectural style, scale and materials of the space. Lettering should be of a simple style and not oversized.

**Sun Control Devices.** Projecting exterior sun screens may be used in addition to interior sun control devices where they are beneficial for building operation and energy conservation. Exterior shutters, blinds and awnings should not be used.

**Exterior Soffits.** Design exterior soffits to resist displacement and rupture by wind uplift. Design soffits for access to void space where operating equipment is located or maintenance must be performed. Soffits can be considered totally exposed to weather and should therefore be designed to be moisture resistant. Provide expansion and contraction control joints at the edges and within the soffit. Spacing and configuration of control joints should be in accordance with the recommendations of the manufacturer of the soffit material.

Operating equipment or distribution systems that may be affected by weather should not be located inside soffits. Where it is necessary to insulate the floors over soffits, the insulation should be attached to the underside of the floor construction so that the soffit void may be ventilated to prevent condensation.

**Exterior Windows.** Generally, fixed windows should be used in large, environmentally controlled GSA buildings. In certain circumstances operable windows may be appropriate in border stations, other small buildings or buildings located in mild climates. Sometimes operable windows can also be used as a means of smoke control. In addition, operable windows may be used where they provide for window washing operations. In such cases, the operable windows should be able to be washed from the interior side.

Wherever operable windows are used, they should be key controlled. GSA's design criteria for HVAC will provide appropriate ventilation, ensure a satisfactory building environment and meet energy conservation requirements.

Aluminum windows should meet the requirements of ANSI/AAMA Standard 101-85. Only Optional Performance Classes may be used. Metal windows other than aluminum should meet the requirements of the National Association of Architectural Metal Manufacturers Standard SW-1 for the performance class required. Wood windows should meet the requirements of ANSI/NWMA Standard I.S. 2-87, Grade 60.

Aluminum frames must have thermal barriers where the number of heating degree days exceed 3,000. Window mullions, as much as possible, should be located on the floor planning grid to permit the abutment of interior partitions.

*Glazing.* The choice of single, double or triple glazed windows should be based on climate and energy conservation requirements. Highly reflective glass which produces mirror images should be used with care to avoid creating glare in surrounding streets and buildings.

*Condensation Resistance.* Windows should have a condensation resistance factor (CRF) adequate to prevent condensation from forming on the interior surfaces of the windows. The CRF can be determined by testing in accordance with AAMA 1502.7, Voluntary Test Method for Condensation Resistance of Windows, Doors and Glazed Wall Sections. Where a CRF in excess of 60 is required, do not use windows unless some condensation can be tolerated or other methods are used to prevent or remove condensation.

**Exterior Doors.** Entrance doors may be aluminum and/or glass of heavy duty construction. Unglazed exterior doors and frames should be steel and meet the requirements of SDI Grade III with a G-90 galvanic zinc coating. Sliding automatic doors are preferred over swinging type. Motion detectors and push plates are preferred over mats as actuating devices.

Revolving doors should have a minimum leaf size of 900 mm.

Overhead coiling doors are preferred for loading docks. At least one personnel door should be provided in addition to the overhead doors.

*Hardware for Exterior Doors.* Hinges, hinge pins and hasps must be secured against unauthorized removal by using spot welds or peened mounting bolts. All exterior doors must have automatic closers. The exterior side of the door should have a lock guard or astragal to prevent jimmying of the latch hardware. Doors used for egress only should not have any operable exterior hardware. See Chapter 8: *Security Design, Building Security, Building Entrances* for additional information.

Perimeter door locks must contain at least five-pin tumblers. Except for egress doors, all perimeter doors must have 25 mm deadbolt locks.

**Roofing.** Roofing design should follow the recommendations of the National Roofing Contractors Association as contained in NRCA publication, NRCA Roofing and Waterproofing Manual. The design of metal flashing, trim, and roofing should follow the recommendations of the Sheet Metal and Air Conditioning Contractors' National Association (SMACNA) publication, Architectural Sheet Metal Manual.

*Roof Drainage.* Dead level roofs are not permitted. Roof drains or scuppers are the only low points permitted. Provide a minimum slope to drains of 1:50 on roofing surfaces.

*Access to Roof.* An interior permanent stair should be provided to permit access to roof-mounted equipment.

*Roof-Mounted Equipment.* Roof-mounted equipment should be kept to a minimum and must be housed in penthouses or screened by walls. Penthouses and screen walls should be integrated into the building design and constructed of materials used elsewhere in the building exterior. Some roof-mounted equipment, such as antennae, lightning rods, flagpoles, etc., does not have to be screened, but these elements must be integrated into the building design.

No building element may be supported by the roofing system except walkways. Provide walkways on the roof along routes to and around equipment for maintenance. Where walkways are within 900 mm of a vertical drop of 300 mm or more, provide handrails.

**Skylights and Sloped Glazing.** Skylights are defined as pre-fabricated assemblies shipped ready for installation, while sloped glazing is defined as field-assembled. Skylights design should follow the guidelines of the AAMA Standard 1600. For the design of sloped glazing, two AAMA publications are available: Glass Design for Sloped Glazing and Structural Design Guidelines for Aluminum Framed Skylights.

Skylights and sloped glazing should use low emissivity glass. Placement should be calculated to prevent glare or overheating in the building interior. Condensation gutters and a path for the condensation away from the framing should be designed.

## **Interior Construction**

**Partitions.** Partitions should be selected for use based on the type of space and the anticipated activity within that space. The following should be evaluated: the volume of people; their activities; the type, size, weight and function of equipment (mail carts, forklifts, etc.) that will be used in the space; and any free-standing, moveable or wall-mounted equipment that will impose lateral loads (built-ins, wall-mounted televisions, etc.).

Each potential wall system must be evaluated for structure, backing, finish and protection factors. GSA prefers partition systems that are simple to construct, made from readily available materials, economical and easily moved and reassembled by common laborers. Metal stud systems must meet the requirements of ASTM C754. The application and finishing of gypsum board should follow standard ASTM C840. Adequate tolerances should be designed where the top of a partition abuts the underside of the building structure; allow for deflection and long term creep.

Partitions used at the perimeter of a humidified space must include a vapor barrier. In computer rooms the need for air plenum dividers below the floors must be checked.

**Interior Finishes.** Refer to the section on *Interior Finishes* in this chapter.

**Doors.** Interior doors in tenant spaces should be flush, solid-core wood doors. Steel door frames should meet the requirements of SDI Recommended Erection Instructions for Steel Frames. Provide matching-edge veneers for transparent-finished wood doors. Avoid the use of wood door frames except to match wood doors in specially designed areas.

**Ceiling Suspension Systems.** The design of suspension systems for acoustical ceilings must meet the requirements of ASTM C.635 for heavy-duty systems and ASTM C.636.

**Access Flooring.** If no load requirements are stated in the building program, design access flooring for 1210 kg/m<sup>2</sup> uniform load and 560 kg point load. Generally, floor panels should be concrete filled metal or concrete. Both pedestal and stringer systems are acceptable; however, for heavy cart traffic, stringer systems are preferred. The system must be coordinated with the design of the underfloor junction box for electrical power and communications.

Designs should be selected with an eye toward frequent removal and replacement of raised access floor tiles. Systems that require extensive bolting and unbolting are not desirable.

## **Building Specialties**

**Window Washing Equipment.** Generally, window washing and exterior maintenance are performed by maintenance contracting firms that provide their own powered platforms, scaffolding, or chairlifts to perform these functions. To accommodate the use of maintenance equipment suitable engineered systems shall be designed. The design will be for buildings three stories or 12 000 mm and higher, and shall conform to OSHA Standard 29 CFR 1910.66, Subpart F - Powered Platforms, Manlifts, and Vehicle-Mounted Work Platforms, ANSI Standard A120.1, Safety Requirements for Powered Platforms for Building Maintenance, and ANSI Standard A39.1, Safety Requirements for Window Cleaning.

**Waste Removal Equipment.** Waste is normally removed from GSA buildings by contract maintenance firms. The firm will usually collect the waste from receptacles in the occupied spaces into carts which will be taken to larger containers at the waste pick-up station. The firm will usually provide the containers as part of its contract.

The minimum architectural requirements for waste removal are: access for waste handling equipment from the occupied areas of the building to the pick-up station; housing for the on-site containers; and maneuvering space for the collection vehicles. In calculating numbers of containers, assume separate containers for recyclable materials (paper, glass and metals). Waste handling stations must be completely screened by walls and doors or gates constructed of materials complementary to that of the building.

Certain buildings may require additional waste handling equipment such as incinerators or compactors. All incinerator designs must be approved by the Environmental Protection Agency. GSA will coordinate this review.

**Toilet Compartments.** All toilet partitions must be ceiling hung. They should be metal or similarly durable construction. Plastic laminate toilet partitions are not permitted.

**Toilet Accessories.** Stainless steel is preferred for toilet accessories. Accessories should be integrated into the design of toilet rooms. Recessed and multi-function accessories that do not clutter the room are preferred.

**Flagpoles.** See Chapter 2: *Site Planning and Landscape Design, Landscape Design, Landscape Elements.*

**Telephone Enclosures.** Enclosures for public telephones should be provided in the main lobby, near the cafeteria, near the auditorium and in other building areas serving the public.

**Drinking Fountains.** At least one water fountain should be provided on every floor near toilet rooms and near auditoria. At least half of all drinking fountains should be accessible to the handicapped.

**Window Blinds.** All GSA buildings should be equipped with adjustable louver blinds.

## **Elevators**

All elevators must be designed to comply with ANSI A17.1. See Chapter 1: *General Requirements, Codes and Standards, Mandatory Design Standards, Elevator Design Standards.*

Lockout should be provided for all floors served by passenger and freight elevators. Key locks, card readers or coded key pads, integral with the elevator control panel, must be provided to override lockout. See Chapter 8: *Security Design, Building Security, Elevators.*



The elevator alarm should annunciate at the monitoring panel of the building security system.

An emergency telephone should be provided in the elevator cab with a telephone junction box provided in the elevator machine room. Phones must have automatic dialing to a local emergency response number, backed up by automatic dialling of GSA Regional Control Center if the first number is busy or disabled.

Provide trap doors and hoists at the elevator machine rooms for traction elevators where the machine room is not served by a freight or service elevator.

Freight elevators should be provided with vertical bi-parting entrances.

## **Interior Landscape**

See Chapter 2: *Site Planning and Landscape Design* for requirements.

## **Artwork and Graphics**

**Artwork.** Most Federal projects include a budget for artwork as part of the Federal Art in Architecture program. The program statement will identify whether art is to be part of the project. Style and media may vary. They include sculpture, bas-relief, mobiles, water sculpture, earthworks, light sculpture, assemblages, murals, photographs, frescoes, large scale crafts, such as ceramics, tapestries and fiberworks or literary or poetic inscriptions. The process of commissioning art in Federal buildings is a collaboration between GSA, the architect, art professionals and community representatives. The architect should make suggestions on the prospective locations for artwork and should integrate the work into the design.

**Graphics and Signage.** Graphics and signs must be clear and simple, and should be standardized to ensure easy identification of the building entrance, parking, and all the tenant agencies and services located in the building. The signage system should be pleasing and comprehensible. Signs combining pictures and printed messages, as shown in Figure 3-23, are recommended, since they are easier to understand for people who do not read English. Sign design should comply with Underwriters Laboratory (UL) - Illuminated Signs Standard; Occupational Safety and Health Administration (OSHA) Standards for safety signs; and Federal Standard 795 for signs indicating accessibility to the handicapped. Signage must be designed to be adjustable for tenant moves and

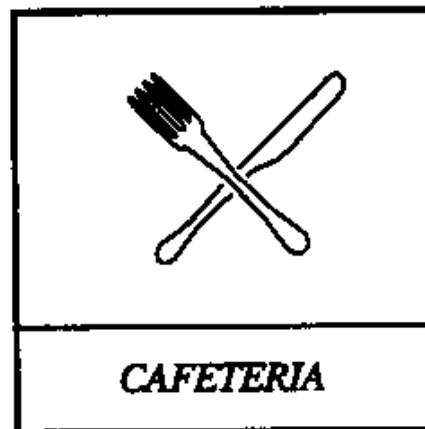
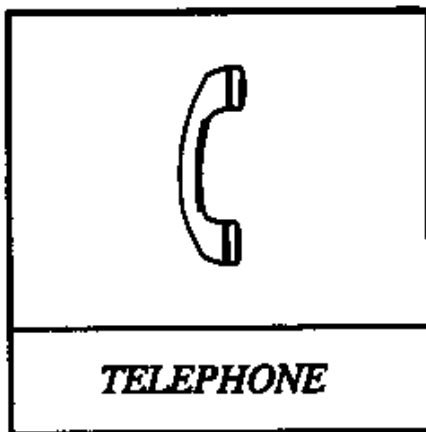

changes. The specifications should ensure that GSA will be provided with the equipment and supplies required to make future signage changes.

Figure 3-23  
**Directional Signage**

## Interior Finishes

Finishes for spaces in Federal buildings should be chosen for quality, durability and cost. They are an important expression of the overall quality of design of the building. If one compares the amount of time an employee or visitor spends inside the building to the amount of time spent outside looking at the exterior, the importance of the quality of the interior design immediately becomes clear.

It is the designer's responsibility to achieve the highest level of quality in interior finishes within the parameters of the project budget designated for that cost element. Flooring, wall and ceiling finishes should combine to give a subtle, lasting impression of high quality.

Materials that release volatile organic compounds should be avoided.

Court buildings, border stations, and child care centers have special requirements for finishes. See the *U.S. Courts Design Guide*, *U.S. Border Station Design Guide (PBS-PQ130)*, and *GSA Child Care Center Design Guide (PBS-PQ140)* for finishes for these facilities.

**Minimum Standards for Finishes in Tenant Spaces.** GSA has set minimum standards for the quality of finishes in tenant spaces, i.e., office space, ADP areas, training and conference rooms and internal corridors. Architects are encouraged to select materials of higher quality, within the budget constraints of the project.

*Carpets.* Carpet tile must be at least commercial grade. The minimum acceptable face weight for level loop and cut pile construction is 880 g/m<sup>2</sup>. The minimum face weight for plush and twist pile construction is 1 085 g/m<sup>2</sup>.

Broadloom carpet must be at least commercial grade. The minimum acceptable face weight is 880 g/m<sup>2</sup> for level loop and multi-level loop construction a 1 085 g/m<sup>2</sup> for level-cut pile construction.

The minimum English system density for all carpets is 4,000 for 100 percent nylon (loop and cut pile) and 4,500 for all other fibers and all blends.

*Vinyl Wall Covering.* The minimum quality of vinyl wall covering is medium grade with a minimum weight of 440 g/m<sup>2</sup>.

**Colors and Textures.** A sensitive color scheme adds to the aesthetic quality of a building and to the well-being of its occupants. Light tones and neutral colors are best suited for the primary palette since one does not tire of them easily. Accent colors add interest and highlight specific areas. Subtle differences in color schemes between departments and floors help establish departmental territories and aid in orientation. In large buildings, tenants should have several coordinated color palettes to choose from.

Colors should be chosen with consideration given to the type of lighting proposed for the space. The amount of wear expected must also be considered, particularly when choosing flooring materials. Dirt and stains are more easily hidden by medium tone color blends than by solid colors.

Textures should be varied and suited to the absorbency, non-slip or cleanliness requirements of the spaces where they occur. Recommended minimum reflectance values are 80 percent for ceilings, 50 percent for walls and 20 percent for floors. Both high-gloss and flat paints are difficult to clean and have to be replaced more often than semi-gloss paints.

#### General Office Space (Open and Enclosed Offices)

This category of space comprises a large proportion of area in Federal buildings. Materials, surfaces, and systems must be chosen with quality and flexibility as primary concerns. Office spaces characteristically change with their occupants, occupancy configurations and utility requirements. Interior finishes should allow these transformations to occur with minimal disturbance and cost.

**Floors.** Carpet is the material of choice for Federal offices. Aesthetics, comfort and sound control are best provided by carpet. Carpet tile is preferable to broadloom carpeting in many instances because it can be replaced more easily. Resilient flooring should only be used in offices adjacent to utilitarian spaces such as loading docks.

**Carpet for Raised Access Floor.** Carpet tiles must be used on raised access floor. Both carpet adhered to floor panels and loose-laid carpet tile are permitted. Generally, the best appearance is achieved when carpet tile is loose laid and overlaps the joints in the access flooring.

**Walls.** Conventional drywall partition systems are appropriate for most applications in general office space. Avoid the use of demountable partitions because they are not justified by their cost. Partial height or full height systems furniture is appropriate for open plan office configurations.

Partition finishes within a tenant space should be limited to paint or vinyl wall covering.

**Ceilings.** Suspended acoustical materials should be selected for all general office space. Grid size and spacing should be based on the building planning module. Avoid inaccessible ceiling systems.

*Standard Ceiling Tile.* It is desirable to standardize acoustic ceiling tile within the building as much as possible to minimize the amount of replacement stock. The recommended standard ceiling tile is a commercial quality, 600 mm by 600 mm tile. See the section *Building Planning, Planning Module* in this chapter.

**Doors.** The finish for solid core wood doors in general office spaces should be limited to wood veneer. Glass doors may be used at entrances to tenant suites.

#### Automated Data Processing Areas

These areas should be finished with surfaces similar to adjacent general office areas. Raised access flooring, typical of these areas, should be finished with carpet tile.

#### Training and Conference Rooms

These areas should be finished at levels of quality equivalent to the adjacent office areas. In addition, the application of tackable acoustic wall panels and rails for the display of presentation materials within these spaces is appropriate.

### Internal Corridors

Corridors within general office areas should receive the same finishes as the office areas themselves. Color changes may be useful in these areas for orientation.

### Public Spaces

#### Entrances and Vestibules

It is desirable to integrate the exterior and interior building design in these areas. Materials should relate and be of high quality. Choose durable, moisture-resistant materials since these areas are typically exposed to weather.

**Floors.** All entrance areas require a mat to prevent dirt and moisture from accumulating on the entrance lobby floor. Buildings located in areas with severe weather conditions will require more elaborate entry mat and drainage systems to prevent the tracking of melting snow and rain. Buildings located in more moderate climates may require only a natural or synthetic fiber floor mat. The entrance vestibule may also have a hard surface flooring surrounding the matted area that would be part of the adjoining main entrance area.

**Walls.** Wall surfaces should relate directly to the predominant materials of lobbies and other public areas beyond. This might be accomplished by glazed walls, which allow direct viewing of the areas beyond, or by extending the use of the lobby materials into the entrance and vestibule.

**Doors.** Doors at building entrances and vestibules should be glazed to facilitate orientation and safe movement in these high traffic areas.

### Entrance Lobbies and Atria

Entrance lobbies and atria are the focal point of the Federal building. They are the landmark to which all other spaces in the facility relate. They should be an extension of the exterior of the building and the point of transition to interior spaces. These spaces have high levels of visibility and public use and warrant the highest degree of visual detail and finish. Since lobbies are subject to heavy traffic, materials and surfaces should age well.

**Flooring.** Hard surface materials, such as stone, brick, or tile, are appropriate for these areas. Except for seating areas, avoid the use of carpet. Safety is also an important consideration. In areas near entrances, materials with non-slip characteristics should be selected.

**Walls.** Wall treatments in lobbies are to be chosen for durability and visual quality. The intensive use and importance of the spaces justify high quality materials. Although paint is permissible its use should be very limited.

**Ceiling Systems.** Higher quality ceiling materials should be selected. Whatever the material, ceilings should be accessible. Coves of gypsum board or plaster may be used in conjunction with acoustical ceilings.

### Elevator and Escalator Lobbies

These lobbies are functionally related to the public entrance and lobby areas and, therefore, should be treated with the same high finish levels as those spaces. It is appropriate to introduce special floor, wall and ceiling treatments and special lighting that can be repeated on the upper floors for continuity.

**Floors.** Elevator and escalator lobbies should harmonize with the finishes used in the entrance lobby or atrium. Because of their importance in orientation and movement, floor treatments in these areas should be similar throughout the building.

**Walls.** Use durable, high quality surfaces, and coordinate wall finishes with elevator door and frame finishes.

**Ceilings.** Special treatments are appropriate to visually distinguish elevator lobbies. Avoid completely sealed systems as they make access to elements above the ceiling difficult.

### Elevators

Passenger elevators usually receive the highest amount of traffic in the facility. Their finishes should relate to the entrance and lobby areas and should be focal points for the interior design of the building. Although finishes need to be durable, high quality architectural design of cabs and entrances is a priority.

**Floors.** Elevator floors receive a great amount of wear in a very concentrated area. The flooring surface should be either extremely durable or easily replaceable. Hard surface floors, such as stone, brick or tile, are usually poor choices because cab floors tend to be unstable. Over time, grouted materials often loosen or crack. Carpet, wood or high quality resilient materials are better choices and perform well acoustically. Carpet materials should be selected for low pile height and high density. Service or freight elevators should have floors of resilient sheet vinyl or vinyl tile.



**Walls.** Wall materials should present a high quality image and should be sufficiently durable to take some abuse. Materials should be installed on removable panels or other replaceable devices to facilitate maintenance and renewal of finishes.

**Ceilings.** Ceilings should be replaceable. In passenger elevators recessed downlights or indirect fixtures should be used.

**Doors.** Surfaces should be scratch resistant and easily replaced or refinished. Inside and outside finishes should be coordinated with adjacent wall surfaces.

**Freight Elevators.** Finishes for freight elevators should be very durable and easy to clean. Stainless steel walls and doors are preferred. Flooring should be sheet vinyl or resilient vinyl tile. Ceiling light fixtures must be recessed and protected from possible damage.

Stairways (closed)

**General Requirements.** Where internal stairways are used for both general vertical circulation and emergency egress, finishes should be consistent with the floors being served by the stair. Since stairs tend to be reverberant, avoid the use of predominantly hard surfaces.

In stairways used for utility purposes or only for emergency egress, unfinished or minimally finished surfaces are appropriate.

**Floors.** In general circulation stairs, flooring for stairways, treads, and landings must provide acoustic control. Carpet and resilient materials are most appropriate and should be combined with a non-slip nosing on the treads. These surfaces should be coordinated with materials of the floors which the stair serves. Utility and egress-only stairs should be of unfinished, sealed concrete or steel. Always provide non-slip nosings.

**Walls.** Wall surfaces in these areas should be drywall substrate with a simple, straightforward finish such as paint or wall covering. Highly finished or heavily textured finishes may be used where a design statement is appropriate. In utility and egress stairs, provide a painted or unfinished surface.

**Ceilings.** Absorptive materials are desirable in stairways for their acoustic effect. Stair runs should have painted gypsum board soffits.

**Doors.** Doors between adjacent building areas and stairways should match other doors in the building areas. The doors should have the same finish on the interior and the exterior. Utility and egress stair doors should be painted metal.

#### Stairways (open)

Open stairways that connect lobby and atrium spaces should be appropriately finished in materials that match or relate to the adjacent surfaces in quality and appearance.

**Floors.** Floor finishes for open stairs should match or coordinate with the adjoining lobby and atrium spaces served by these stairs.

#### Public Corridors

Emphasis should be toward brightness of corridor spaces. Colors and textures should be selected for their ability to visually open and widen these areas.

Provide shifts, portals, or changes in materials and lighting in corridors that are excessively long to add visual interest. Avoid surface treatments that accentuate the linear nature of corridors.

Where permitted, the use of glazing in corridors is appropriate to visually enlarge the space.

**Floors.** To improve acoustic control in corridors, hard, reflective surfaces should be avoided. However, if the corridors occur as extensions of lobbies or other areas with hard surface flooring, it is appropriate to continue that material into the corridors.

**Walls.** Walls in public corridors should receive a wall covering over a drywall substrate.

**Ceilings.** Accessible acoustical ceilings should be selected for corridors. Use a high quality system in public areas. Avoid inaccessible (sealed) ceiling systems.

**Doors.** Doors along public corridors should be of a quality equivalent to that of other elements in these spaces and higher quality than those in the interior spaces. Finish may be wood veneer. The finish on both sides of the door should match. At interior spaces with high levels of public use provide glazed entry door systems along public corridors.

#### Pedestrian Tunnels and Bridges

These areas will generally follow the same criteria as public corridors. Because they tend to be longer, it is more important that they be bright, visually generous spaces. Where possible, introduce daylight to these spaces through skylights or glazed walls.

**Floors.** Since these spaces are part of the public corridor system, they should be treated similarly. Carpeting similar to that of other public corridors should be continued into these areas. For service passages, sealed concrete or resilient flooring should be used.

**Walls.** The criteria for public corridors are applicable for tunnels and bridges. Glazed openings are preferred.

**Ceilings.** The criteria for public corridors are also applicable for tunnels and bridges.

**Windows.** The glass and frame systems of any glazing should be an extension of the building window system.

## Building Support Spaces

### General Use Toilets

Toilets are part of the permanent building core and should be designed with good quality, long lived finishes. They are an extension of the public spaces of the building. The most appropriate finish for floors and walls in toilet rooms is ceramic tile. In light use areas, less costly moisture-resistant materials may be substituted. In all cases, carefully chosen patterns and colors will enhance the design image.

Continuous vanities of stone, artificial stone, tile or plastic laminate should be designed for lavatories. A large, continuous mirror should be provided on at least one wall of each toilet room. See section *Guidelines for Building Elements, Building Specialties* of this chapter for toilet partitions and accessories.

### Equipment Spaces and Maintenance Shops

Walls and ceilings should be painted in main mechanical, electrical and communications equipment rooms and maintenance shops. Communications equipment rooms should also have resilient flooring. Floors in mechanical rooms and maintenance shops should be waterproofed.

### Staff Locker Rooms and Custodial Spaces

Storage rooms should receive minimal finishes. As in other support areas, these finishes should be coordinated with adjacent spaces. Janitors' closets should be similarly finished, except those containing sinks, which should be provided with a ceramic tile floor and base.

Staff locker rooms should be provided with resilient flooring and vinyl wallcovering (or equivalent), except in "wet" areas, which should be finished similar to general use toilets (ceramic tile floor and walls).

### Building Engineer's Office and Security Control Center

These spaces should be finished like office space.

### Specialty Areas

#### Food Service Areas

**Cafeteria Kitchens and Serveries.** These areas are operated under concession agreements. Finishes are governed by health regulations and the requirements of the concessionaire. Designers should coordinate their work with the GSA handbook *Concession Management Desk Guide PMFC-93*.

**Kitchens Other Than Cafeteria Kitchens.** Flooring should be resilient and walls should have durable, washable finishes. Vinyl wallcovering or ceramic tile may be appropriate, depending on intensity of use. Acoustical material should be used for ceilings. In wet areas acoustic tile should be mylar finished.

### Dining Areas

Graphic designs should be considered. Glass may be used for entrances adjacent to public corridors. Doors in dining areas may be wood and glass. All doors should be glazed in the upper half of the leaf to safeguard against accidents.

#### Child Care Centers

For finishes of child care centers see GSA *Child Care Center Design Guide (PBS-PQ140)*, Chapter 9: Interior Finishes.

## **Space Planning for Open Office Space**

Most of the buildings owned or managed by GSA are office buildings and at least partially use an open plan layout. The success of open plan design depends on a good floorplan, acoustics, views, daylight and well designed systems furniture.

### **Space Layouts.**

Good open plans allow for ample circulation and open space between groups of work stations. Work stations within the occupiable space of GSA buildings average 14 m<sup>2</sup> per person. The actual work station (excluding conference rooms and equipment rooms) may be as low as 3.7 m<sup>2</sup> per person.

Grouping work stations around open, informal meeting areas can increase communication between workers. Glazed partitions fronting the open area add to a feeling of spaciousness and should be used extensively where appropriate.

In laying out work stations, care should be taken to avoid long rows of cubicles. The planning grid described in section Building Planning, Planning Module of this chapter can be adapted to function with layouts that are rotated or even curved. At a minimum, grids can be set at 90 degree angles with each other with small open spaces in between.

Where glazed partitions are used between work stations, desks must be oriented so that occupants do not face each other directly.

**Views.** Daylight and views for everyone were the big selling points when open plans were introduced. Even with large windows, however, daylight does not penetrate far into the building interior. Research indicates that people respond more to views of the outside world than to daylight. The ability to look up from detail work and focus on the far distance lessens fatigue and eye strain. People also feel better when they can keep track of the weather and activity outside their enclosed environment. Windows should be large, both tall and wide. Sill height should be between 400 mm and 760 mm.

The common practice of locating private offices of supervisors on the exterior of an open plan office should be avoided. Instead they should be placed around the building core and should have partially glazed walls looking out on the open plan space and the windows beyond. Private corporations have reported that this arrangement increases informal interaction between supervisors and staff.

**Acoustics.** Noise distraction and lack of speech privacy are the biggest potential drawbacks of open office planning.

The ambient noise level can be reduced significantly by specifying sound absorbent floor and ceiling finishes and using systems furniture with NIC ratings of 20 or higher.

See the section *Special Design Considerations, Acoustics, Design Criteria for Building Spaces, Class C2 Spaces* of this chapter. Noisy equipment, such as copiers, should be isolated from the general work space.

There are two methods of providing speech privacy in an open plan: distance between work stations and background sound masking. With systems furniture partitions, distances between desks of 3 000 mm or more give reasonable results; unfortunately there is often insufficient floor area to maintain this much separation.

This does not mean that background sound masking should be specified for every open plan office. The actual need for speech privacy varies widely between different groups of occupants; often group privacy is more important than individual privacy. Many people are used to the voices of their co-workers and the noise level within their group but are disturbed by noise from adjacent groups. Groups of work stations should be oriented differently to allow this sense of territory to develop.

**Systems Furniture.** Where floor distribution systems are available for power and data outlets, systems furniture should NOT be electrified. Pre-wired furniture is considerably more difficult and expensive to relocate; it should only be used in buildings where no other delivery of power and computer networks is possible. See the section *Planning Module, Floor-to-Floor Heights and Vertical Building Zoning* of this chapter. See also Chapter 6: *Electrical Engineering, Wiring Devices, Placement of Receptacles, Office Space*.

## **Alterations in Existing Buildings and Historic Structures**

The general goal of alteration projects is to meet the facilities standards described in this book for new projects. Renovation designs must satisfy the immediate occupancy needs and anticipate additional future changes. As they are remodeled, building systems should become more flexible and adaptable to changing occupancy needs.

Alteration projects are defined at three basic scales: refurbishment of an area within a building, such as a floor or a suite; major renovation of an entire structure; and upgrade/restoration of historic structures.

In the first instance, the aim should be to satisfy the program requirements within the parameters and constraints of the existing systems. The smaller the area in comparison to the overall building, the fewer changes to existing systems should be attempted. Components, equipment and construction should match the existing as much as possible to facilitate building maintenance.

In the second case, the opportunity exists to approximate the standards and flexibility of a new building, within the limits of the existing space and structural capacity.

Where a historic structure is to be altered, special documents will be provided by GSA to help guide the design of the alterations. The most important of these is the Historic Building Preservation Plan (HBPP) which identifies zones of architectural importance, specific character-defining elements that should be preserved, and standards to be employed. See Chapter 1: *General Requirements, Applicability of the Facilities Standards, Types of Facilities, Historic Buildings*.

To the extent feasible, GSA seeks to achieve the rehabilitation of historic structures. Rehabilitation is defined as the act or process of making possible a compatible use for a property through repair, alterations, and additions while preserving those portions or features which convey its historical, cultural, or architectural values.



The architectural, mechanical and electrical systems in historic buildings often differ greatly from today's design and construction standards, and frequently many of these building systems need to be upgraded substantially or completely rebuilt or replaced. The end result should be a building whose architectural, mechanical and electrical systems support its modern use while retaining its historic and architectural character.

Understanding the exact requirements of the user is essential to effectively implement the program for remodel projects. Close interaction between designers and users during the programming and concept design phase will enable the designers to meet the users' needs without incurring excessive construction cost. Practical solutions often develop in a dialogue with the users that would not have been relayed by an administrator.

Alteration design requires ingenuity and imagination. It is inherently unsuited to rigid sets of rules. Each case is unique. The paragraphs that follow should be viewed as guidelines and helpful hints to be used when appropriate and disregarded when not.

### **Evaluation of Existing Systems**

Every alteration project includes an evaluation which describes the physical condition of building systems, identifies variances from present codes, and notes available capacity for structural, mechanical, electrical and communications systems.

### **Code Requirements for Alterations**

For most major renovations an evaluation of code deficiencies is appropriate. See Chapter 1: *General Requirements, Codes and Standards, Building Codes*. Code deficiencies that relate to life safety, particularly egress, should be remedied. Strict adherence to the letter of the code is often impossible. Equivalent methods will have to be found to achieve the same life safety goals. Architects will be expected to work closely with the designated GSA code reviewer who will have final authority on code compliance issues.

New work in alterations generally should meet current codes, unless a special hazard is created by combining new and old systems. Such conflicts should be resolved with GSA.

See Chapter 7: *Fire Protection Engineering, Alterations in Existing Buildings and Historic Structures*.

## **Placing Mechanical and Electrical Systems in Renovated and Rehabilitated Buildings**

Finding space for air conditioning, power and communications cabling is one of the biggest design challenges in remodeling work. Existing systems are usually totally inadequate, shafts are too small and ceiling space is too shallow. See Chapter 5: *Mechanical Engineering, Major Alterations in Existing Buildings and Historic Structures* and Chapter 6: *Electrical Engineering, Major Alterations in Existing Buildings and Historic Structures*.

**Vertical Distribution.** Space for new shafts can sometimes be found in stairwells, if the stairs are larger than required by code. If elevator systems need to be replaced, elevator shafts can become duct shafts or electrical closets. The building exterior also offers possibilities if new vertical elements can be integrated with the façade design.

**Horizontal Distribution.** Fortunately, many older buildings have tall floor to floor heights, which give the architect two options: a raised access floor or a very deep ceiling space.

Raised access flooring is an attractive choice for buildings that are being completely remodeled. Raised flooring can be lower than the minimum of 200 mm indicated for new buildings if floor-to-floor height is insufficient. It offers the same systems quality and flexibility as a new building.

The other option is to create a deep ceiling space and zone it carefully for the most efficient fit of all engineering systems. See section *Building Planning, Planning Module, Floor-to-Floor Heights and Vertical Building Zoning* of this chapter for zoning of ceiling space. Ceilings should never be dropped below the level of the window head. In historic buildings, care should be taken not to allow the installation of dropped ceilings to damage character-defining architectural details and, if possible, to maintain visual access to such details.

In narrow buildings, it may be possible to create a furred horizontal space adjacent to the exterior and core walls, which can be used as a raceway for utilities. Vertical furring on columns and walls for receptacles is another possibility and can be

*CHAPTER 3. ARCHITECTURAL AND INTERIOR DESIGN*

---

integrated as an architectural feature. If space is tight, all-water or water-and-air systems should be considered for air conditioning, instead of all-air systems.

Utility distribution in historic buildings is the most difficult because ceilings and floors often have to be preserved or restored. In these cases, decentralized air conditioning units with little or no ductwork become feasible. Pre-wired systems furniture, which is available in wood, is also a very good solution.

**Placement of Main Mechanical and Electrical Equipment.** If new equipment is to be placed on the roof, the structural capacity of the framing system must be investigated.

Elevators. For complete building renovations a transportation study should be done, as described earlier in this chapter. If elevators need to be replaced, service can often be improved significantly by selecting higher speed elevators to fit into the existing shafts. New shafts are expensive to build and should be avoided.

### **Space Planning Strategies**

**Office Space.** It may be necessary to design a slightly larger space allocation - about 12 m<sup>2</sup> per person - for office layouts in older buildings. This compensates for less than ideal bay sizes and existing walls configurations.

The planning standards described earlier in the section *Space Planning, Office Space, Closed Offices Versus Open Plan* and *Space Planning for Open Office Space, Space Layouts* should be used as much as possible.

Pre-wired systems furniture may be an appropriate solution for distribution of power and communications wiring in renovated buildings.

Open plans have been used successfully in historic buildings. Furniture systems must be selected with great care to minimize any adverse impact on the historic features of the building.

**Food Service.** In many older Federal buildings, dining areas are located below grade in cramped, poorly ventilated and poorly lit spaces. Major renovations are a good opportunity to correct this situation. Cost considerations may prohibit moving the kitchen, but light and air can be brought into dining areas by excavating and then glazing to provide views of sunken courtyards outside the dining room.

## Acoustics

**Office Space.** Where existing office space is altered to an open plan, noise isolation of the ceiling system should be a minimum of NIC 20. Noise isolation class between rooms should be NIC 40 in Class B spaces and NIC 35 in Class C space. See the section *Special Design Considerations, Acoustics, Design Criteria for Building Spaces* of this chapter.

**Historic Buildings.** Hard surfaces often predominate in old buildings and create resonances and echoes. While it may be possible to upgrade the acoustical environment, this should not be done at the expense of the historically valuable features of the building.

## Alteration of Building Elements

**Exterior Closure.** See Chapter 4: *Structural Engineering, Alterations in Existing Buildings*. Most older buildings lack adequate insulation and vapor barriers, but these can be added from the inside at the time of alteration.

In most climates, single-glazed windows should be replaced. Custom profiles are available from many manufacturers to duplicate older styles. In some instances, wood frames and sashes have been restored successfully in place by injecting old wood with an epoxy preparation. With this method, interior finishes are protected from the weather during construction.

Exterior masonry should be cleaned if necessary and repointed. Joints should be resealed.

**Re-roofing.** Where existing roofing is to be replaced, it should be completely removed and the substrate prepared for new roofing. The new roofing should not be of greater weight than the old, unless structural analysis shows that the framing system can carry the additional weight.

### **Uncommon Products Used In Rehabilitations**

In historic preservation it may be necessary to specify uncommon materials that may be hard to find. These products may be described with the supplier's name and address in the specifications. If more than one supplier exists, all names must be stated. The specifications should also contain a note stating: "The use of a trade name in the specifications is to indicate a possible source of the product. The same type of product from other sources shall not be excluded provided it possesses like physical characteristics, color and texture."

# **CHAPTER 4**

# **STRUCTURAL ENGINEERING**

**(Includes Seismic Design)**

## **General Approach**

Three characteristics usually distinguish GSA buildings from buildings built for the private sector: longer life span, changing occupancies, and the use of a life cycle cost approach to determine overall project cost.

GSA generally owns and operates its buildings much longer than private sector owners. Accordingly, a higher level of durability and serviceability is required for all systems. In terms of structural design, this has resulted in more stringent requirements than those stipulated in model building codes; the floor load capacity requirement of this chapter is an example.

***FACILITIES STANDARDS FOR THE PUBLIC BUILDINGS SERVICE***

---

During the life span of a typical Federal building, many minor and major alterations are necessary as the missions of Government agencies and departments change. The capability to accommodate alterations must be incorporated into the building from the outset. In some cases structural systems should be designed to provide some leeway for increase in load concentrations in the future. They should also be designed to facilitate future alterations, e.g., the cutting of openings for new vertical elements, such as piping, conduit and ductwork.



## Codes and Standards

Model codes and mandatory standards adopted by GSA for the design of all new buildings are discussed in Chapter 1: *General Requirements, Codes and Standards, Building Codes*.

### Standards for Structural Design

The standards listed below are recognized industry standards but are not intended to be adopted by this chapter. The user should consult the model building code adopted by GSA. Standards, when specifically referenced in the body of this chapter, are mandatory.

American Concrete Institute: Building Code Requirements for Reinforced Concrete and Commentary (ACI 318 and ACI 318R).

American Concrete Institute: ACI Manual on Concrete Practice.

American Concrete Institute: Building Code Requirements for Masonry Structures (ACI 530) and Appendix A: Special Provisions for Seismic Design and Specifications for Masonry Structures (ACI 530.1).

American Institute of Steel Construction: Manual of Steel Construction.

American Iron & Steel Institute: Cold-formed Steel Design Manual.

American Welding Society: Structural Welding Code AWS D1.1.

American Welding Society: Structural Welding Code, Reinforcing Steel, AWS D1.4.

American Aluminum Manufacturers' Association: Aluminum Handbook.

Steel Deck Institute, Inc.: Design Manual for Composite Decks, Form Decks and Roof Decks.

*FACILITIES STANDARDS FOR THE PUBLIC BUILDINGS SERVICE*

---

Steel Joist Institute: Specifications.

Seismology Committee, Structural Engineers' Association of California:  
Recommended Lateral Force Requirements and Commentary.

Federal Emergency Management Agency (FEMA) publications:

National Earthquake Hazard Reduction Program (NEHRP): Recommended Provisions for the Development of Seismic Regulations for New Buildings, 2 Volumes and Maps (No.'s 222A & 223A).

Guide to Application of the NEHRP Recommended Provisions in Earthquake-Resistant Building Design (No. 140).

Improving Seismic Safety of New Buildings: A Non-technical Explanation (No. 99).

Seismic Considerations, Office Buildings (No. 153).

NEHRP: Handbook of Techniques for the Seismic Rehabilitation of Existing Buildings (No. 172).

NEHRP: Handbook for the Seismic Evaluation of Existing Buildings (No. 178).

Interim Guidelines: Evaluation, Repair, Modification and Design of Welded Moment Frame Structures (No. 267) .

American Institute of Timber Construction: Timber Construction Manual.

National Forest Products Association: National Design Specification for Stress Grade Lumber and Its Fastenings.

American Society of Civil Engineers: Minimum Design Loads for Buildings and Other Structures, ASCE 7-93.

ASME/ANSI A17.1a-1994 Edition, PART 24, Elevator Safety Requirements For Seismic Risk Zone 2 or Greater.

## Dead and Live Loads

GSA promotes flexibility in the use of space. Since corridor locations are not known until after construction begins and are subject to change over time, use the code office corridor live load of 390 kg/m<sup>2</sup> for an entire floor. No additional load contribution from partition dead weight is to be added to this live load. Floors with partitioned office spaces should then have enough capacity to accommodate the code required office load plus the dead load from partitions. Spaces with higher live loads than this should be designed for the code required minimum or the actual live load, whichever is greater. Do not use live load reductions for (1) horizontal framing members, (2) transfer girders supporting columns, and (3) columns or walls supporting the top floor or roof.

Table 4-1  
**Comparison of Seismic Zone and Occupancy Requirements of the UBC  
to the Seismic Performance Category of the NEHRP , BOCA, SBCCI**

ICBO(UBC)		OCCUPANCY TYPE		
		IV	III	II,I
SEISMIC ZONE	Av	SHEG		
		I	II	III
		SPC		
4 & 3	$0.2 < A_v$	D	D	E
2B	$A_v = 0.2$	D	D	E
2B	$0.15 < A_v < 0.20$	C	D	D
2A	$A_v = 0.15$	C	D	D
2A	$0.10 < A_v < 0.15$	C	C	C
1	$A_v = .10$	C	C	C
1	$0.05 < A_v < 0.10$	B	B	C
0	$A_v < 0.05$	A	A	A

## **Building Configuration in Earthquake Zones**

For new building designs in UBC Earthquake Zones 2B, 3 and 4, and for the equivalent NEHRP Seismic Performance Categories (SPC) from Table 4-1, if the following conditions are not met, a static pushover analysis in addition to a dynamic analysis will be made.

**Structural Symmetry.** Buildings should be structurally symmetrical. L-, T-, U-shaped or other asymmetrical plans must be separated by seismic joints into distinct, rectangular structural units.

Large mass elements, such as stairwells and elevator shafts, must be located so that the eccentricity between the center of mass and the center of rigidity of the floor plan does not exceed 15 percent about either orthogonal axis. In Earthquake Zones 3 and 4, stairwells and elevator shafts are not permitted to significantly extend beyond the façade of the building.

**Vertical Structural Uniformity.** Elements that resist lateral loads must be structurally continuous from story-to-story. Continuous load paths, moment frames, columns, shear walls, and braced frames must be identified from the top of the building to the foundation. The load paths should not be interrupted at any story and cannot be relocated in plan at any story.

**Story-to-Story Differentials.** The story-to-story mass differential must not exceed 20 percent, except between a penthouse roof and the main roof. The story-to-story stiffness differential must not exceed 20 percent.

## Structural Systems

### Steel Framing Systems

*Unshored Composite Beams.* Unshored composite steel beams deflect under the weight of concrete slabs at the time of placement. In order to achieve a level floor, additional concrete may need to be poured. Where unshored construction is used, the additional dead load caused by the increased concrete thickness should be accounted for in the structural design and specification.

*Shored Composite Beams.* Shored composite steel beams do not deflect under concrete placement, resulting in less cost of material for concrete and steel. These savings may offset the costs of shoring. Once the shoring is removed, the floor deflects. This type of construction results in a floor that is less level than an unshored system.

*Cambered Composite Beams and Girders.* Cambered composite beams and girders may produce the most level floors. A camber should be considered for beams longer than 7 500 mm. The camber should equal the deflection calculated for the combined dead load of wet concrete, steel deck and steel beams. Superimposed dead and live loads should be excluded from the calculation.

**LRFD versus ASD.** Both Load Resistance Factor Design (LRFD) and Allowable Stress Design (ASD) are acceptable design procedures for GSA buildings; however, for larger building structures LRFD is generally recognized as resulting in more economical steel framing and is preferred by GSA.

## **Concrete Framing Systems**

**Cast-in-Place Systems.** Systems that have fewer limitations in cutting openings during future alterations are preferred over other systems.

**Precast Systems.** Precast floor framing systems should only be used for GSA office buildings when the design can be demonstrated to adapt well to future changes in locations of heavy partitions or equipment. Precast systems may be considered for low-rise structures such as parking garages, industrial buildings, and storage and maintenance facilities. Care must be taken to incorporate the design of vertical-load carrying members with the design of the lateral-load resisting system into one coherent design.

**Pre-tensioning and Post-tensioning.** As with precast floor framing, these should only be used when the design can be demonstrated to not impede future flexibility. Post-tensioning is permitted in beams where code allows its use.

## Stability and Serviceability Criteria

### Progressive Collapse

The structure of the building must not be subject to progressive collapse. The failure of a beam or slab should not result in failure of the structural system below or in adjacent bays.

In case of column failure, the damage should be limited to the bays supported by that column.

### Drift

Lateral deflection of a building under lateral load must be limited to the requirements for wind and earthquake loads. However, satisfying serviceability criteria is also important. Wind-induced motion and sway should be limited, especially with tall or narrow structures.

### Vibration of Floor Systems

Transient vibration induced by passing traffic or footfall should be minimized.

### Corrosion Protection

Structures in salt environments must have a positive means of corrosion protection. Structures requiring protection include concrete foundations exposed to saline groundwater, parking decks, bridges and pavements where de-icing salts are used, and structures exposed to salt-laden air.

**Steel.** Structural steel exposed to the elements must have a protective coating on all steel surfaces. Small, isolated structural steel elements may have hot dipped, galvanized zinc coating or coal tar epoxy paint. Larger exposed steel structures, such as parking, should use a two-coat system consisting of an organic zinc-rich urethane or epoxy primer, shop applied over blast-cleaned surfaces followed by a field-applied finish coat.

**Concrete.** Make provisions for crack control and employ the following methods, alone or in combination, according to the severity of the condition:

- Epoxy-coated reinforcing bars.
- Concrete surface sealers.
- Corrosion-inhibiting concrete additives.
- Microsilica concrete used in lieu of additives.

**Concrete Elements in Parking Structures.** Protect the concrete in parking structures or below building levels by using corrosion-inhibiting additives, epoxy-coated reinforcing bars and a concrete surface sealer. Epoxy-coated reinforcing bars should be used for the top bars of the concrete beam and slab construction and the stirrups of beams and spandrel beams. They should not be used for the bottom bars in beams nor for the reinforcement of columns and walls.

## **Construction Tolerances**

**Concrete Slab Finish Tolerances.** Floor slab finish tolerances should be measured in accordance with ASTM E1155 and should comply with ACI 117: Standard Specification for Tolerances for Concrete Construction and Materials.



## Instrumentation for Buildings in Earthquake Zones 3 and 4

**Instrumentation.** When required by the building program, provide seismic instrumentation to measure horizontal and vertical motions of certain floors relative to the ground. Uniaxial and triaxial accelerographs or equivalent instrumentation should be deployed.

Instruments should be located at the foundation level, at the top floor or the highest permissible building elevation where they can be maintained, and at elevations where there are significant or abrupt changes in structural stiffness, structural mass or structural geometry. Examples are the terminations of perimeter columns and changes in floor plan geometry. Instruments should also be placed at elevations where maximum displacement associated with individual mode shape is anticipated.

When required for a base isolation system, instruments should be provided immediately above and below the plane of isolation.

**Base Isolation.** Base isolation should be considered in Earthquake Zones 3 and 4 for 2- to 12-story buildings, particularly on rock and firm soil sites which are stable under strong earthquake ground motion. The system must be shown to be as cost effective as a conventional foundation system, including the impact on framing and mechanical and electrical systems in the building.

## **Foundation Considerations**

### **Geotechnical Considerations**

The requirements for the geotechnical engineering investigation and report are listed in *GSA Submission Requirements for Design and Construction (PBS-PQ280)*.

### **Protection of Adjoining Property**

Protective measures, including those required by local code, must be taken to avoid the effect of the structure on adjoining buildings both during and after construction.

**Sheeting, Shoring and Underpinning.** Any required sheeting, shoring and underpinning protecting the banks of the excavation or adjoining buildings must be made the full responsibility of the construction contractor.

**Footings Outside Property Lines.** Footings should not project beyond property lines.

## **Attachment of Nonstructural Elements**

All nonstructural elements, components and equipment located within a building or on the site must be anchored to withstand gravity, wind and seismic loads.

### **Exterior Cladding**

Exterior cladding must have connections and joints that permit relative movement between stories. Connections should have sufficient ductility and rotation capacity to preclude the possibility of brittle failure in connection welds or fracture in concrete. Inserts in concrete should be attached to or hooked around reinforcing steel.

Slotted or oversized holes at cladding connections should be used to permit movement parallel to the plane of the building skin.

Window frames should be positively anchored to resist lateral loads. Clearance and flexible mountings should be provided to permit thermal movement and minimize glass breakage in storms and earthquakes.

### **Partitions**

Nonstructural, rigid partitions must be supported by the structure in such a way that they cannot inadvertently become load-carrying elements.

Masonry walls should be isolated from the structure of the floor above by a gap, and be restrained by continuous or intermittent steel angles at the top of the wall on both sides or by steel straps extending into the grout of the wall. Masonry walls should be isolated from concrete columns by flexible joints.

Metal or wood stud partitions do not require in-plane lateral isolation from the structure as long as the design story drift ratio multiplied by  $3(R_w/8)$  is less than 0.0025. In full-height walls, the top of a steel stud should be separated from the track to allow for vertical deflection of the slab.

Partitions less than ceiling height must be braced to the floor to prevent overturning in Earthquake Zones 2 and higher.

Building expansion or seismic joints must be carried through crossing partitions.

## **Ceiling Systems**

**Suspended Grid Systems.** Ceiling suspension systems must support light fixtures that are not supported independently. Suspended ceilings, including air diffusers, light fixtures and speakers, must be braced in accordance with the provisions of the seismic code used. Suspended ceilings must be isolated from walls which extend above the ceiling to the building structure.

**Monolithic Ceilings.** Gypsum board ceilings should be fastened with large head nails or screws. Building expansion or seismic joints must be carried through all monolithic ceilings.

## **Raised Flooring ( Access Flooring)**

Raised floor systems should be specified for gravity loads as described in Chapter 3: *Architectural and Interior Design, Guidelines for Building Elements, Interior Construction, Access Flooring*. In Earthquake Zones 2 and higher, lateral load design must comply with the forces in the Nonstructural Components section of the seismic code used. The superimposed equipment load used in calculations must not be less than  $195 \text{ kg/m}^2$ .

## Furnishings and Equipment

**Fixed Casework and Equipment.** Fixed casework and built-in equipment, such as storage racks and built-in bookcases 500 mm or more in height, should be anchored to floor and walls. For lateral loads due to earthquake, the provisions of the seismic code used should be followed. Where cabinets or shelving are hung from walls, their weight must be included in the partition design.

## Mechanical and Electrical Equipment

**Equipment Anchorage.** Mechanical, electrical and plumbing equipment listed below should be anchored to prevent overturning or sliding due to lateral forces. For lateral loads due to wind or earthquake, the provisions of the national code used should be followed.

Air-handling Units  
Battery racks  
Boilers  
Chillers  
Control Panels  
Cooling Towers  
Emergency Generators  
Heat Exchangers

Motors  
Panelboards  
Pumps  
Tanks  
Switchgear  
Transformers  
Uninterruptible Power Supplies  
Vessels

**Equipment Placed on Vibration Isolation Devices.** In Earthquake Zones 2 and higher, vibration isolators with built-in seismic restraints should be used. Where this is not feasible, seismic bumpers must be designed to restrain the equipment. If bumpers are used, the gap between bumper and the equipment should be as small as possible. Unless a

$$F_p = 5 Z I_p C_p W_p$$

rigorous analysis, done at the option of the equipment manufacturer, indicates a lesser force to be appropriate, bumpers should be designed to resist a minimum force:

Where

- $Z$  = Zone Factor
- $I_p$  = Importance Factor (1.0, unless specified otherwise by GSA)
- $C_p$  = Value for rigid equipment
- $W_p$  = Weight of equipment

**Compressed Gas Cylinders.** Gas cylinders should be anchored or restrained by straps, bars or chains at both top and bottom. For seismic design, the provisions of the national code used should be followed.

**Batteries.** Batteries should be strapped or otherwise anchored to racks.

## **Piping, Conduit and Ductwork**

**Piping (Including Electrical Conduit) and Ductwork.** Supports for piping and ductwork must be designed according to the provisions of applicable codes. In addition, the provisions of the SMACNA: Seismic Restraint Manual: Guidelines for Mechanical Systems should be followed.

**Piping for Fire Protection.** Bracing of piping for sprinkler systems may be in accordance with NFPA: Standard No. 13: Installation of Sprinkler Systems in Earthquake Zone 2 and for the equivalent NEHRP seismic performance category when  $A_v < 0.20$ .

## Alterations in Existing Buildings and Historic Structures

Alteration requires ingenuity and imagination. It is inherently unsuited to rigid sets of rules. Each case is unique. It is recognized that total compliance with standards may not be possible in every case. Where serious difficulties arise, creative solutions that achieve the intent of the standard are encouraged.

Where a historic structure is to be altered, special documents will be provided by GSA to help guide the design of the alterations. The most important of these is the Historic Building Preservation Plan (HBPP) which identifies zones of architectural importance, specific character-defining elements that should be preserved, and standards to be employed. See Chapter 1: *General Requirements, Applicability of the Facilities Standards, Types of Facilities, Historic Buildings.*

### General Design Considerations for Structural Upgrading

**Gravity Loads and Wind Loads.** If GSA has made the determination to upgrade the structural capacity of the building for gravity loads, wind loads or both, the structure must meet the loads required for new buildings. Positive load paths must be documented.

For historic structures, GSA may accept the existing construction and institute operational controls to limit actual live loads.

**Seismic Performance.** If GSA has identified a building for seismic upgrading the following design criteria apply.

The performance objective of a seismic upgrade is life safety, defined as the safeguarding against partial or total building collapse, obstruction of entrance or egress routes and the prevention of falling hazards in a design basis earthquake.

Not all seismic deficiencies warrant remedial action. Seismic upgrading is an expensive and often disruptive process, and it may be more cost effective to accept a marginally deficient building than to enforce full compliance with current code requirements. This concept forms the basis of the standard referenced below.

For each project, alternative methods of seismic strengthening should be studied and feasible schemes developed for cost benefit analysis. The most basic scheme would meet the requirements found in ICSSC RP 4 (NISTIR 5382): Standards of Seismic Safety for Existing Federally Owned or Leased Buildings. The minimum force level used for this analysis of the building shall be the force level from FEMA 178.

When design values obtained from the UBC Seismic Map are higher than values obtained from maps using FEMA 178, schemes which would attain an allowable base shear capacity value equivalent to 80 percent of the current code requirement should be considered. The incremental cost to achieve this higher capacity should be judged against its benefit and the likelihood that the two maps will be brought into parity with each other.

The base shear capacity value is defined as the base shear at which the most highly stressed element attains its allowable stress in accordance with the UBC. Post-benchmark buildings defined in ICSSC RP 4 that achieve 80 percent of the allowable base shear capacity value do not require remedial action.

**Upgrade Priorities.** It may not be practical to upgrade an entire structure to current requirements at any one time. Whenever upgrading is only partially done, the first priority should be given to items that represent the greatest life safety risk, such as the lateral force-resisting system, unreinforced masonry bearing walls or both.

**Seismic Upgrades for Historic Buildings.** Historic buildings should meet the same life-safety objective as other buildings. Decisions made to preserve essential historic features should not result in a lesser seismic performance than that required by ICSSC RP 4. See Chapter 1: *General Requirements, Codes and Standards, Mandatory Design Standards, Conflicts with Historic Preservation*.

**Seismic Strengthening Criteria for Nonstructural Elements.** Where deficiencies in the attachment of elements of structures, nonstructural components and equipment pose a life safety risk, they should be prioritized and those elements with the greatest life safety risk strengthened first to meet current code requirements.



# **CHAPTER 5 MECHANICAL ENGINEERING**

## **General Approach**

The purpose of HVAC and plumbing systems in GSA buildings is to provide a safe, clean, comfortable and healthy environment for the occupants. Ideally, the systems should work so well that the building occupants are not aware of them.

There are three characteristics that distinguish GSA buildings from buildings built by private developers: long life span, changing occupancy needs, and the use of a life cycle cost approach to account for total project cost.

GSA owns and operates its buildings much longer than the private sector. Consequently, a high level of durability is required for systems, as is the ability to replace machinery during the life of the building. GSA has a preference for central boilers and chillers with their attendant lower maintenance requirements; however, selection is done on a life cycle cost basis.

During the life span of a typical Federal building, many minor and major alterations are necessary as the missions of Government agencies change. The flexibility to adjust to alterations easily must be designed into the building from the outset. Mechanical systems should provide capacity for increased localized load concentrations in the future, and allow modifications to be made in one area without causing major disruptions in other areas of the facility.

Private developers base their costs on the amortization of the original building shell and standard tenant fit-up. All later requirements are done as an expense to the tenant. GSA, although still charging expense to the tenant, uses a life cycle cost approach to minimize the total cost to the Federal Government, which is both landlord and tenant. The result is that GSA capitalizes a higher proportion of the initial cost than a private developer.

Third, it is GSA's goal to build buildings with space for the latest advances in office technology and communication. This should be extended to anticipate the future evolution of technology as well. Making this concept a reality requires a comprehensive design for architectural and engineering systems. In the interest of building systems integration, the design work of all disciplines must be executed simultaneously with the architectural concept, rather than retrofitting engineering systems into a solidified architectural design.

There are several options available to a designer when selecting systems for a building. Advances in technology make it tempting to pursue the elusive "state of the art" in modern designs. Yet care must be taken to ensure that reliability is not sacrificed for sophistication. To best serve GSA facilities, designers should use proven systems assembled in a straightforward manner.

Mechanical systems should be designed to respond to the local climate and make best use of natural resources. Natural ventilation and minimal heating and/or cooling are options in temperate climates.

A computer-based building automation system (BAS) that monitors and automatically controls lighting, elevators, heating, ventilating and air conditioning is critical to the efficient operation of the modern Federal office building.

*CHAPTER 5. MECHANICAL ENGINEERING*

---

GSA encourages integration of building automation systems generally. Exceptions are the fire alarm and security systems, which should function as stand-alone systems with an interface to the BAS for monitoring purposes only.

## **Codes and Standards**

As stated in Chapter 1: *General Requirements, Codes and Standards, Building Codes*, facilities should generally comply with the requirements of model building codes, including the mechanical codes referenced therein.

### **Mechanical Design Standards**

The standards listed here are intended as guidelines for design. They are mandatory only where referenced as such in the text of the Chapter. The list is not meant to restrict the use of additional guides or standards.

American Society of Heating, Refrigeration and Air Conditioning Engineers: ASHRAE Handbook of Fundamentals and ASHRAE Standards 15, 55, 62, 100.3, 100.5 and 100.6. Note that ASHRAE 90.1 is a mandatory design standard. See Chapter 1: *General Requirements, Mandatory Design Standards*.

American National Standards Association: ANSI Z 223.1, National Fuel Gas Code.

American Society of Mechanical Engineers: ASME Manuals.

National Fire Protection Association (NFPA): Standards 90, 90A, 90B, 92 and 96.

Sheet Metal and Air Conditioning Contractors' National Association, Inc.: Manuals.

Electronic Industries Association/Telecommunications Industry Association (EIA/TIA) Standard 569: Commercial Building Standard for Telecommunication Pathways and Spaces.

## **Placing Mechanical Systems in Buildings**

In order to achieve system flexibility and thorough integration between building architecture and engineering systems, a concept for the distribution of mechanical systems must be established during the architectural schematic design. The locations of vertical and horizontal mechanical elements should be established before the architectural concept is finalized.

**Planning Grid, Floor Grid and Ceiling Grid.** A common planning module is to be used. The relationship of this module to wall placement, ceiling grids and location of mechanical and electrical elements is described in detail in Chapter 3: *Architectural and Interior Design, Building Planning, Planning Module, Floor-to-Floor Heights and Vertical Building Zoning and Space Planning, Office Space, Floor and Ceiling Grids*. Mechanical elements in floors and ceilings - diffusers, air returns and branch sprinkler piping - are given precise locations. For convenience, the sketches are repeated here, but readers are advised to see the sections in Chapter 3 referenced above.

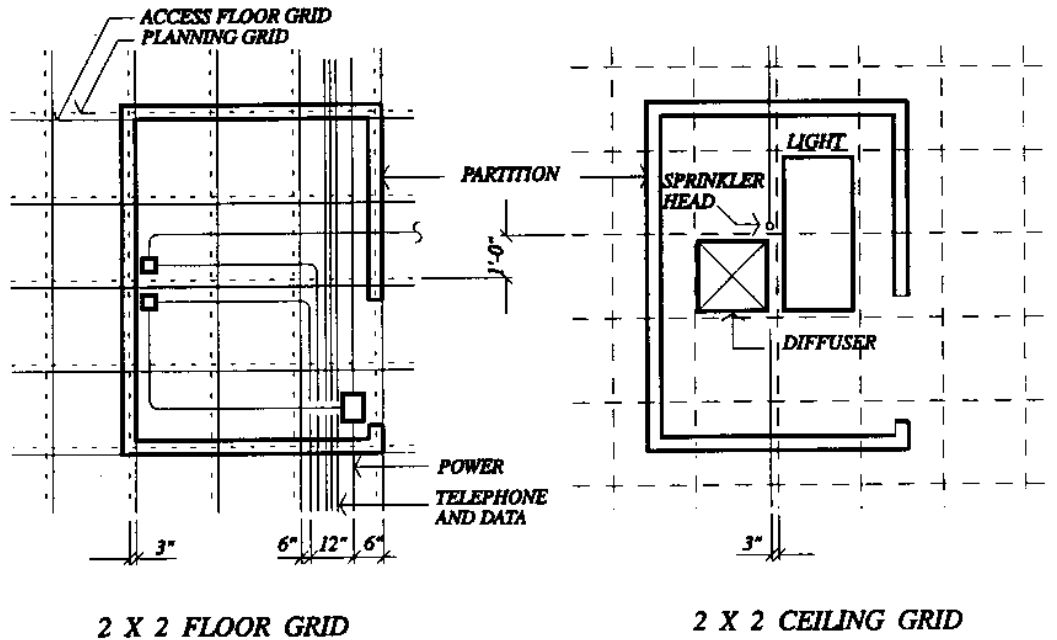

Figure 5-1  
Floor and Ceiling Grid

The centerlines of walls and ceiling height partitions always fall on the planning grid. Underfloor utilities - power, telephone and data - are always 50 percent of the grid line spacing. In all cases where raised access flooring is used, the pedestals of the access floor are offset from the planning grid by 150 mm in both directions.

The ceiling grid is offset from the planning grid in both directions so that the tops of walls never fall on the ceiling grid. This allows for more choices in placing ceiling elements, such as lights and diffusers.

**Horizontal Distribution of HVAC Elements.** Ceiling diffusers would normally be located within the ceiling framing. If slot diffusers are used, as in integrated ceilings, they can be placed on the grid line. Experience has shown that a staggered diffuser layout in a uniform pattern adapts most easily to future changes in wall configurations.

Branch sprinkler piping should always be located 75 mm off the ceiling grid line and sprinkler heads should be placed near the corners of the ceiling tiles.

**Vertical Zoning of Floor-to-Floor Space.** Floor and ceiling spaces must be laid out to provide distinct zones for the placement of different utilities. The floor zone is reserved for power, telephone and data cabling, which are placed in groups of three at certain intervals.

The ceiling space should be layered, with the plumbing and sprinkler piping zone near the underside of the structure, or possibly through it, if steel beams are used, the HVAC duct zone in the middle and the lighting zone immediately above the ceiling level.

The depth of the ceiling and floor space must be determined early in the design, in order to arrive at the floor-to-floor height of the building. It needs to be based on preliminary estimates of systems designs. Enough space must be left between the HVAC and lighting zones to accommodate future lighting moves and changes without moving other components.

The underfloor zone should be as deep as the sum of all the required cross-overs plus tolerances. Bear in mind that raised access floor panels are themselves 50 mm deep. The minimum depth of the total raised access floor, including panels, is 200 mm.

Figure 5-2  
[Reserved]

**Vertical Distribution.** Risers for ducts and hydronic piping should be combined with other core elements to form compact groups and maximize usable floor space. The number and size of risers will depend on the systems chosen, and future flexibility should be an important criterion in the vertical layout as well. Wet columns (domestic cold water, waste and vent) should be placed in each core and distributed in general office space at a maximum distance of 3 600 mm on center. Ductwork and plumbing piping should be run in separate chases.



Water piping must not be placed above ornamental ceilings. If valves for hydronic piping cannot be avoided above inaccessible ceilings, ceiling access panels must be provided at each location. If placed in the exterior wall, it must be located on the inside of insulation and vapor barrier. Extended runs should be avoided in unheated garage space (except in tropical climates).

Gas piping must not be placed in unventilated spaces, such as trenches or unventilated shafts, where leaked gas could accumulate and explode.

**Historic Structures.** Locate pipes so that they do not damage or visually interfere with character-defining elements in historic structures such as windows, doors, columns, beams, arches, baseboards, wainscots, paneling, cornices, ornamental trim, decorative woodwork and other decorative treatments of floors, walls and ceilings.

## **General Design Criteria**

**Energy Conservation.** Energy conservation requirements are detailed in Chapter 1: *General Requirements, Codes and Standards, Mandatory Design Standards, Energy Conservation Standards*. However, energy conservation goals must be realistic. Energy usage must not be set so low that good design practices, such as use of windows or proper ventilation, are compromised.

**Water Conservation.** Although a renewable resource, water is scarce in many parts of the country. Strategies to reduce water consumption - water saving valves for plumbing fixtures, low flush toilets, vacuum waste collection systems and self-closing metered valves - should be evaluated during the design process.

**Visual Impact.** Options for the location and selection of mechanical work that will have a visual impact on the interior and exterior of the building must be closely coordinated with the architectural design. This includes colors and finishes of diffusers, grilles and other exposed mechanical elements, as well as components placed outside the building, such as cooling towers or condensing units.

**Life Cycle Costing.** Chapter 1: *General Requirements, Life Cycle Costing* gives a detailed description of the method to be used for the life cycle cost analysis. It includes parameters specific to Federal buildings, such as future remodeling costs, equipment replacement costs and maintenance costs. Mechanical systems should be selected based on life cycle costing. For smaller and incidental pieces of equipment that do not warrant a full-fledged life cycle cost analysis, alternatives should still be compared taking into account flexibility and maintenance.

Systems that must be selected based on a life cycle cost analysis are the main heating, cooling and air handling systems for each building. At least three options for HVAC systems should be analyzed. Two (or more) options may be of the engineer's choosing, but they must be compared to a base system, which has been established for GSA buildings: a variable air volume system combined with a central cooling and/or heating system. Where the floor size and climate make it feasible, a separate perimeter system (fin tube radiation or separate air system) should be studied as part of the base system.

**Energy Analysis.** The energy analysis is an important predictor of the energy costs of building operations. Several computer programs exist that allow the engineer to simulate several variables applicable to the building design. At a minimum, the chosen program must be capable of accepting the following input parameters: weather data, fuel data, building orientation, building width and length, building mass, number of stories, exterior wall construction, roof construction, glazing in walls and roof, type of glass used and solar screening devices. It should also be able to compare all appropriate mechanical systems options.

Energy consumption goals for lighting and major mechanical systems should be set for the energy analysis.

**Heat Balance Analysis.** This calculation identifies the break-even temperatures of a building for various energy loads and the maximum heating and cooling requirements at outdoor design limits. It is the basis for a design of heat distribution within buildings with heavy thermal loads. Many GSA buildings have sufficient internal heat gain to obviate the need for heating during periods of occupancy if heat transfer can be accomplished within the building. The parameters to use in heat balance calculations include ventilation load, skin loads, light and power load, occupancy load and loads from heat producing equipment.

**Selecting Fuel Sources.** The primary fuel should be selected based on life cycle cost and must be in compliance with local laws. It should be readily available and free of supply restrictions. If interruptible natural gas is shown to be the most favorable fuel, it must be backed up by fuel from another source. Where district heating and/or cooling systems are available, they should be considered, taking into account reliability and potential future expansion needs of the project.

In evaluating fuel costs, actual costs, including demand charges, at the project site should be used, not regional averages.

For each new Federal project, a renewable energy source must be evaluated and compared to conventional fuel sources.

**Sizing Standards for Equipment and Systems.** The sizing of components of mechanical systems is a complicated process of balancing present building loads, reliability and potential future demand. The overriding criterion of any sizing decision is that mechanical systems must operate efficiently at partial and at full load both at the time of building occupancy and many years into the future.

This does not mean that all equipment necessary to satisfy potential future demand must be installed at the time of initial construction. Often it may be more prudent to dedicate space in a mechanical room for future installation of additional equipment. Careful consideration must be given to how the future equipment will tie into existing systems. For example, if space is left for a future chiller, the piping header needs to be sized for the ultimate flow and space needs to be available to add pumps. Another example of future flexibility would be an oversized housing for an air handling unit that would permit the later addition of fans and coils. Finally, electrical service size and expansion potential must be considered.

Reliability is another factor to be considered in sizing equipment. The selection of multiple units of even or uneven size ensures added reliability because either component can carry at least a partial load if one unit breaks down. Multiple units also permit scheduling of equipment running times, e.g., 100 hours for unit 1 then 100 hours for unit 2, which lengthens equipment life.

It is not always necessary to double up equipment to achieve reliability. Often there is a possibility of tying units together that serve different areas of the building under normal conditions. When planning for reliability it is important not to pile redundancy on top of redundancy.

**Operation and Maintenance Considerations.** Generally, Federal buildings are open for operation from 7:00 a.m. until 6:00 p.m. Monday through Friday, except for Federal holidays. In some cases, buildings or parts of buildings may need to operate on 24-hour schedules.

Engineering staff is not usually present in the building after hours. Some GSA buildings are attended by maintenance or security personnel for 24 hours a day, but this is not the norm. Many Federal buildings are supervised from a remote central station at night.

Each GSA building has a Federal manager and core staff. Most of the actual maintenance work is let to private contractors, particularly in the case of larger buildings. Contract maintenance services vary greatly in scope and sophistication, from employment of individuals for specific tasks to full service contracts which include incentive clauses for savings in building operating costs.

Operating conditions will have a large impact on the choice of the building management system and other equipment maintenance considerations. The engineer is, therefore, encouraged to evaluate the planned maintenance provisions for each project.

## **HVAC Design Criteria**

**Outdoor Design Criteria.** Outdoor air design criteria must be based on weather data tabulated in the latest edition of the ASHRAE Handbook of Fundamentals.

Winter design conditions must be based on the 99-percent column dry-bulb temperature in the ASHRAE table. Summer design conditions must be based on the 2.5-percent column dry-bulb temperature with its corresponding mean coincident wet-bulb temperature. Where critical spaces require temperature and humidity to be maintained to close tolerances, cooling loads must be based on the 1-percent column dry-bulb temperature with its corresponding mean coincident wet-bulb temperature.

**Indoor Design Temperatures and Relative Humidity.** Indoor design temperatures and relative humidity are stated in Table 5-1. The office design conditions are set at the middle of the comfort range in the ASHRAE Handbook of Fundamentals. The actual operating conditions may be adjusted for local custom per the Federal Property Management Regulations.

Table 5-1  
Indoor Design Conditions

Type of Area	Summer		Winter	
	DB <sup>1</sup>	RH <sup>2</sup>	DB <sup>1</sup>	RH <sup>2/3</sup>
General Office	24		22	30
ADP Rooms	24	45 <sup>4</sup>	22	40 <sup>4</sup>
Corridors	24		22	
Building Lobbies	24		22	
Toilets, Lockers	24		22	
Electrical Closets	24		22	
Tunnels, Bridges	24		22	
Mech. Spaces	40 <sup>5</sup>		13 <sup>8</sup>	
Elec. Switchgear	33 <sup>5</sup>		13	
Elevator Mach. Room	33 <sup>5</sup>		13	
	40 <sup>6</sup>			
Emerg. Gen. Room				
Transformer Vaults	40 <sup>5</sup>			
Stairwells			18	
Comm./Tel Frame	24		22	30
Room				
Storage Room	24		22	
Conference Room	24		22	30

NOTES:

<sup>1</sup> Temperatures are degrees Celsius, to be maintained at +/-1 C.

<sup>2</sup> Relative humidity is minimum permissible, stated in percent.

<sup>3</sup> Dry-bulb and relative humidity are to be maintained 150 mm to 1 800 mm above the floor.

<sup>4</sup> Relative humidity should be maintained at +/- 5 percent in ADP spaces.

<sup>5</sup> Maximum temperature. Space to be mechanically cooled if necessary.

<sup>6</sup> Room must not exceed temperature with generator running.

<sup>7</sup> Must comply with EIA/TIA Standard 569.

<sup>8</sup> Minimum temperature in the building must be 13 even when unoccupied.

**Outside Air and Ventilation Criteria.** Outside air and total ventilation rates must comply with the latest edition of ASHRAE Standard 62.

The following spaces must be kept under negative pressure relative to surrounding building areas: smoking lounge, toilets, showers, locker rooms, custodial spaces, battery charging rooms and kitchens. The air from these spaces must be exhausted at 100 percent.

**Indoor Air Quality.** Virtually all building materials and furnishings in the internal areas of buildings give off some particulates and/or gases. Common office supplies and equipment have been found to release chemicals, especially duplicators and copiers; even bulk paper has been found to release formaldehyde.

When a building is new, volatile compounds can be released in large quantities from materials, such as adhesives, vinyls and carpets. A purge cycle of 100 percent outside air is recommended to run for several days prior to occupancy.

GSA recognizes the importance of adequate ventilation to maintain indoor air quality. The outside air and ventilation rates of ASHRAE Standard 62 are the minimum acceptable in GSA buildings. Where occupancy requirements are likely to generate high levels of airborne particles, special air filtration should be considered on the return air system.

The location of outside air intakes must be carefully evaluated to avoid short circuiting of building exhaust, contamination by car and truck exhaust fumes or by equipment, such as cooling towers.

## **Internal Heat Gain**

**Occupancy Levels.** The average density of the *occupiable floor area* of a GSA building is one person per 14 square meters. Within areas actually occupied by work stations the occupancy load can be as dense as one person per 7 square meters in local areas. Block loads and room loads should be calculated accordingly. Sensible and latent loads per person should be based on the latest edition the ASHRAE Handbook of Fundamentals.

For dining areas, auditoria and other high occupancy spaces, occupancy loads should represent the number of seats available. Areas not normally occupied, such as storage rooms or mechanical rooms, do not have occupancy loads.



**Lighting Levels.** For preliminary design loads, lighting levels described in Chapter 6: *Electrical Engineering, Lighting, Interior Lighting, Illumination Levels* should be used. They must be consistent with the general building lighting concept, which may consist of overhead lighting, task lighting or both. Assign room loads and return air heat gain accordingly. For special areas such as conference rooms or lobbies where unique or accent lighting may be provided, an additional load should be assumed in the preliminary load calculations.

### **Acoustical Requirements**

Acoustical criteria for all building spaces are described in Chapter 3: *Architectural and Interior Design, Special Design Considerations, Acoustics*. Ambient noise criteria (NC levels), sound transmission class (STC ratings) and speech privacy isolation class (NIC ratings) are provided. Note that mechanical rooms, emergency generator rooms and pump rooms require special sound isolation techniques. See Section *Vibration Isolation, Acoustical Isolation and Seismic Design for Mechanical Spaces* of this chapter.

### **Zoning Criteria for HVAC Systems**

Interior control zones must not exceed 200 square meters per zone for open office areas or a maximum of three offices per zone for closed office areas. Corner offices should be a dedicated zone.

Independent zones should be provided for spaces such as conference rooms, entrance lobbies, atria, kitchen areas, dining areas, child care centers and physical fitness areas.

If a building program shows that an office building will have an open plan layout or if the program does not state a preference, it may be assumed that up to 40 percent of the floor plan will be occupied by closed offices at some point in the future. Zoning should be designed to adapt.

Separate HVAC systems should be designed to serve areas expected to operate on widely differing operating schedules or design conditions. Separate systems are also recommended for buildings where perimeter zones have heating and/or cooling loads very different from interior zones. When a single system serves a large floor, provisions should be made to shut off or set-back the heating and cooling to each area independently.

Large air handling units serving multiple floors are not practical for buildings with scattered loads after normal office hours. Multiple air handlers or floor by floor systems should be considered. Where practical, a cooling/heating loop dedicated to operation after hours should be considered.

Spaces with relatively constant and weather-independent loads should be served with systems separate from those serving perimeter spaces. Areas with special temperature or humidity requirements, such as automated data processing rooms, should be served by separate supplementary or auxiliary systems.

The supply of zone cooling and heating should be sequenced to prevent the simultaneous operation of heating and cooling systems for the same space. Where sequencing is not possible due to ventilation or air circulation requirements, air quantities should be reduced as much as possible before reheating, recooling, or mixing hot and cold air streams. Finally, supply air temperature should be reset to extend economizer operations and to reduce reheating, cooling or mixing.

### **Special HVAC and Plumbing Requirements for Building Spaces**

**Entrance Vestibules.** Sufficient heating and cooling should be provided to offset the infiltration of the space. Where heating degree days are 1 100 0C days per year with base temperature of 18.3 0C or more and wind speed averages more than 7 m/s, air curtains should be considered.

**Mechanical Rooms.** All mechanical rooms must be mechanically ventilated. Water lines should not be located above motor control centers or disconnect switches. Mechanical rooms must have floor drains.

**Kitchens and Dishwashing Areas.** Kitchens with cooking ranges and dishwashers shall be provided with separate exhaust hoods/exhaust systems. Floor drains must be provided.

**Toilet Rooms.** Large toilet rooms with multiple fixtures should have floor drains. Single fixture toilet rooms do not require floor drains.

**Electrical Equipment Rooms.** No water lines are permitted in electrical rooms.

**Communications Closets.** Communications closets must be ventilated and cooled like offices. Communications closets shall meet the requirements of EIA/TIA Standard 569.

**Elevator Machine Rooms.** In climates where heating and/or cooling of the elevator machine room may be required, ventilation louvers should be equipped with motorized dampers (normally open) that close when the heating or cooling system is in operation and that open when the fire alarm is actuated. Cooling or heating must be provided to maintain room conditions required by equipment specifications, normally 900F maximum.

**Emergency Generator Rooms.** Rooms must be ventilated sufficiently to remove heat gain from equipment operation. The air supply and exhaust should be located so air does not short circuit.

Generator exhaust must be carried up to roof level in a flue or exhausted by way of a vault located away from any building wall. Horizontal exhaust through the building wall is not permitted.

**UPS Battery Rooms.** Battery rooms must be equipped with eye wash, emergency showers and floor drains. The exhaust for battery rooms must be connected to the emergency power system. Battery rooms must be exhausted at three air changes per hour minimum.

**Loading Docks.** Outside air intakes must not be located near loading docks.

## **Heating Systems**

### **Steam Heating**

GSA prefers not to generate steam in new buildings or major renovations because of the high operational cost resulting from system maintenance. If steam is furnished to the building, such as under a district heating plan, it should be converted to hot water with a heat exchanger near the entrance into the building.

### **Hot Water Systems**

Normally, water heating systems will be low temperature hot water. This is an efficient, easily controllable system for supplying heat to the perimeter and interior zones of a building. High temperature hot water should be limited to campus distribution systems where heat is supplied from a central plant and should be converted to low temperature water at the entrance to the building.

**Water Treatment.** See section *Cooling Systems, Chilled Water Systems, Water Treatment* of this chapter.

**Temperature and Pressure Drop.** Supply temperatures for forced hot water heating and corresponding temperature drops must correspond to the rated temperature drops on which equipment sizes are based. Total system temperature drop should not exceed 22 C. Design water velocity in piping should not exceed 2.5 m/s per second or design pressure differentials in piping systems should not exceed 4 Pa per meter, whichever is larger. Operating and idle modes of control should be provided.

**Piping.** Series loop piping is permitted only for terminal or branch circuits. Main distribution piping should be a two pipe system, direct or reverse return, or a combination of both. Temperature control and pressure drop at terminal units (including control valves) should be evaluated prior to selection. Reverse return is preferred because it provides the best overall control and reliability. It supplies the same temperature water to each terminal unit - minus negligible line losses - and distributes the proper flow of water in each pipe because all loops are the same length and no short circuiting can occur.

Pressurized diaphragm tanks are preferred over open tanks. Hot water systems must remove accumulated air. Automatic bleed valves should only be used in accessible spaces in mechanical rooms where they can be observed by maintenance personnel. They must be piped directly to open drains. Use manual valves at terminal units and other less accessible high points in the system.

**Freeze Protection.** Propylene glycol should be used to protect hot water systems from freezing, where runs of piping are exposed to weather, where heating operations are intermittent or where coils are exposed to large volumes of outside air. Concentrations of propylene glycol should normally not exceed 30 percent to limit the decrease in heat exchange efficiency. Glycols should not be used directly in boilers, because of corrosion caused by the chemical breakdown of the glycol.

Freeze Protection. Propylene glycol should be used to protect hot water systems from freezing, where runs of piping are exposed to weather, where heating operations are intermittent or where coils are exposed to large volumes of outside air. Concentrations of propylene glycol should normally not exceed 30 percent to limit the decrease in heat exchange efficiency. Glycols should not be used directly in boilers, because of corrosion caused by the chemical breakdown of the glycol.

**Electric Resistance Heat.** Electric resistance heat in coils or baseboards should only be used where it is more cost-effective than other fuels or in cases where alternative heat sources are unavailable.

**Radiant Heat.** Radiant heating systems - electric, hot water or gas fired - may be overhead or underfloor type. They should be considered in lieu of convective or all-air heating systems in areas that experience infiltration loads in excess of two air changes per hour at design heating conditions. Radiant heating systems may also be considered for high bay spaces and loading docks.

## **Boilers and Heat Exchangers**

**Boilers.** Boilers for hydronic hot water applications should generally be low pressure (up to 120 0C). Electric resistance air heating is preferred over electric boilers because it requires less maintenance. Package units, with all components and controls in a pre-assembled unit, are preferred. Controls and relief valves to limit pressure and temperature must be specified separately. Controls are temperature actuated.

Gas valve actuators should not contain NaK (sodium-potassium) elements since these pose a danger to maintenance personnel.

Individual boilers with ratings higher than 29. MW or boiler plants with ratings higher than 73 MW are subject to review by the Environmental Protection Agency. GSA will coordinate this review.

**Heat Exchangers.** Steam-to-water heat exchangers should be used in situations where district steam is supplied and a hot water heating system has been selected. In highrise buildings, it may be an advantage to create zones by distributing steam vertically and installing several heat exchangers, each serving a number of floors.

**Fuel Oil Piping.** Fuel oil piping system should be at least Schedule 40 galvanized steel or black iron. Piping should be able to withstand a test pressure of 2 100 kPa gauge. Fittings should be of the same grade as the pipe. Valves should be bronze, steel or iron and may be screwed, welded, flanged or grooved. Dual wall piping should be used for buried fuel piping. Corrosion protection should be provided if appropriate.

**Underground Fuel Oil Tanks.** Underground fuel oil storage tanks should be of double wall or non-metallic construction or contained in lined vaults to prevent environmental contamination. For underground tanks and piping a leak detection system with monitors and alarms for both is required. The installation must comply with local, State and Federal requirements, as well as EPA 40 CFR 280 and 281.

**Other Tanks and Piping.** Tanks and piping must be compatible with their intended contents.

## Cooling Systems

### Chilled Water Systems

Chilled water systems include chillers, chilled water pumps, piping and cooling towers.

The chilled water temperature differential should be selected to minimize life cycle cost of the system. Larger temperature differentials will reduce pumping and piping costs but may increase coil sizes. Generally, chilled water systems should have a 70C temperature differential, with a design supply water temperature between 40 and 70C. In climates with low relative humidity, an 80C differential may be used.

**Chillers.** Chillers should be specified in accordance with Air-conditioning and Refrigeration Institute (ARI) ratings procedures in ASHRAE/IES 90.1.

Microprocessor-based controls shall be used. They shall have self-diagnostic capability, setpoint displays, run time, and output/input (COP) information.

All chiller systems must consist of multiple machines. Plants with over 1 750 kW each should have at least three machines. Generally, machines should be of equal size and be controlled via the lead-lag control method. No single machine should run for more than 160 consecutive hours.

The number of machines should be selected such that the loss of one in an emergency in peak cooling season will not allow the average space temperature to rise more than 30C over the design temperature assuming that the remaining machines may be run 24 hours a day.

Part load efficiency must be considered in the operating features of the design. Specified efficiencies should be as listed in ARI's application part load value increments to match expected site performance.

**Environmental Protection.** The design of refrigeration machines must comply with Clean Air Act amendment Title VI: Stratospheric Ozone Protection and Code of Federal Regulations (CFR) 40, Part 82: Protection of Stratospheric Ozone.

No chlorofluorocarbon (CFC) refrigerants are permitted in new chillers. Hydrochlorofluorocarbon (HCFC) refrigerants 123 and 22 and hydrofluorocarbon (HFC) refrigerant 134a are acceptable. Other acceptable non-CFC refrigerants are listed in EPA regulations implementing Section 612 (Significant New Alternatives Policy (SNAP)) of the Clean Air Act, Title VI: Stratospheric Ozone Protection.

Refrigeration machines must be equipped with isolation valves, fittings and service apertures as appropriate for refrigerant recovery during servicing and repair, as required by EPA regulations implementing Section 608 of the Clean Air Act, Title VI. Protection systems including low electrical voltage or loss of one phase shall be provided. Chillers must also be easily accessible for internal inspections and cleaning.

Mechanical equipment rooms must be designed in accordance with the requirements of ASHRAE Standard 15, Safety Code for Mechanical Refrigeration.

Chiller leak detection and remote alarming should be connected to the building automation system if installed.

**Light Load or Overtime Requirements.** A small chiller should be considered in climates with light spring and fall loads or where agencies may require night and weekend comfort cooling.

**Chilled Water Pumps.** Pumps should generally be selected to operate at 1750 RPM. Both partial load and full load must fall on the pump curve. The number of primary chilled water pumps should correspond to the number of chillers, and a separate pump should be designed for each condenser water circuit.

**Piping.** Reverse return piping is appropriate for systems with many terminal units of similar pressure drop. Direct-return piping systems should be used where non-uniform pressure drops through equipment must be accommodated. For all systems, proper consideration must be given to location of balancing valves.



**Freeze Protection.** Propylene glycol is used for freeze protection, primarily in low temperature chilled water systems (less than 50C). The concentration of antifreeze should be kept to a practical minimum because of its adverse effect on heat exchange efficiency and pump life. Cooling coil heat transfer de-rating can be about two to three times that of chillers. A 20 percent concentration is adequate for chillers utilizing 30C to 100C water where freeze protection is required to minus 290C outdoor design conditions.

In temperatures of minus 340C or below, the solution may range from 25 percent to 40 percent.

**Condenser Water.** Condenser water circuits must always be recirculating systems. Once-through applications using domestic water are not permitted.

**Water Treatment.** Water available in many parts of the country will cause corrosion and/or scaling in recirculating systems, such as chillers, condensers and hot water systems.

A complete water analysis is essential to the proper design of corrective measures. Since improper addition of chemicals to make-up water is likely to be more harmful than leaving the water untreated, water treatment for all hydronic systems should be designed by a qualified specialist.

**Cooling Towers.** Cooling tower sizes should be based on the 1 percent column of the wet bulb temperature of ASHRAE weather data. Multiple cell towers and isolated basins are required to facilitate operations and maintenance. Piping should be manifolded to allow for any combination of equipment use. Cooling towers should have ladders and platforms for ease of inspections and replacement of components.

Dual speed fans should be considered. Induced draft is preferred since forced draft uses twice the amount of energy and requires multiple fan arrangement towers run continuously to avoid short circuiting. Induced draft towers must have a clear distance equal to the height of the tower on the air intake side(s) to keep air velocity low. Forced draft towers require a clearance of twice the tower width on the intake side(s) to minimize air recirculation. Clean-outs for sediment removal and flushing from basin and piping should be provided.

Cooling towers should be placed on the site so as not to interfere with the appearance of the building. Screen walls and planting may be used to conceal the tower. Cooling towers should also be located to prevent drift or plume fogging on the building or surrounding buildings. If located on the ground they should be kept away from any building wall or parking lot to prevent corrosion of finishes. The effect of start/stop noise and radiated noise on occupied spaces in the vicinity must also be considered. Start/stop noise can be mitigated by specifying A/C inverters.

The foundation tower construction and connections should be designed for a 160 km per hour wind design load. Cooling towers should be constructed of corrosion resistant materials, particularly in coastal areas.

If the cooling tower is located on the building structure, vibration and sound isolation must be provided. Supports should be designed to permit re-roofing under the tower.

Special consideration should be given to deicing cooling towers if they are to operate in sub-freezing weather. A manual shut-down for the fan should be provided. If cooling towers operate intermittently during sub-freezing weather, provisions should be made for draining all piping during periods of shut-down. For this purpose indoor drain down basins are preferred to heated wet basins at the cooling tower.

See Chapter 7: *Fire Protection Engineering, Mechanical Requirements, Special Requirements for Air Conditioning Systems, Cooling Towers* for fire protection provisions for cooling towers.

**Air-Cooled Condensers.** Air-cooled condensers are recommended only for small package systems and in parts of the country where a large daily temperature range exists or where site location limits availability of competent maintenance.

## Special Cooling Applications

**Water-side Economizer Cycle.** In certain climate conditions cooling towers are capable of producing condenser water cold enough to cool the chilled water system without chiller operation. This option should be considered in life cycle cost comparisons of water cooled chillers. Water-side economizer cycles are particularly cost effective in the low humidity climates of the western United States. In the eastern United States, air-side economizer cycles tend to produce lower operating costs. See section *Air Distribution Systems, Air Handling Units, Air-Side Economizer Cycle* of this chapter.

**Computer Room Air-Conditioning Units.** Mainframe computer rooms may be cooled by self-contained units for loads up to 280 kW. These units are specifically designed for this purpose and contain compressors, filters, humidifiers and controls. They should be sized to allow for 50 percent redundancy, either two units at 75 percent load or three units at 50 percent.

For loads above 280 kW, chilled water air handling systems must be used. A group of dedicated chillers is preferred, unless other parts of the building also require 24-hour cooling. It should consist of three chillers, each capable of handling 50 percent of the sensible load. Connections should be available for the future addition of a fourth unit.

Heat rejection should be of recirculating type, such as cooling towers or evaporative condensers. Use of once-through domestic water is prohibited.

For ventilation, air handling and humidification of computer rooms, see section *Air Distribution Systems, Air Handling Units, Computer Room Air Handling* in this chapter.

The room temperature conditions shown in Table 5-1 provide a higher available temperature for reduced fan power consumption and easier winter humidification. See section *HVAC Design Criteria, Indoor Design Temperatures and Relative Humidity* of this chapter. Verify with users to determine if air conditioning system must be connected to emergency power system.

## **Combined Heating and Cooling Systems**

Combined heating and cooling systems all use piping to distribute heating and cooling energy. Ductwork is used for ventilation only. Controls are decentralized and very direct. Depending on climate and building type, they may be more or less energy efficient than all-air systems. Because of the reduction in ductwork they require less ceiling space. Their negative characteristics are higher maintenance requirements than central systems and higher noise levels in the occupied space. It is more difficult to maintain good indoor air quality with these systems because the distribution of fresh air is less controlled and filters are of lower quality than those available for central systems. It is also usually impractical to run economizer cycles with these systems, with the result that mechanical cooling may be required at times when all air systems can run on 100 percent outside air.

### **Heat Pump Systems**

Water source heat pump systems are a design alternative in moderate climates or in thermally heavy buildings in all but the warmest climates.

Heat pumps should not be installed in ceiling space or as through-wall units. Heat pumps should be designed with automatic reset.

The major benefit of this system is its ability to remove surplus heat from one part of the building and use it to heat other parts of the same building. Thus, a heat pump is an inherent heat recovery system.

However, since there are numerous small units throughout the building, maintenance requirements are high. Heat pumps have a shorter life span than central systems. The use of an economizer cycle is usually not practical.

**Unitary Systems (Factory package systems).** Air-cooled rooftop units and water-cooled or air-cooled indoor package units may be advantageous in some instances for a specialized tenant in a multi-tenant building. If current or potential future occupancies indicate a requirement for a number of these units, a central 24-hour chilled water loop is considered preferable.

## Ventilation and Air Distribution

**Pressurization.** In general, a positive pressure should be maintained in a building with respect to the outdoor environment. In areas where exhaust systems are used, a negative pressure should be maintained relative to surrounding spaces by exhausting 5 to 10 percent more air than the supply air to the space.

The ventilation system must be designed to overcome the pressure differentials occurring as a result of large temperature differentials in tall buildings.

### Special Ventilation Requirements

**Toilets.** Fans should be controlled automatically so that they do not operate during unoccupied periods.

**Food Service Areas.** Kitchen areas should be under negative pressure to dining rooms. Make-up air should be introduced at the kitchen hood for up to 50 percent of exhaust air. Duct air velocity should be no less than 7.5 meters per second to hold particulates in suspension. Dish washing areas must be under negative pressure relative to the kitchen.

## **Air Distribution Systems**

### **Constant Volume Systems**

**Single Zone Systems.** Single zone air handlers may be considered for systems with relatively constant loading. Single zone units can be shut down individually without affecting conditions in adjacent spaces.

**Multi-zone and Dual Duct Systems.** Multi-zone and dual duct systems are usually considered for constant volume systems with fluctuations in loading. They should be evaluated with caution as they can be high energy users.

**Multi-zone Systems.** Multi-zone systems often are an appropriate choice for small buildings. They achieve many of the advantages of dual duct systems at a much smaller initial cost. Multi-zone units should be of the three deck type to minimize reheat.

*Reheat.* Reheat permits close control of temperature and moisture levels but it is a high energy consumer. Its use should therefore be limited to laboratories or similar spaces.

**Dual Duct Systems.** Conventional dual duct systems use high reheat and thus are high energy consumers. Where dual duct designs are used, two supply fans, one for the hot deck and one for the cold deck, are recommended. The design should allow all return air to pass through the hot deck where it recovers heat from internal loads for heating. The heating coil should operate only when additional heat is required. Outside air should pass through the cold deck. This configuration limits energy consumption for both heating and cooling, while maintaining excellent temperature and humidity control.

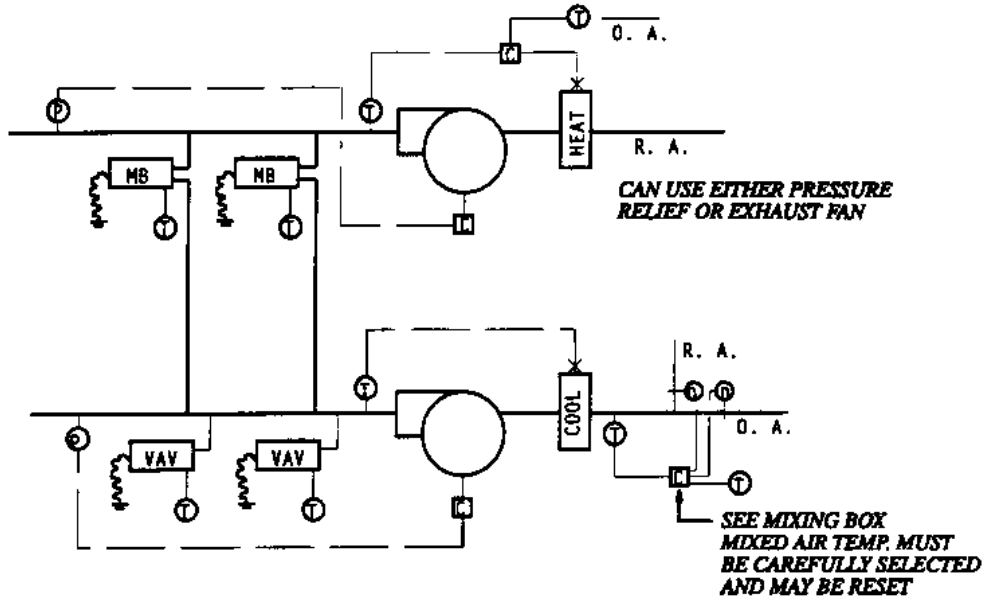
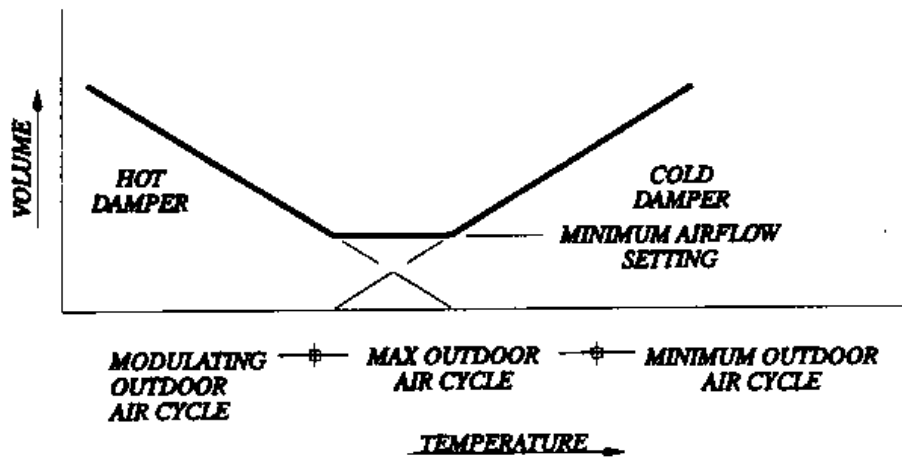

Figure 5-3



Variable Volume System with Separate Perimeter Air System

Figure 5-4

Variable Volume Dual Duct Mixing Box with Minimal Reheat

## **Variable Air Volume (VAV) Systems**

Simple VAV systems provide cooling only. Any heating requirement is handled by a separate perimeter system. The supply fan is designed for the largest block load, not the sum of the individual peaks.

VAV systems offer temperature control for multiple zones and a large degree of flexibility. They are particularly well adapted to subdivisions and rearrangements into new zones as building occupancy needs change. Operating costs are saved by running fans at reduced volume and matching refrigeration and heating to the diversity of loads.

Simple VAV without reheat is generally appropriate for interior zones of office buildings that require year-round cooling.

**Perimeter Zones.** Designers are encouraged to consider the use of an entirely separate perimeter system, which may be central air or water type. Figure 5-3 describes a VAV system that has interior and exterior zones and minimizes reheat.

**Volume Control.** VAV systems depend on volume modulation to achieve the required ventilation and temperature, which makes volume control critical to the successful operation of the system. Room loads must be calculated accurately to avoid excessive throttling of air flow due to oversized fans and terminal units. Diffusers should be high entrainment type (3:1 minimum) to maximize air velocity at low flow rates. Also, the minimum volume setting should equal the larger of the following: a) 30 percent of the peak supply volume; or b) 2 L/s per square meter of conditioned zone area. VAV terminal units must never be shut down to zero when the system is operating. Also the fresh air requirements must be maintained under minimum flow conditions. Refer to Figure 5-4 and 5-5.

It should be noted that simple VAV systems sometimes cannot meet these requirements during the heating season, particularly in colder climates. To maintain air circulation it may be necessary to raise the air supply temperature by resetting the discharge temperature of the cooling coil or heating at the central unit or at terminal units.



A less favored alternative is the use of individual recirculating fans in each zone that blend room air with supply air to maintain minimum air circulation. Fans at the terminal unit increase noise levels in the space. Of the two types available, parallel fans are preferred

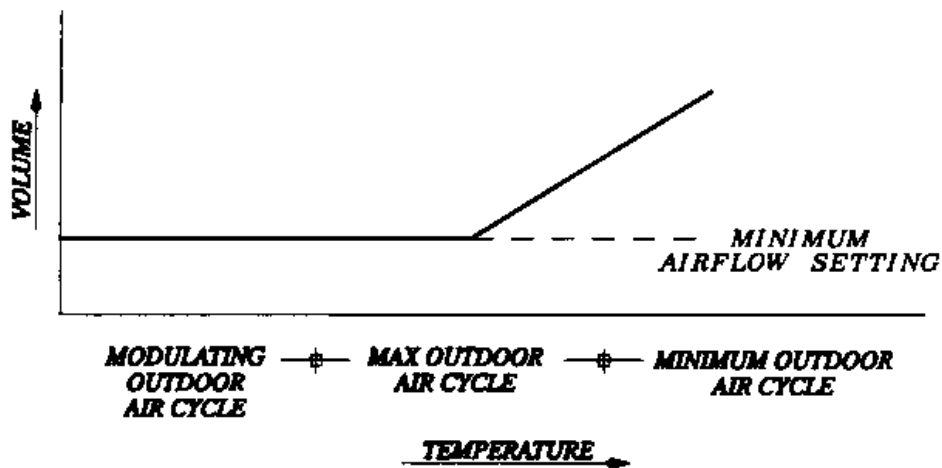

over series fans.

Figure 5-5  
Variable Volume Box

In VAV systems, the fans will remain shut down in the morning as long as the room temperature stays below the cooling set-point. This results in unacceptable temperatures and/or stagnant air during the first hour or so of occupancy. To counteract this problem, fans should be designed to run for a warm-up period prior to occupancy. Systems should also be designed so the full air volume is supplied during morning warm-up in the heating season.

In buildings where simultaneous heating and cooling are required (heating in some zones and cooling in others), two separate systems should be considered.

**Terminals.** VAV terminals should be pressure dependent unless there is a compelling reason to use pressure independent units.

Terminal ceiling diffusers or booted-plenum slots should be specifically designed for VAV air distribution. Booted plenum slots should not exceed 1 200 mm in length unless more than one source of supply is provided. "Dumping" action at reduced air volume and sound power levels at maximum CFM delivery should be minimal.

**Noise Control in VAV Systems.** System sound levels need to be checked at maximum flow. Inlet vanes and fan discharge dampers should be evaluated for noise in their most restricted position. Duct noise control should be achieved by controlling air velocity and by the use of sound attenuators not by oversizing terminal units. Volume dampers in terminal units should be located at least 1 800 mm from the closest diffuser.

Table 5-2 shows recommended duct velocities downstream from the terminal unit based on noise generation as the controlling factor.

Table 5-2  
**Recommended Duct Velocities**

Application	Controlling Factor Noise Generation (Main Duct Velocities-fpm)
Private Offices	6
Conference Rooms	
Libraries	
Theaters	4
Auditoriums	
General Offices	7.5
Cafeterias	9

### **Air Handling Units**

The air handling units described here consist of mixing boxes, filters, fans and heating and/or cooling coils. Air handling units may be factory fabricated or built-up.

**Unit Types.** The blow-through unit design allows air to be drawn through the filter section and blown through the heating and cooling coils into the supply duct.

Draw-through units consume less fan energy and provide positive control of pressure in the distribution system. Blow-through units should be used only for high pressure applications where fan power adds 10C to 20C to the supply temperature.

**Vertical and Horizontal Arrangement.** Factory-fabricated units can be assembled in a vertical or horizontal arrangement. Vertical units occupy less floor space. However, there is a 90 degree turn in the airflow as it passes through the coil section, resulting in uneven air velocity across the cooling or heating coil. It is also possible to arrange the fan discharge in a horizontal or vertical configuration. A vertical discharge should not be used if it necessitates an elbow immediately after the fan discharge.

Horizontal units occupy more floor space than vertical air handling units. Airflow through the coils is more uniform because the air does not have to turn before it enters the coil. Discharge arrangements allow lower duct losses since elbows after the fan discharge can be located farther downstream.

**Air Delivery Capacity.** Recommended air delivery capacity is 12 500 L/s per air handling unit, with 25 000 L/s being the maximum. This recommendation is based on maximizing operational flexibility for systems and tenants and minimizing energy use during after-hour operation. Units should be sized to serve no more than one smoke zone or fire protection area per floor. Casings and coils of air handling units should be sized so that the volume capacity can be increased in the future 10 percent by replacing the fan. Initial fan selection, however, should be governed optimum efficiency and performance.

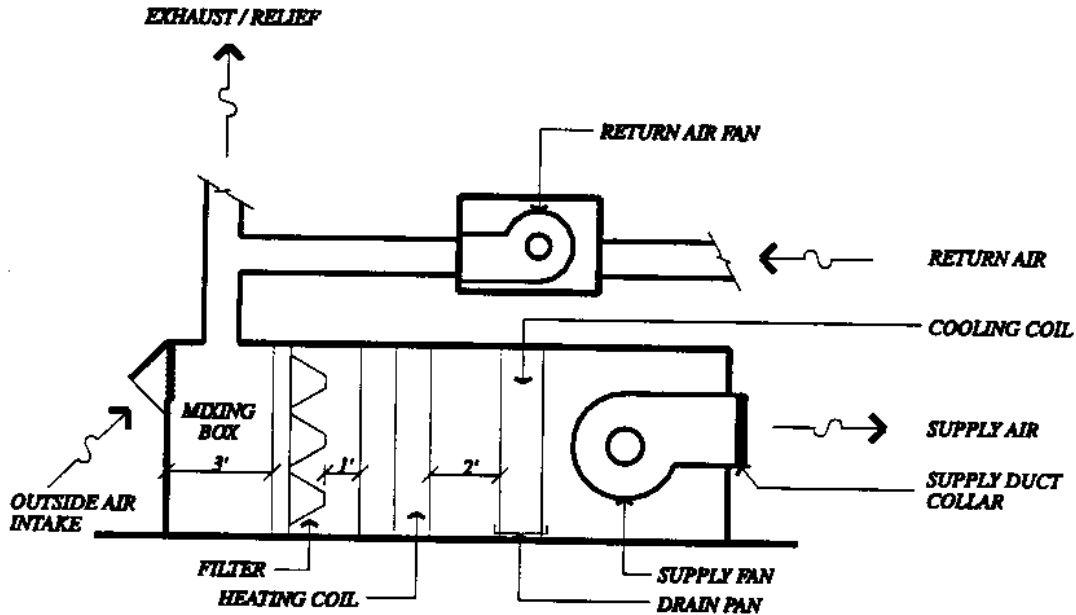

Figure 5-6  
**Horizontal Draw-Through Air Handling Unit**

**Return Air or Exhaust Fan.** A return fan provides positive return and exhaust of air from the conditioned space. It regulates pressure in the air handling unit, particularly with economizer cycle operation. Return air fans can also be used for negative pressurization. They are recommended for all air systems where static pressure in the return duct exceeds 60 Pa W.G. The return fan should be sized at lower volume than the supply fan to maintain a slightly positive pressure in the building. In highrise buildings a damper actuated by a static pressure regulator should be considered for the air return to counteract the stack effect.

**Mixing Boxes.** Mixing dampers should be placed across the full width of the air handling unit. Thorough mixing of outdoor and return air is essential for good coil performance and to prevent chilled water coils from freezing.

**Filtration.** Air filtration should be provided in every air handling system. The air handling unit should have a disposable pre-filter and a final filter. Filter media should be rated in accordance with ASHRAE 52. Pre-filters should be 30 percent to 35 percent efficient. Final filters should be 80 percent to 85 percent efficient and housed in a factory fabricated frame with a maximum bypass leakage of 0.5 percent.

Filters should be sized at 2.5 m/s maximum. Filter media should be fabricated so that fibrous shedding does not exceed levels prescribed by ASHRAE 52. The filter housing should not be lined with fibrous insulation. Double wall or an externally insulated sheet metal housing is acceptable.

The filter change-out pressure drop, not the initial clean filter rating, must be used in determining fan pressure requirements. Differential pressure gauges should be placed across filter banks to allow quick and accurate assessment of filter dust loading as reflected by air pressure loss through the filter.

**Cooling Coils.** The preferred configuration consists of no more than six row coils with fins space at least 3 mm apart, which allows for easy coil cleaning.

If a higher cooling performance is required, a second cooling coil should be installed, leaving a clear distance of 900 mm between coils. The two coils can be piped in series making them in effect one coil that is easier to clean.

**Heating Coils.** As with cooling coils, heating coils with fins spaced at least 3 mm apart are preferred.

**Humidification.** Humidification should be limited to building areas requiring special conditions. General office space should not be humidified unless severe winter conditions are likely to cause indoor humidity to fall below 25 percent. Where humidification is necessary, atomized hot water, steam or ultrasound may be used. Systems using electrical resistance heat are discouraged. Humidifiers should be centered on the air stream to prevent stratification of the moist air. Where humidification is provided, vapor barriers should be provided and the dew point of walls and windows must be documented.

**Supply Air Fans.** Vane-axial fans are efficient but are more costly than centrifugal fans. They are particularly popular for VAV systems.

Fans should be selected on the basis of watts as well as sound power level ratings at full load and at part load conditions, if variable speed. If manufacturer's ratings are not available, refer to Table 5, Chapter 52 of the ASHRAE Handbook: HVAC Systems and Applications.

Since fan sound power level increases as an exponent of static pressure, it is essential that the total system static pressure be kept small.

Fan motors should be sized so they do not run at overload anywhere on their operation curve. Fan operating characteristics must be checked for the entire range of flow conditions, particularly for forward curved fans.

**Noise Control in Air Handling Unit.** Although variable-speed drives are the most costly, they are the most energy-efficient at part-loading conditions and contribute the least to the system noise level if designed to modulate fan speed within the manufacturer's performance limitations. Variable blade pitch control is slightly noisier than variable speed drives but significantly less noisy than variable inlet vanes, particularly in low frequency bands.

All fans should be isolated. Thrust arresters should be designed for horizontal discharge fans operating at high static pressure.

**Air-side Economizer Cycle.** An air-side economizer cycle reduces cooling costs when outdoor air temperatures are below a preset high temperature limit, usually 150C to 200C, depending on the humidity of the outside air.

Either air- or water-side economizers are required for building zones that would otherwise need mechanical refrigeration in cool weather. For water-side economizers see *Cooling Systems, Special Cooling Applications* of this Chapter.

Enthalpy economizer controls are not recommended because they drift out of calibration easily and may cause energy use to increase. Economizer cycles should not be used for humidified spaces because of the increased difficulty of maintaining space humidification and control.

If economizer cycles are used in conjunction with heat reclaim chillers, care must be taken in the controls design to avoid having one concept defeat the other. If an economizer cycle is used with the cold deck of a dual duct system, temperature set points may need to be adjusted downward.

**Computer Room Air Handling.** In large computer installations it is recommended to segregate cooling of the sensible load (computer load) and control of ventilation and relative humidity by using two separate air handling units. In this design, one unit recirculates and cools room air without humidity control. This unit is regulated by a room thermostat. The second unit provides the required number of air changes and humidifies in response to a humidistat. This scheme avoids the common problem of simultaneously humidifying and dehumidifying the air.

Computer Room Air Handling. In large computer installations it is recommended to segregate cooling of the sensible load (computer load) and control of ventilation and relative humidity by using two separate air handling units. In this design, one unit recirculates and cools room air without humidity control. This unit is regulated by a room thermostat. The second unit provides the required number of air changes and humidifies in response to a humidistat. This scheme avoids the common problem of simultaneously humidifying and dehumidifying the air.

## **Ductwork**

Ductwork should be designed in accordance with ASHRAE: Handbook of Fundamentals, Chapter 33, and constructed in accordance with ASHRAE: HVAC Equipment, Chapter 1.

Generally, ductwork with the lowest possible aspect ratio and the fewest transitions will result in the lowest construction cost. Extreme aspect ratios may also increase the fan power required.



## Supply and Return Ductwork

**Ductwork Pressure.** Table 5-3 gives recommended maximum air velocities for ductwork up to 750 Pa W.G. and minimum velocities for ductwork of pressure ratings above 750 Pa W.G. The stated static pressures do not include the fan static pressure.

Table 5-3  
**Ductwork Classification**

Static Pressure	Air Velocity	Duct Class
125 Pa	10 m/s	Low Pressure
250 Pa	12.5 m/s	Low Pressure
500 Pa	12.5 m/s	Low Pressure
750 Pa	20 m/s	Medium Pressure
1 000 Pa	10 m/s	Medium Pressure
1 500 Pa	10 m/s	Medium Pressure
2 500 Pa	10 m/s	High Pressure

*Source: SMACNA HVAC Duct Construction Standards*

Pressure loss in ductwork should be minimized. This can be accomplished by using smooth transitions and elbows with a radius of at least 1 1/2 times the radius of the duct. Where mitered elbows have to be used, air foil turning vanes should be provided. Mitered elbows are not permitted where duct velocity exceeds 12.5 m/s.

Supply and return air ducts should be designed to allow no more than 3 percent leakage of total airflow in systems up to 750 Pa W.G. In systems from 750 Pa W.G. through 2 500 Pa W.G. ducts should be designed to limit leakage to 0.5 percent of the total air flow.

**Sizing of Ductwork.** Supply ductwork should be sized using the static pressure regain method, while return duct can be designed using the equal friction method. The static pressure regain method saves energy and ensures a relatively stable entering static pressure at the terminals in VAV systems.

Ductwork should be sized to permit a reasonable amount of relocation of air diffusers in the future. In buildings with large areas of open plan space this means oversizing of the duct system. The final third of the duct length should be sized at 30 percent additional air volume. Air flow diversity should also be a sizing criterion. Full diversity can be taken at the air handling unit and decreased the farther the ductwork is from the source until no air flow diversity is taken for the final third of the system.

**Ductwork Construction.** Generally, ductwork should be fabricated from galvanized sheet metal. Flex duct may be used for low pressure ductwork downstream of the terminal box in office spaces. The length of the flex duct should not exceed the distance between the terminal box and the diffuser plus 20 percent to permit relocation of diffusers in the future while minimizing replacement of ductwork. Generally, flex duct runs should not exceed 3 m nor contain more than two bends.

Joint sealing tape for all connections must be of reinforced fiberglass backed material with field applied mastic. Pressure sensitive tape should not be used as the primary sealant.

**Insulation.** All supply ducts must be insulated, in accordance with ASHRAE Standard 90.1.

**Ceiling Plenum Supply.** Plenum supply does not permit adequate control of and cleanliness of supply air and should not be used. In computer rooms, underfloor plenum supplies are appropriate.

**Plenum and Ducted Returns.** A plenum return is a very attractive option in office space because it facilitates future reorganization of the space considerably. With a return plenum care must be taken to ensure that the air drawn through the most remote register actually reaches the air handling unit. The horizontal distance from the farthest point in the plenum to a return duct should not exceed 50 m. No more than 2400 L/s should be collected at any one return grille. Figure 5-7 illustrates an example of an open ceiling plenum with a minimal amount of return air ductwork. All return risers must be ducted.

Other, less flexible building spaces, such as permanent circulation, public spaces and support spaces, should have ducted returns. Where fully ducted return systems are used, consider placing returns low in walls or on columns.

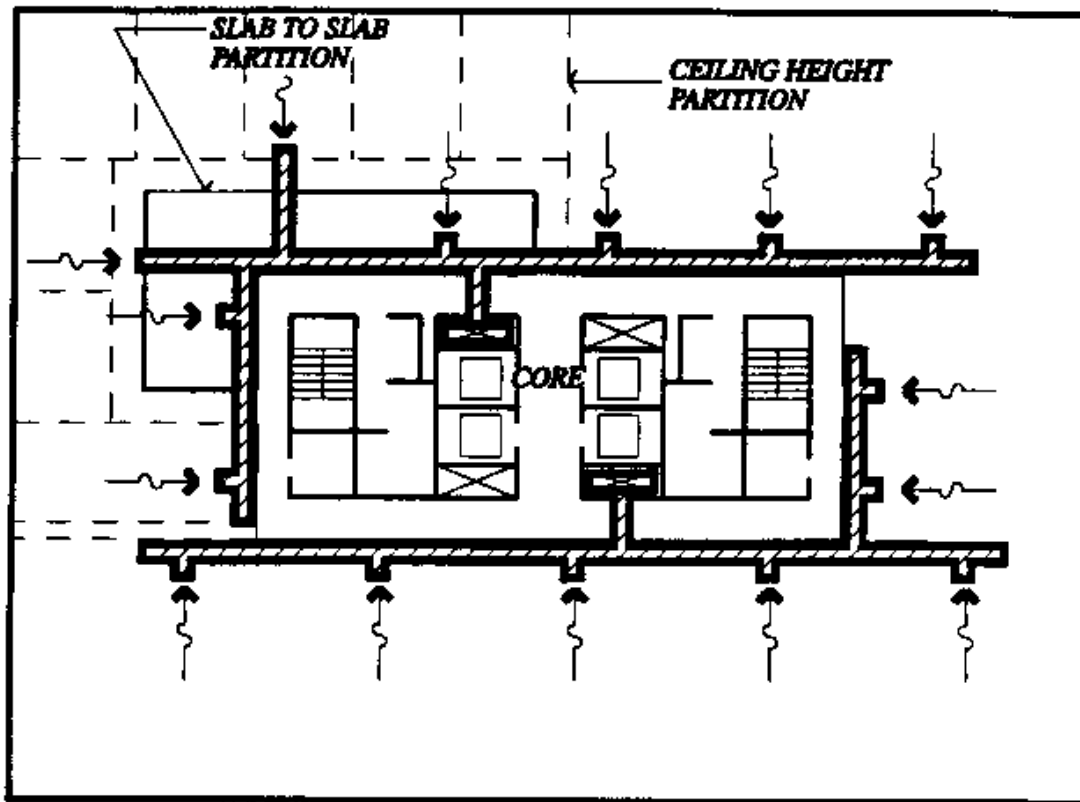

Figure 5-7  
Ceiling Return Plenum with Minimal Return Ductwork

**Noise Control.** The generation of noise at duct fittings on low-velocity systems is usually not critical. However, a doubling of velocity increases the sound power level of fittings by approximately 15 dB. In high-velocity systems, fittings can become a significant noise source. Therefore, these systems should avoid components such as mitered elbows, conventional and acoustical turning vanes, bullhead tees, balancing dampers and splitters. Air-foil smoke dampers should be used instead of in-stream fire dampers.

Connections between central fans and supply ducts should be with fireproof fiber cloth sleeves without offset between fan outlet and duct.

**Duct Liners.** Duct liners, if used for noise reduction, must comply with ASTM C-1071. Adhesives must comply with ASTM C-916.

## **Exhaust Duct Systems**

All exhaust ductwork should comply with the duct leakage provisions stated above for supply and return air.

Kitchen exhaust duct systems must comply with the building code and NFPA 96. Exposed exhaust ductwork should be of welded stainless steel construction: concealed duct may be of black iron. Ducts must be provided with drains at low points.

For large kitchen hoods, auxiliary air intakes, which supply outside air directly to the hood, should be considered.

Chemical fume exhaust must meet the requirements of the building code and NFPA 45. Exhaust ductwork should be of stainless steel or fire-rated, fiberglass-reinforced plastic construction, in accordance with the type of fume expected and compatible with the functional process needs.

## Special Systems

### Heat Recovery

Heat recovery utilizes heat generated by internal loads or mechanical equipment within a building to the fullest extent possible before rejecting it. This minimizes the amount of heat that must be added for comfort conditioning.

**Heat Reclaim Chillers.** Heat recovery chillers should be considered for buildings that will require cooling year round. If used in conjunction with air-side economizer cycles, a careful controls design is required to prevent the two approaches from working against each other.

**Exhaust Air Heat Recovery.** Where more than 1900 L/s of air is exhausted and replaced by heated make-up air, heat recovery should be considered.

**Heat Exchangers.** The condenser water system or a separate 24-hour critical load system can be connected via heat exchanger to the hot water heating system.

### Thermal Storage

Thermal storage systems use previously manufactured ice or chilled water rather than running chillers on demand. Their major advantage lies in the ability to control time of day electrical demand.

Thermal storage should be considered on all building projects with large cooling loads. It can be an important operating cost consideration if the power company employs demand charges, ratchet clauses and/or time of use charges. With thermal storage, refrigeration machinery can be run at the time the lowest electrical rates are in effect. With refrigeration running at night and fans and pumps during the day, power usage is evened out. In the evaluation of this cooling option, a detailed comparison of rate structures is in order.

Thermal storage also provides flexibility for the future as rate structures change. Some power companies will pay for an engineering feasibility study of thermal storage in an effort to encourage demand side management of large consumers.

Thermal storage systems also have operational advantages. The refrigeration equipment in thermal storage systems can operate at full load conditions most of the time, rendering it more efficient than conventional chillers. In addition, since the system typically operates at night, when outdoor air temperatures are cooler, condenser heat rejection is improved.

Thermal storage permits use of smaller, less costly refrigeration compressors, whose reduced electrical load can result in a lower-cost power distribution system. In addition, when ice is used as the storage medium, lower supply water temperature and a large temperature differential can be employed. Although low temperature air distribution is sometimes used in conjunction with thermal storage, the impact on room air distribution may be a problem. This can be overcome with face and by-pass air handling units or fan powered VAV boxes.

In most buildings, conventional cooling is considered a non-essential load and, thus, is not connected to standby power generation equipment. The relatively small on-peak load imposed by the fans and pumps of a thermal storage system may make it possible to connect critical areas to emergency power, which would ensure continued cooling during power outages.

Thermal storage systems have some drawbacks that should be taken into account in the system design. These are a higher first cost and a requirement for larger amounts of space. A lack of familiarity with these systems can lead to operational problems.

## **Solar Heating and Cooling**

For each new project, renewable energy sources shall be considered for heating, cooling and domestic hot water heating. If cost effective, renewable sources (solar energy, wind, water) shall be utilized.

## Plumbing Systems

### Stormwater Drainage System

Stormwater drainage must always be designed as a system separate from the sanitary sewer throughout the building and site, even when both discharge into the same public system.

### Sanitary Sewer System

**Automatic Sewage Ejectors.** Sewage ejectors should only be used where gravity drainage is not possible. If they are required, only the lowest floors of the building should be connected to the sewage ejector; fixtures on upper floors should use gravity flow to the public sewer.

Sewage ejectors should be non-clog, screenless duplex pumps, with each discharge not less than 100 mm in diameter. They should be connected to the emergency power system.

**Acid Wastes.** If certain functions in a building produce acid wastes, a separate acid waste and vent system should be designed. This system should incorporate a neutralizing tank with pH treatment and/or water dilution. If the amount of anticipated waste is small and confined to very few points in the building, local neutralization devices, such as limestone chip filters, may be considered.

### Domestic Water

**Pressure Reducing Valves.** Pressure reducing valves should be installed where water pressure exceeds 500 kPa. A valved by-pass should be provided.

**Exterior Wall and Yard Hydrants.** Unless the site is provided with a sprinkler system for landscape watering, wall and yard hydrants should be provided. They should be located so every area can be reached with a 30 m hose. The hose should not have to cross the walkway to the building entrance. In climates with frost danger, yard hydrants must be drainable. Each wall and yard hydrant should be equipped with a vacuum breaker. See Chapter 2: *Site Planning and Landscape Design, Site Utilities, Hosebibs and Irrigation for Landscaping.*

### **Domestic Hot Water**

Both hot and cold water should be supplied to lavatories and showers. Single temperature faucets are not permitted at lavatories. Hot water tanks should maintain water temperature at not less than 140°F to prevent bacterial growth unless some other technique is used for this purpose. Kitchen equipment should be supplied with high temperature water (180°F) from a separate heating system.

**Hot Water Heating.** Rejected heat should be used to preheat domestic hot water systems wherever feasible.

Instantaneous type heaters are not recommended because of the difficulty of adequate temperature control. With indirect systems, careful attention must be given to the potential of leaks from the heat exchangers into the domestic hot water. Double-wall vented tubing is recommended.

Water heaters should be sized in accordance with ASHRAE: *HVAC Systems and Applications.*

**Point of Use Hot Water Heater.** In buildings where the amount of water used is small and locations of use are spread out, point-of-use hot water heaters may be more appropriate than central systems. They eliminate the need for hot water piping and can be turned off when the building is unoccupied. Electric type heaters are recommended for use in toilet rooms.

**Recirculation.** Recirculating piping should be provided for all hot water systems where the piping from the heater to the fixtures is more than 30 m.



A check valve should be provided in the main return to prevent temporary reversal of flow.

### **Plumbing Fixtures**

Plumbing fixtures should be commercial grade or better. Water conserving fixtures should be used. Fixtures designated for use by the handicapped must comply with the requirements of Federal Standard 795: Uniform Federal Accessibility Standards and the requirements of the Title III Standards for the Americans with Disabilities Act.

**Drinking Fountains.** Drinking fountains should supply 130C water, either from standard packaged electric water coolers or from a central supply. The use of CFC's for refrigeration is not permitted.

### **Natural Gas Systems**

**Service Entrance.** Gas piping entering the building must be protected from accidental damage by vehicles, foundation settlement or vibration. Where practical, the entrance should be above grade and provided with a self-tightening swing joint prior to entering the building.

**Gas Piping within Building Spaces.** Gas should not be piped through confined spaces, such as trenches or unventilated shafts. All spaces containing gas fired equipment, such as boilers, chillers and generators, should be mechanically ventilated. Vertical shafts carrying gas piping should be ventilated at top and bottom to prevent leaked gas from accumulating.

Diaphragms in gas piping must be vented to the outside.

## **Pumping Systems**

### **Hydronic, Closed Loop Systems**

Closed piping systems are unaffected by static pressure, therefore, pumping is required only to overcome static friction. Pumps used in closed loop hydronic piping should be designed to operate to the left of the peak efficiency point on their curves (higher head, less flow). This compensates for variances in pressure drop between calculated and actual values without causing pump overloading. Pumps with steep curves should not be used as they tend to limit system flow rates.

**Variable Flow Pumping.** Variable flows occur when control valves are used to modulate heat transfer. The components of a variable volume pumping system include pumps, distribution piping, control valves and terminal units, and will also include boilers and chillers unless a primary-secondary arrangement is used. All components of the system are subject to variable flow rates. It is important to provide a sufficient pressure differential across every circuit to allow design flow capacity at any time.

Flow may be varied by variable speed pumps or staged multiple pumps. Pumps should operate at no less than 75 percent efficiency for their performance curve. Variable flow pumping must be designed carefully. Package systems should be used, with pumps and controls supplied by the same manufacturer.

Chillers and most boilers may experience flow related heat exchange problems if flow is not maintained above a minimum rate. For this reason, separate, constant flow primary water pumps are recommended for variable volume pumping systems.

**Primary/Secondary Pumping.** In this application, primary and secondary circuits are separate, with neither having an effect on the pumping head of the other. The primary circuit usually serves source equipment (chiller or boiler), while the secondary circuit serves the load.

It is easier to control flows in the secondary circuit because the pressure differential across control valves is a larger percentage of the pump head requirements which is comparable to a primary pump system arrangement. On the primary side it is possible to tie the system into a campus distribution loop.

Primary/secondary systems are recommended for larger buildings.

## Piping Systems

All piping systems should be designed in accordance with ASHRAE *Handbook of Fundamentals* and the ASHRAE Handbook on *HVAC Equipment*, Chapter 34.

**Cathodic Protection.** The need for metal protection for underground piping must be evaluated by a soils resistivity test. This is part of the Geotechnical Report. See GSA document *Submission Requirements for Design and Construction (PBS-PQ280)*. Cathodic protection or another means of preventing pipe corrosion must be provided.

**Piping Material.** Table 5-4 cites which commercial standard should be used for piping material.

Table 5-4  
**Commercial Standards for Piping Material**

Standard Piping Material	Use	Comments
ASTM Schedule 40	Chilled water up to 300 mm diameter, Condenser water up to 300 mm diameter	035 kPa fittings. Standard weight pipe over 300 mm diameter.
	Hot water	Test to 2 100 kPa
	Natural gas	Weld and test to 2 100 kPa
	Steam to 100 kPa	
ASTM Schedule 80	Steam over 100 kPa	Test to 3 450 kPa
	Steam condensate	
Copper Tubing	Chilled water, Condenser water	Builder's option. Use type K below ground and type L above
	Domestic water	Leadfree solder connections.
	Refrigeration	Type ACR
Cast Iron	Sanitary, waste and vent	
	Storm	

**Isolation of Piping at Equipment.** Isolation valves, shut-off valves, by-pass circuits and unions should be provided as necessary for piping at equipment to facilitate equipment repair and replacement. Equipment requiring isolation includes boilers, chillers, pumps, coils, terminal units and heat exchangers. Valves should also be provided for zones off vertical risers.

**Provisions for Piping in Earthquake Zones.** In Seismic Zones 2, 3 and 4, sleeves for pipes should be at least 25 mm larger than the pipe, to allow for movement. Flexible couplings should be provided at the bottom of pipe risers. Spreaders should be used to separate adjacent pipes, unless the distance is large enough to prevent contact in an earthquake. See Chapter 4: *Structural Engineering, Attachment of Non-Structural Elements, Piping, Conduit and Ductwork* for more detailed information.

**Piping System Identification.** All pipes in mechanical rooms, shafts, ceilings and other spaces accessible to maintenance personnel must be identified with color coded bands indicating type of material piped and direction of flow. Gas piping and sprinkler lines must be identified as prescribed by NFPA.

Valves and other operable fittings must be tagged.

## **Vibration Isolation, Acoustical Isolation and Seismic Design for Mechanical Systems**

### **Noise and Vibration Isolation**

Isolate all moving equipment in the building.

**Mechanical Room Isolation.** Floating isolation floors should be considered for major mechanical rooms located in penthouses or at intermediate levels in midrise and highrise construction. See Chapter 3: *Architectural and Interior Design, Special Design Considerations, Acoustics, Design Criteria for Building Spaces, Class X Spaces.*

**Mechanical Chases.** Mechanical chases should be closed at top and bottom, as well as the entrance to the mechanical room. Any piping and ductwork should be isolated as it enters the shaft to prevent propagation of vibration to the building structure. All openings for ducts and piping must be sealed, except that shafts dedicated to gas piping must ventilated.

**Isolators.** Isolators should be specified by type and by deflection, not by isolation efficiency. See ASHRAE Guide for Selection of Vibration Isolators for types and minimum deflections. Specifications should be worded so that isolation performance becomes the responsibility of the equipment supplier.

**Concrete Inertia Bases.** Inertia bases should be provided for reciprocating and centrifugal chillers, air compressors, all pumps, axial fans above 300 RPM, and centrifugal fans above 35 kW.

**Ductwork.** Reduce fan vibrations immediately outside any mechanical room wall by acoustically coating or wrapping the duct.

**Piping Hangers and Isolation.** Isolation hangers should be used for all piping in mechanical rooms and adjacent spaces, up to a 15 000 mm distance from vibrating equipment. The pipe hangers closest to the equipment should have the same deflection characteristics as the equipment isolators. Other hangers should be spring hangers with 20 mm deflection.

Positioning hangers should be specified for all piping 200 mm and larger throughout the building. Spring and rubber isolators are recommended for piping 50 mm and larger hung below noise sensitive spaces.

Floor supports for piping may be designed with spring mounts or rubber pad mounts. For pipes subject to large amounts of thermal movement, plates of teflon or graphite should be installed above the isolator to permit horizontal sliding.

Anchors and guides for vertical pipe risers usually must be attached rigidly to the structure to control pipe movement. Flexible pipe connectors should be designed into the piping before it reaches the riser.

## **Layout of Mechanical Spaces**

**Vertical Clearances.** Mechanical equipment rooms generally should have clear ceiling heights of not less than 3 600 mm. Catwalks should be provided for all equipment that cannot be maintained from floor level. Where maintenance requires the lifting of heavy parts (90 kg or more), hoists should be installed.

**Horizontal Clearances.** Mechanical rooms should be laid out with clear circulation aisles and adequate access to all equipment.

Chillers should be placed to permit pulling of tubes from all units. The clearance should equal the length of the tubes plus 600 mm. Air handling units require a minimum clearance of 750 mm on all sides, except the side where filters and coils are accessed. The clearance on that side should equal the length of the coils plus 600 mm.

**Lighting.** Lighting in equipment rooms should be laid out so as not to interfere with equipment.

**Housekeeping Pads.** Housekeeping pads should be at least 75 mm larger than the mounted equipment on all sides.

**Piping.** Piping should be laid out in an orderly fashion. Access to the underside of the structure should not be completely cut off.

**Ductwork.** Ductwork should be laid out with a minimum of bends. Access to piping and the underside of the structure should not be obstructed.

**Operation and Maintenance Manuals.** Documentation on all building systems should be provided for the guidance of the building engineering staff. This should show the actual elements that have been installed, how they performed during testing, and how they operate as a system in the completed facility.



The building staff should be provided with the following:

Record drawings and specifications.

Operating manuals with a schematic diagram, sequence of operation and system operating criteria for each system installed.

Maintenance manuals with complete information for all major components in the facility.

**Posted Instructions.** Posted operating instructions are required for manually operated mechanical systems. They should consist of simplified instructions and diagrams of equipment, controls and operation of the systems, including boilers, refrigeration equipment, HVAC controls, hot and chilled water distribution and hot and cold domestic water.

Instructions should be framed and posted adjacent to the major equipment of the system.

**Operating Instructions.** Operating instructions should be provided for maintenance staff at the time of commissioning the mechanical systems. The amount of instruction time provided should be commensurate with the complexity of each system.

## **Control Systems**

### **Automatic Temperature and Humidity Controls**

Control systems and strategies should be kept as simple as possible to minimize first cost, improve reliability and simplify operation of the systems. More sophisticated control strategies which can be shown to save energy or reduce life cycle costs should be considered but only applied where not detrimental to overall system reliability and maintainability.

**Controls.** Pre-programmed single or multiple loop controllers should be used to control all HVAC and plumbing sub-systems.

**Temperature Controls.** Heating and cooling energy in each zone should be controlled by a thermostat located in that zone. Independent perimeter systems must have at least one thermostat for each façade of the building with a different orientation.

Heating and cooling to spaces should be sequenced, not provided simultaneously. A 30C deadband should be used between heating and cooling operations.

Night set-back controls for the heating season and for summer conditions must be provided for all comfort conditioned spaces, even if initial building occupancy plans are for 24-hour operation. Morning warm-up must be part of the control system.

### **Temperature Reset Controls**

**Air Systems.** Systems supplying heated or cooled air to multiple zones must include controls that automatically reset supply air temperature by representative building loads or by outside air temperature. Temperature should be reset by at least 25 percent of the design supply-air to room-air temperature differential. Zones that are expected to experience relatively constant loads, such as interior zones, may be designed for the fully reset supply temperature.

**Hydronic Systems.** Systems supplying heated and/or chilled water to comfort conditioning systems must also include controls that automatically reset supply water temperatures by representative building loads (including return water temperature) or by outside air temperature.

Exceptions are:

- Systems where it can be shown that supply temperature reset increases overall building annual energy use;
- Systems for which supply temperature reset controls cannot be implemented without causing improper operations of heating, cooling, humidification, or dehumidification systems; or
- Systems with less than 240 kW design capacity.

## **Testing and Balancing Equipment and Systems**

**Testing Stations.** Permanent or temporary testing stations should be provided to permit testing of building systems. Connections should be designed so temporary testing equipment can be installed and removed without shutting down the system.

Airflow measuring grids are required for all central air handling units. Measuring grids should be provided at the supply duct and the return duct.

Airflow measuring grids must be sized to give accurate readings at minimum flow. It may be necessary to reduce the duct size at the station to permit accurate measurement.

Water flow measuring devices are required for each refrigeration machine and for chilled water lines serving computer rooms and outleased spaces. Water flow totaling devices should also be included at the boiler and hot water lines to outleased spaces.

**Thermometers and Gauges.** Each measuring point should have instrumentation to verify capacities, temperatures, flow rates and any other critical parameters.

Thermometers and pressure gauges are required on the suction and discharge of pumps, chillers, boilers, heat exchangers, cooling coils, heating coils and cooling towers.

Duct static pressure gauges should be provided for the air supply fan or in individual duct runs, if multiple pressure measurement is used.

Pressure gauges should be placed on both sides of filters in the air handling unit.

A static pressure gauge should be provided to measure building pressure.

A temperature gauge is required at the outside air intake.

## Building Automation System (BAS)

The primary reason for using a Building Automation System (BAS) is the anticipated lower operating cost over the life of the building. Programmable controllers direct building systems to minimize overall power and fuel consumption; monitor systems such as elevators, security controls and fire alarms; cycle equipment for preventive maintenance and maintain parts inventories. For optimal function, the BAS should be integrated with the basic building controls system.

A BAS is not required for every project. The size of the building, number of pieces of equipment, expected energy savings and availability of trained staff should all be considered before a decision is made. BAS systems are mandatory on large, new buildings and major modernizations.

**Level of Integration.** It is possible to combine controls for practically all building systems - HVAC, lighting, emergency power and elevators - into a single-CPU operating unit. Since the advent of micro-computer BAS systems, it has been tempting to integrate as many systems as possible to reduce hardware requirements.

Caution is advised, however, when planning BAS systems with a high level of integration. The more integration, the more complex the system becomes and the more training is required for the operating staff. Also, reliability requirements for the different systems may vary.

Fire alarm systems and security systems should not be integrated into the BAS. See Chapter 7: *Fire Protection Engineering, Electrical Requirements, Fire Alarm System, Integration of Systems* and Chapter 8: *Security Design, Security System Design*.

**Software.** All BAS systems come with preprogrammed software. Prior to specifying a manufacturer's product it is critical to research the off-the-shelf programs available for the system to ensure that they match the desired operating characteristics. Custom programming is highly undesirable, as it will always cost more to program, install and debug new software than to pay for even the most expensive ready-made program.

BAS software must become the property of the Government after building occupancy.

**Energy Conservation.** The best targets for energy conservation in building systems are the HVAC system and the lighting system. Useful HVAC programs include optimized start/stop for chillers and boilers and feed-forward controls based on predicted weather patterns.

Optimal start/stop calculates the earliest time systems can be shut down prior to the end of occupancy hours and the latest time systems can start up in the morning with the aim of minimizing equipment run time without letting space conditions drift outside comfort set points.

Weather prediction programs store historic weather data in the processor memory and use this information to anticipate peaks or part load conditions. Programs also run economizer cycles and heat recovery equipment.

A number of programs are available to control building lighting. They include timers and sweeps for on/off control and photocell controlled switching for taking full advantage of daylight.

**Maintenance Scheduling.** Programs to be considered are those that switch pumps and compressors from operating equipment to stand-by on a scheduled basis. Likewise, there are programs that provide maintenance schedules for equipment in every building system, including information on what parts and tools are needed to perform each task.

**System Design Considerations.** Building automation systems require measurements at key points in the building system and must be capable of part-load operation recognition and be equipped with controls to match system capacity to load demands. Controls cannot correct inadequate source equipment, poorly selected components, or mismatched systems.

Energy efficiency requires a design that is optimized by realistic prediction of loads, careful system selection, and full control provisions.

In new buildings and major renovations, the BAS should have approximately 20 percent spare capacity for future expansion. The system must provide for stand-alone operation of subordinate components.

No matter how sophisticated, BAS systems must be easy to understand and manipulate by building engineering staff. In the past overly complicated systems have been disconnected by engineering staff.

**Energy Measurement Instrumentation.** The capability to allow building staff to measure energy consumption and monitor performance is critical to the overall success of the system. Electrical values, such as V, A, KW, KVAR, KVA, PF, KWH, KVAH, Frequency and Percent TDH, should be measured. See also Chapter 6: *Electrical Engineering, Site Distribution, Secondary Distribution, Submetering* for separate metering of power consumption.

## **Alterations in Existing Buildings and Historic Structures**

The goal of alteration projects is to meet the facilities standards described in this document for new projects. Renovation and rehabilitation designs must satisfy the immediate occupancy needs and anticipate additional future changes. Remodeling should make building systems become more flexible not less.

Alteration projects can occur at three basic scales: refurbishment of an area within a building, such as a floor or a suite; major renovation of an entire structure; and upgrade/restoration of historic structures.

In the first instance, the aim should be to satisfy the new requirements within the parameters and constraints of the existing systems. The smaller the area in comparison to the overall building, the fewer changes to existing systems should be attempted.

In the second case, the engineer has the opportunity to design major upgrades into the mechanical, electrical and communications systems. The mechanical services can come close to systems that would be designed for a new building, within the obvious limits of available physical space and structural capacity.

Where a historic structure is to be altered, special documents will be provided by GSA to help guide the design of the alterations. The most important of these is the Historic Building Preservation Plan (HBPP) which identifies zones of architectural importance, specific character-defining elements that should be preserved, and standards to be employed. See Chapter 1: *General Requirements, Applicability of the Facilities Standards, Types of Facilities, Historic Buildings*.

Modern standards for climate control developed for new construction may not be achievable or desirable for historic buildings. In each case, the lowest level of intervention needed to successfully accomplish the project should be selected. When a system is designed, it is important to anticipate how it will be installed, how damage to historic materials can be minimized, and how visible the new mechanical system will be within the restored or rehabilitated space.

The following guidelines should be followed for HVAC work in historic buildings:



- Reduce heating and cooling loads to minimize size and other impacts of modern equipment.
  - Calculate the effect of historic building features such as wall thickness, skylights, and porticos, interior design features such as draperies, shutters and window shades, and existing site features such as landscaping.
  - Add insulation where not visible and intrusive, such as attics or basements. Insulate walls only where it can be done without removal or covering original visible elements.
  - Add storm windows where they can be installed in manner that will not detract from original visible elements.
  - Use new replicated thermal windows only where it is not economically feasible to repair existing windows.
- Select systems' other characteristics to minimize impact.
  - Retain decorative elements of historic systems where possible. Grilles and radiators should be kept even if they do not function as originally intended.
  - Retain the original type of system where a new one cannot be totally concealed. For example, reuse existing radiators with new distribution piping or replace with modern heating-cooling units, rather than adding another type of system that would require the addition of new ceilings or other non-original elements.
  - Use a number of smaller units in lieu of a few large ones. Insure that room is available to maintain and replace equipment without damaging significant features.
  - Place new distribution systems out of sight whenever possible by using closets, shafts, attics and basements.
  - Use custom rather than commercial standard products where elements are exposed in formal areas.

- Select temperature and humidity conditions that will not accelerate deterioration of building materials. GSA has no official conditions but rather uses ones that are customary and reasonable for the intended use.
- Where equipment is near significant features, insure that leakage from pipes and HVAC units will not cause deterioration. Use deeper pans, lined chases and leak detectors.
- Design HVAC systems to avoid impacting other systems and historic finishes, elements and spaces.
  - Place exterior equipment where it is not visible. Be particularly careful with new chimneys or vents and condensers, towers, solar panels and air intakes.
  - Locate equipment with particular care for weight and vibration on older building materials. These materials may not accept the same stress as when the equipment is used with newer construction methods.
  - If new ceilings must be installed, insure that they do not block any light from the top of existing windows. This is the area of highest natural illumination, and it can be used to reduce the need for artificial illumination, which will in turn reduce the size of HVAC systems.

Alteration design requires ingenuity and imagination. It is inherently unsuited to rigid sets of rules. Each case is unique. The paragraphs that follow in this section should be viewed as guidelines and helpful hints to be used when appropriate and disregarded when not.

### **Evaluation of Existing Systems**

Every alteration project includes an evaluation which describes the physical condition of building systems, identifies variances from present codes, and notes available capacity for structural, mechanical, electrical and communications systems.

### **Code Requirements for Alterations**

For most major renovations an evaluation of code deficiencies is appropriate. See Chapter 1: *General Requirements, Codes and Standards, Building Codes* for required evaluation.

Generally, code deficiencies should only be corrected within the alteration area. However, upgrades may also be required for equipment supporting the alteration area but located outside of it.

New work should always meet code. An exception would occur when code compliance in new work would create a hazard to the existing system. Alterations in buildings where all systems are replaced must follow current codes.

### **Placing Mechanical Systems in Renovated Buildings**

Even more than in new construction, the optimal placement of engineering systems in the building structure is a crucial element in the success of the alteration. Vertical and horizontal distribution of utilities must be integrated into the architectural concept from the outset.

Chapter 3: *Architectural and Interior Design, Alterations in Existing Buildings and Historic Structures, Placing Mechanical and Electrical Systems in Renovated Buildings* describes some of the strategies available for placement of mechanical systems.

**Vertical Distribution.** If new risers are required, they should preferably be located adjacent to existing shafts.

**Horizontal Distribution.** Fortunately, many older buildings have high floor-to-floor heights, which permit an expansion of an existing ceiling space.

In buildings containing ornamental or inaccessible ceilings, piping and ductwork may have to be run in furred wall space or exposed in the occupiable building area. Exposed ducts must be designed to complement the building architecture in forms and materials used.

### **General Design Considerations for Alterations**

**Re-use of Existing Equipment.** Existing equipment can be re-used or modified if it is in good condition. Equipment for which replacement parts are no longer available should generally be replaced during alterations. If existing equipment is to be modified, components should be specified by manufacturer's name and model number to ensure compatibility and continuation of any applicable warranties.

**Removal of Materials Not Re-used.** Ductwork and piping should be removed not abandoned in place, unless removal is impossible.

**Hazardous Material.** Any hazardous materials in the renovation area must be abated or disposed of in accordance with EPA regulations.

**Phasing.** In occupied buildings phasing of construction should be planned to minimize disruptions.

**Cost Considerations.** Design decisions should be based on meeting the needs of current as well as future users and cost. A life cycle cost analysis is only required if wholesale changes for mechanical systems are contemplated. The reasons for selections should be documented.

# **CHAPTER 6 ELECTRICAL ENGINEERING**

## **General Approach**

Electrical and communications systems in GSA buildings provide the infrastructure for an efficient work environment for the occupants. These systems must support the many types of equipment used in a modern office setting in a reliable fashion.

There are three characteristics that distinguish GSA buildings from buildings built by private developers: long life span, changing occupancy needs, and the use of a life cycle cost approach to account for total project cost.

GSA owns and operates its buildings much longer than the private sector. Consequently, a higher level of durability is required for all systems, as is the ability to replace equipment during the life of the building.

During the life span of a typical Federal building, many minor and major alterations are necessary as the missions of Government agencies change. The flexibility to adjust to alterations easily must be designed into the building systems from the outset. Electrical and communications systems should provide ample capacity for increased load concentrations in the future and allow modifications to be made in one area without causing major disruptions in other areas of the facility.

Private developers base their costs on the amortization of the original building shell and standard tenant fit-up. All later requirements are done as an expense to the tenant. GSA, although still charging expense to the tenant, uses a life cycle cost approach to minimize the total cost to the Federal Government, which is both landlord and tenant. The result is that GSA capitalizes a higher proportion of the initial cost than a private developer.

It is GSA's goal to build facilities equipped with the latest advances in office technology and communication. This intent should be extended to include the future evolution of automated office and telecommunications equipment as well. Making this concept a reality requires a comprehensive design for engineering systems that goes beyond the requirements of the immediate building program. It also requires a higher level of integration between architecture and engineering systems than one would usually expect in an office building.

The trend toward intelligent buildings is gaining momentum in the Federal sector. The Government recognizes that communication needs and technology are growing at an increasingly rapid pace. Work stations are becoming more powerful, requiring faster and easier access to more information. GSA must install the wiring and interfaces to support these requirements. It should be noted that the design of all communication systems is the responsibility of GSA's Information Resources Management Service (IRMS).

A computer-based building automation system (BAS) that monitors and automatically controls lighting, heating, ventilating and air conditioning is critical to the efficient operation of the modern Federal office building. GSA encourages integration of building automation systems generally. Exceptions are the fire alarm and security systems, which should function as stand-alone systems with a monitoring only interface to the BAS.

## Codes and Standards

Model codes and standards adopted by GSA are discussed in Chapter 1: *General Requirements, Codes and Standards, Building Codes*. All electrical and communications systems must meet or exceed the requirements of the National Electric Code (NEC).

### Electrical Design Standards

The standards listed below are intended as guidelines for design only. They are mandatory only where referenced as such in the text of the chapter. The list is not meant to restrict engineers from using additional guides or standards as desired.

Electronic Industries Association/Telecommunications Industry Association (EIA/TIA) Standard 569: Commercial Building Standard for Telecommunication Pathways and Spaces.

Illuminating Engineering Society of North America (IES) Lighting Standards.

Institute of Electrical and Electronic Engineers (IEEE) Standards.

Federal Information Processing Standard 5-91.

National Electrical Manufacturers' Association (NEMA) Standards.

Insulated Power Cable Engineers' Association (IPCEA) Standards.

Certified Ballast Manufacturers' Association (CBMA) Standards.

National Fire Protection Association (NFPA).

Rules and regulations of local utility companies.

## **Placing Electrical Systems in Buildings**

In order to achieve system flexibility and thorough integration between building architecture and engineering systems, a concept for the distribution of electrical and communications systems must be established during the architectural schematic design. The locations of vertical and horizontal elements of electrical and communications distribution equipment must be established before the architectural concept is finalized.

**Electrical Closets.** The spacing of electrical and communications closets in buildings is described in Chapter 3: *Architectural and Interior Design, Building Planning, Placement of Core Elements and Distances*. Electrical closets must be stacked vertically and located so that the length of branch circuits does not exceed 45 m. Shallow, secondary closets off permanent corridors may be used for receptacle panelboards where the distance between the riser and the farthest work station exceeds 45 m and a separate riser is not warranted.

Electrical closets should be designed to contain adequate wall space and clearances and should have a minimum size of 1 800 mm by 3 000 mm.

**Communications Closets.** Communications closets shall meet the requirements of EIA/TIA Standard 569. Communications closets must be stacked vertically and must be placed so that wiring runs do not exceed 75 m. Closets should be sized to contain adequate floor space for frames, racks and working clearances. The minimum closet size is 2 400 mm by 300 mm. Plywood boards should be provided on at least one wall for placement of telephone equipment.

**Planning Grid, Floor Grid and Ceiling Grid.** A common planning module is to be used in all GSA buildings. The relationship of this module to wall placement, ceiling grids and location of mechanical and electrical elements is described in detail in Chapter 3: *Architectural and Interior Design, Building Planning, Planning Module, Floor-to-Floor Heights and Vertical Building Zoning and Space Planning, Office Space, Floor and Ceiling Grids*. Electrical and communications elements in floors and ceilings - lights, power, telephone and data - are given precise locations (refer to Figure 6-1). For convenience, the sketches are repeated here, but readers are advised to see the applicable sections in Chapter 3.



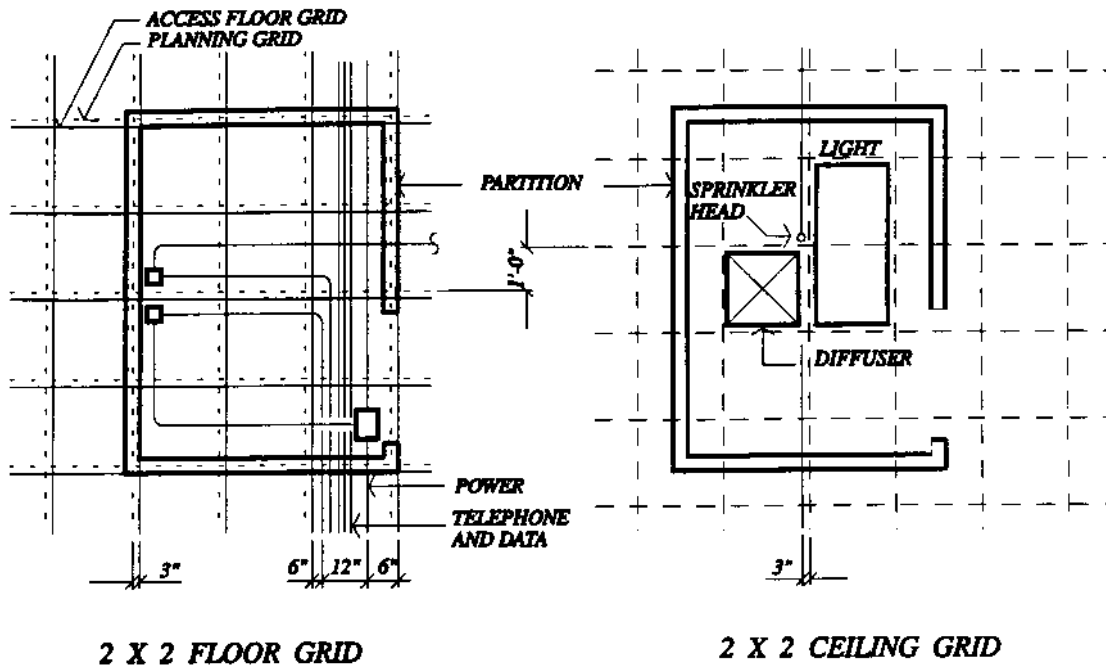

Figure 6-1  
**Floor and Ceiling Grid**

The centerlines of walls and ceiling height partitions always fall on the planning grid. Underfloor utilities - power, telephone and data - are always offset 50 percent of the grid line spacing. In all cases where raised access flooring is used, the pedestals of the access floor are offset from the planning grid by 75 mm in both directions.

The ceiling grid is offset from the planning grid by 50 percent of the grid spacing in both directions, so that the tops of walls never fall on the ceiling grid. This allows for more choices in placing ceiling elements, such as lights and diffusers.

Lights are always placed within the framing of the ceiling, whether lay-in fixtures, recessed down lighting or pendant fixtures are used.

**Horizontal Distribution of Power and Communications.** It is envisioned that power, data and telephone cables will be grouped together. In buildings with access flooring, power circuits should be provided via conduit, modular wire distribution boxes and modular wire cable sets to flush floor receptacles. Communication cables can be laid exposed directly on the slab and grouped together in rows 3 600 mm on center. See Figure 6-2.

In buildings without raised access floor, two other options exist for delivering power and communications services to the office floor: Cellular floor ducts or floor ducts encased in concrete. See Figures 6-3 and 6-4. When either of these delivery methods are used, ducts must be spaced 1 800 mm on center with presets for outlets at 600 mm on center.

The placement of outlets in walls or in the partitions of systems furniture is highly undesirable because of the difficulty it creates for future reconfiguration of the office space.

This is true for both closed office and open plan concepts. Light switches likewise should be located on columns and the walls of fixed core elements, to the maximum extent possible.

Flat conductors, poke-through or power poles are not to be used in new construction.

These criteria apply to all occupiable area or net usable space in a GSA building but not to public spaces or support spaces, which can be considered fixed elements and are not subject to frequent changes.

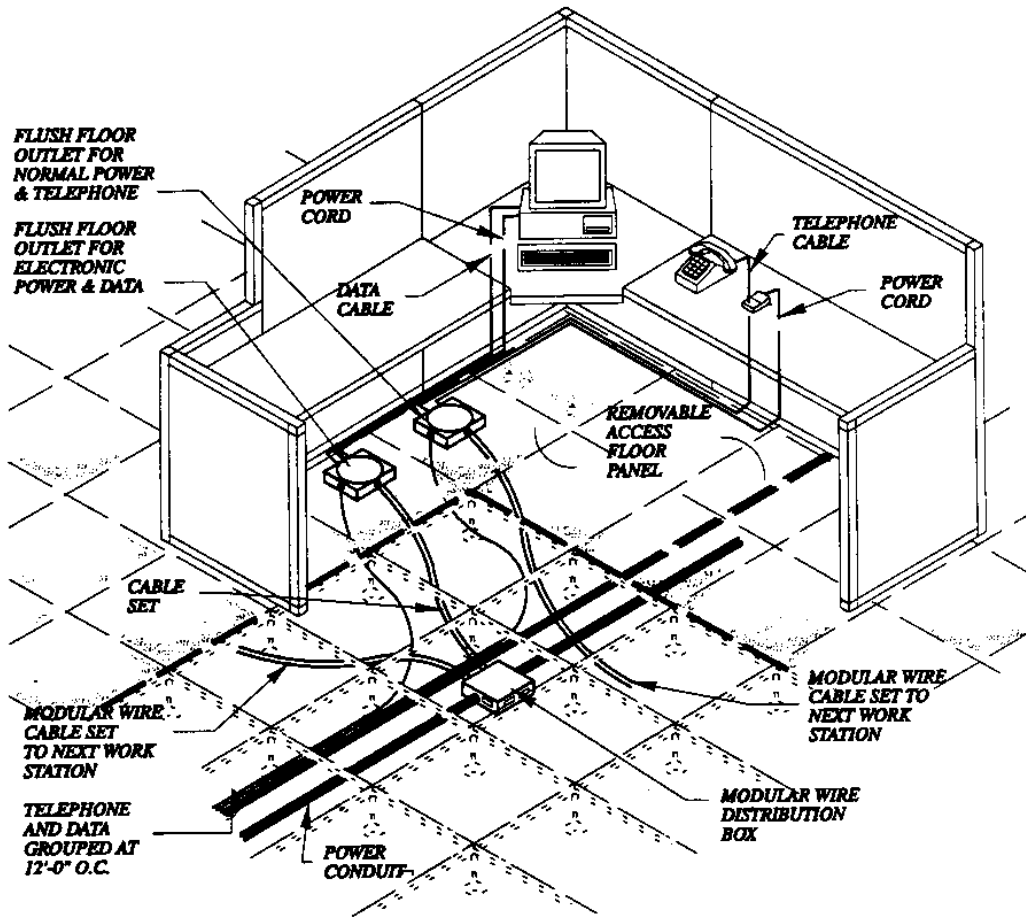

Figure 6-2  
Raised Access Floor Delivery

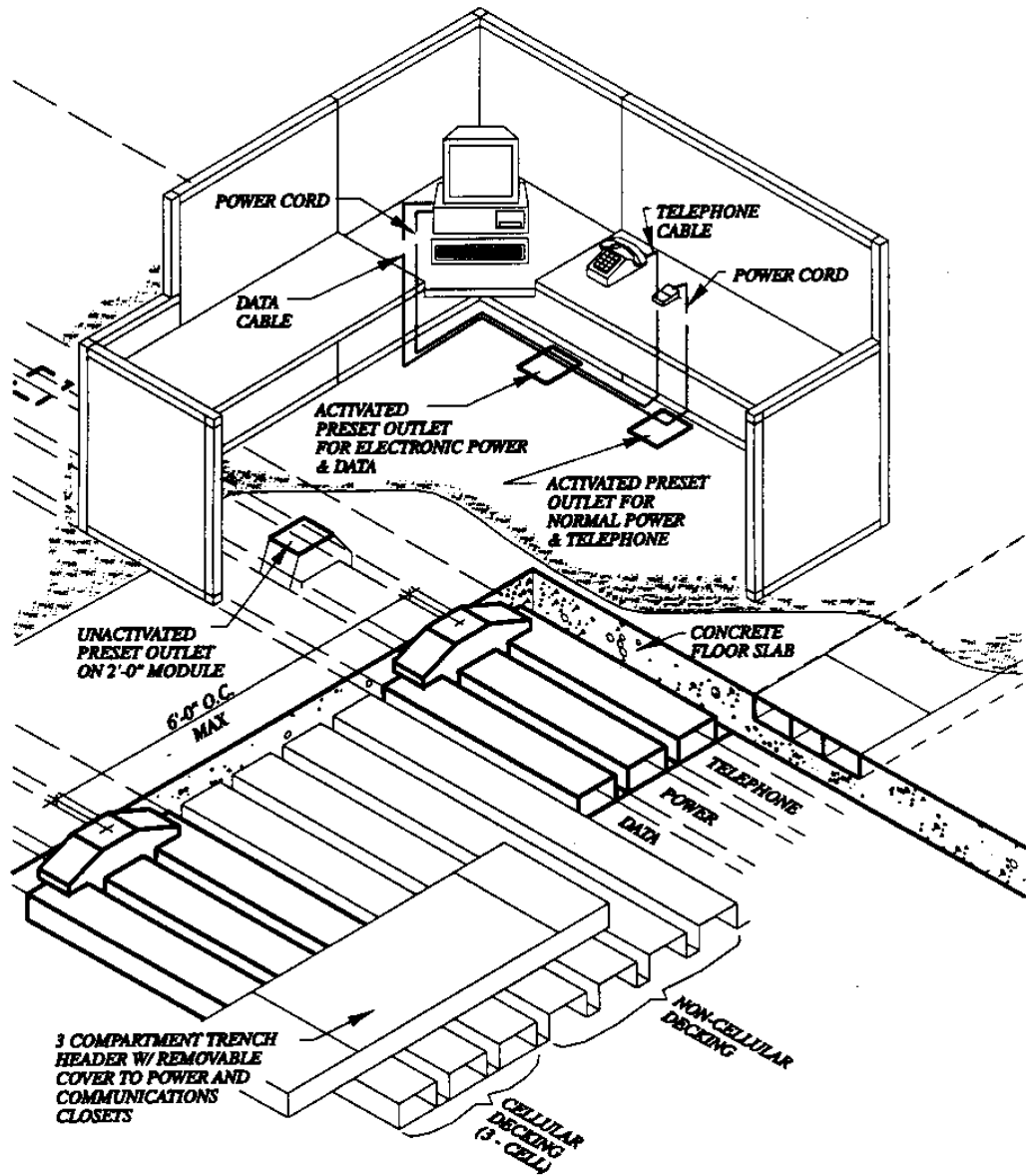

Figure 6-3  
Cellular Floor Duct Delivery

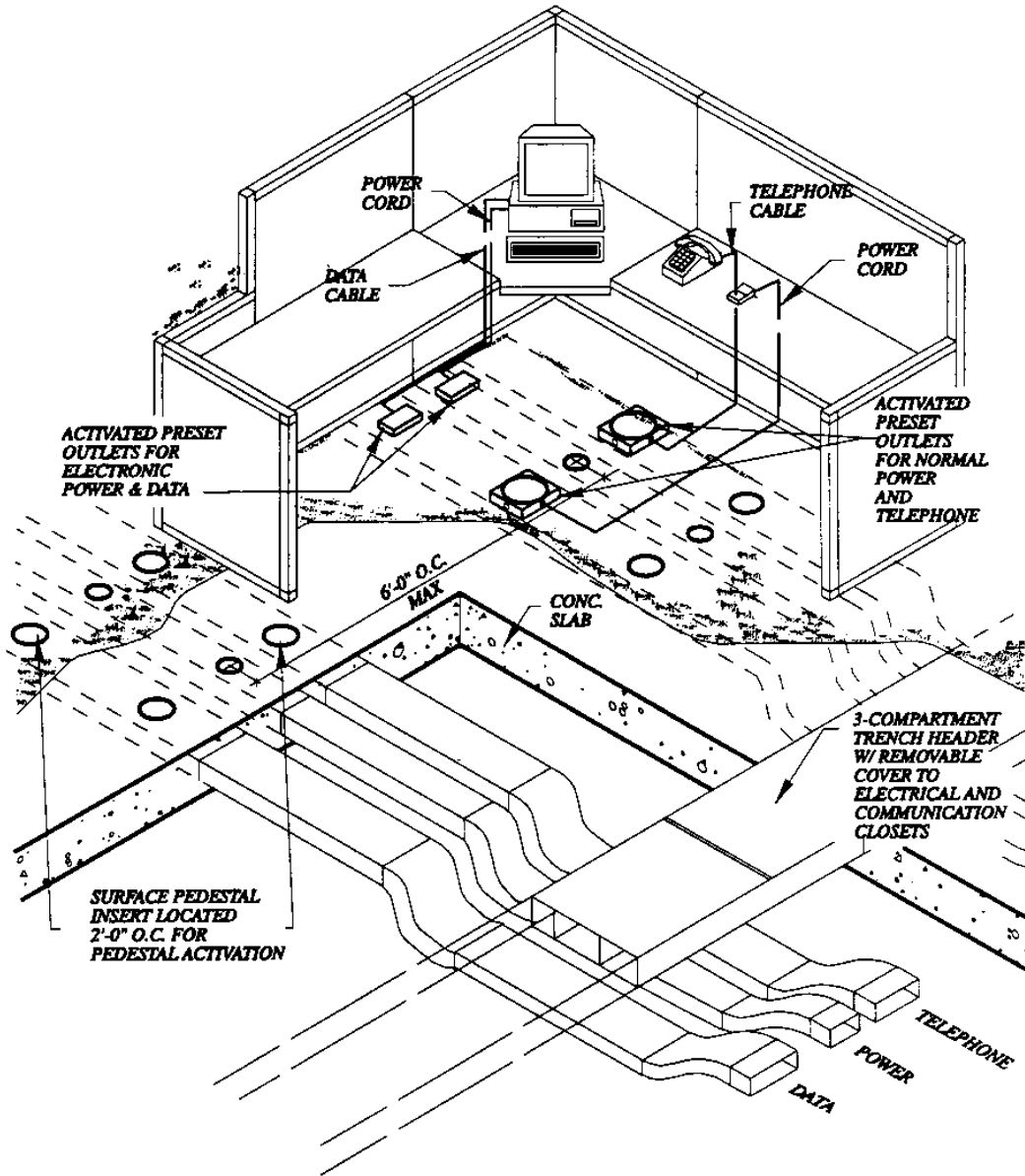

Figure 6-4  
Underfloor Duct Encased in Concrete

**Vertical Zoning of Floor-to-Floor Space.** Floor and ceiling spaces must be laid out to provide distinct zones for the placement of different utilities. The floor zone, usually the space under a raised access floor, is reserved for power, telephone and data cabling.

The ceiling space should be layered, with the sprinkler piping zone near the underside of the structure, or possibly through it, if steel beams are used, the HVAC duct zone in the middle and the lighting zone immediately above the ceiling level.

The depth of the ceiling and floor space must be determined early in the design, in order to arrive at the floor-to-floor height of the building. It needs to be based on preliminary estimates of systems designs. Enough space must be left between the HVAC and lighting zones to accommodate future lighting moves and changes without moving other components.

The underfloor zone should be as deep as the sum of all the required cross-overs plus 50 mm for leeway. The minimum total depth, including the 50 mm deep floor panels, is 150 mm.

Figure 6-5  
**[Reserved]**

**Vertical Distribution.** Risers for normal power, emergency power and communications should be combined with other core elements to form compact groups and maximize usable floor space. The number and size of risers will depend on the systems chosen, but future flexibility should be an important criterion in the vertical layout as well. Electrical closets should have two capped spare sleeves through the structural floor for future flexibility. Communications closets should also have two capped spare sleeves in each closet.

## **General Design Criteria**

**Conservation.** Code requirements for energy conservation are detailed in Chapter 1: *General Requirements, Codes and Standards, Mandatory Design Standards, Energy Conservation Standards*. The largest single factor in the energy consumption of a building is lighting. The overall efficiency of the lighting system depends both on the individual components and on the interaction of components in a system. A good controls strategy that eliminates lighting in unoccupied spaces and reduces it where daylighting is available can contribute significantly to energy conservation. The best way to institute such controls is through a Building Automation System (BAS). See Section on *Lighting, Lighting Controls* in this chapter for further discussion. Designers should check with local power companies and include technologies that qualify for rebates.

**Visual Impact.** Options regarding the location and selection of electrical work that will have a visual impact on the interior and exterior of the building should be closely coordinated with the architectural design. This includes colors and finishes of lights, outlets and switches.

**Equipment Grounding Conductor.** All low voltage power distribution systems should be supplemented with a separate, green insulated equipment grounding conductor.

**Lightning Protection.** Lightning protection should be evaluated in accordance with NFPA 78. Buildings in the "moderate to severe" category of exposure and higher should be equipped with a UL listed lightning protection system. The system should be carefully designed to ensure that static discharges are provided with an adequate path to ground. Surge arresters on the main electrical service should also be considered.

**Cathodic Protection.** The need for corrosion protection for conduits and for all other underground piping and buried metals on the project must be evaluated through soil resistivity and pH testing. Testing for soils resistivity is part of the Geotechnical Report. See GSA document *Submission Requirements for Design and Construction (PBS-PQ280)*. Cathodic protection should be designed by a qualified specialist.



**Operations and Maintenance Considerations.** Generally, Federal buildings are open for operation from 7:00 a.m. until 6:00 p.m. Monday through Friday, except for Federal holidays. In isolated cases, buildings or parts of buildings may need to operate on 24-hour schedules.

Some GSA buildings may be attended by maintenance or security personnel for 24 hours a day, but this is not the norm. Many Federal buildings are supervised from a remote central station at night.

Each GSA building has a Federal manager and core staff. Most of the actual maintenance work is let to private contractors, particularly in the case of larger buildings. Contract maintenance services vary greatly in scope and sophistication, from employment of individuals for specific tasks to full service contracts that include incentive clauses for savings in building operating costs.

Operating conditions will have a large impact on the choice of the BAS and on equipment maintenance considerations. The engineer is encouraged, therefore, to evaluate the planned maintenance provisions for each project.

## **Electrical Load Analysis**

In establishing electrical loads for Federal buildings it is important to look beyond the immediate requirements stated in the project program. Even if floor layout remains unchanged, equipment loads may become denser. Future moves and changes have the effect of redistributing electrical loads. The minimum connected receptacle loads indicated in Table 6-1 combined with other building loads multiplied by appropriate demand factors, and with spare capacity added, should be used for obtaining the overall electrical load of the building. If the load requirements stated in the program are higher, the program requirements must, of course, be satisfied.

Table 6-1  
**Minimum Connected Receptacle Load**

Type of occupiable area	Minimum connected receptacle load Load per square m <sup>2</sup>
<b>Normal systems</b>	
Office	
Non-workstation areas such as public and storage	14 V+A/m <sup>2</sup>
<b>Electronic systems</b>	10 V+A/m <sup>2</sup>
Office	13 V+A/m <sup>2</sup>
Computer rooms	700 V+A/m <sup>2</sup>

NOTE: Normal and electronic equipment systems are as shown on Figure 6-6

**Standards for Sizing Equipment and Systems.** To ensure maximum flexibility for future systems changes, the electrical system must be sized as follows: panel boards for branch circuits must be sized with 50 percent spare ampacity, distribution panels with 35 percent spare ampacity and main switchgear with 25 percent spare ampacity.

## Utility Coordination and Site Considerations

**Power Company Coordination.** See Chapter 2: *Site Planning and Landscape Design, Site Utilities, Utilities Services.*

These data must be established prior to initial system design. Electrical load estimates need to be prepared in conjunction with utility company discussions to establish the capacity of the new electrical services.

The service entrance location for commercial electrical power should be determined concurrently with the development of conceptual design. Space planning documents and standards for equipment furnished by utility companies should be incorporated into the concept design.

Locations for transformers, vaults, meters and other utility items must be coordinated with the architectural design to avoid detracting from the building's appearance.

**Site Considerations.** The routing of site utilities and location of manholes should be determined early in the design process.

It is desirable to have the utility company furnish power at the main utilization voltage, i.e., 480Y/277V or 120/208V (for small buildings). GSA prefers that the utility company own and maintain the transformers.

In the case of large buildings or buildings with large footprints, it may be necessary to have more than one service. In large office buildings and in campus situations, it may also be necessary to distribute medium voltage power. If available, medium voltage, up to 15KV, should be used for primary power distribution to substations.

**Communications Service Coordination.** All communications systems within the building are designed, installed and operated under the management of the Information Resources Management Service (IRMS). IRMS contracts for service to GSA buildings. The engineers involved in the building design must coordinate their work with IRMS not directly with a telephone company. IRMS will provide space requirements for telephone switch or PABX rooms and furnish information on any other design requirements.

## **Site Distribution**

Exterior distribution systems must be either direct buried conduit or concrete encased conduit systems. Cable selection should be based on all aspects of cable operation and the installation environment, including corrosion, ambient heat, rodent attack, pulling tensions and potential mechanical abuse.

**Direct Buried Conduit.** Direct buried PVC, coated intermediate metallic conduit (IMC) or rigid galvanized steel (RGS) is appropriate for the distribution of branch circuits. Direct buried cable should not be used.

Direct Buried Conduit. Direct buried PVC, coated intermediate metallic conduit (IMC) or rigid galvanized steel (RGS) is appropriate for the distribution of branch circuits. Direct buried cable should not be used.

**Concrete-Encased Ductbank.** Concrete-encased ductbanks should be used where many circuits follow the same route, for runs under permanent hard pavements and where service reliability is paramount, such as service entrances.

Duct line routes should be selected to balance maximum flexibility with minimum cost and to avoid foundations of other buildings and other structures. Ducts should be provided with a cover of at least 600 mm. Ductbanks under railroads should be reinforced. Ducts should slope 1:25 toward manholes. Changes in direction should be by sweeps with a radius of 7.5 m or more. Stub-ups into electrical equipment may be installed with manufactured elbows.

Where it is necessary to run communication cables alongside power cables, two separate systems must be provided with separate manhole compartments. The same holds true for normal and emergency power cables. Ductbanks should be spaced at least 300 mm apart.

Electrical and communication ducts should be kept clear of all other underground utilities, especially high temperature water or steam.

**Duct Sizes.** Ducts should be sized as required for the number and size of cables. Inner ducts must be provided inside communication ducts wherever fiber optic cables will be used. A sufficient number of spare ducts should be included for planned future expansion; in addition, a minimum of 25 percent spare ducts must be provided for unknown future expansion.

**Manholes.** Manholes should be spaced no farther than 150 m apart for straight runs. The distance between the service entrance and the first manhole should not exceed 30 m. Double manholes should be used where electric power and communication lines follow the same route. Separate manholes should be provided for low and medium voltage systems. Manholes should have clear interior dimensions of no less than 1 800 mm in depth, 1 800 mm in length, and 1 800 mm in width with an access opening at the top of not less than 750 mm in diameter. Manholes must have a minimum wall space of 1 800 mm on all sides where splices are to be racked.

*Stubs.* A set of spare stubs should be provided so that the manhole wall will not need to be disturbed when a future extension is made. Stubs for communications manholes must be coordinated with IRMS.

Smaller manholes may be used for low voltage feeders, branch circuits or communications circuits. They should be not less than 1 200 mm in depth, 1 200 mm in length, and 1 200 mm in width with a standard manhole cover and sump of the same type provided for manholes. Generally, at least four racks should be installed. Where more than two splices occur, a manhole may be more appropriate. Where splicing or pulling of low-voltage or communication cables requires an access point, but the volume provided by a smaller manhole is unnecessary, pullboxes may be more suitable for the installation.

## **Primary Distribution**

The selection of a primary distribution system, i.e., radial, loop, primary selective, secondary selective, network, etc., should be evaluated on a case by case basis, with consideration given first to safety, then to cost and reliability. Generally, radial or loop systems are preferred.

The primary distribution system design should be based on the estimated demand load plus 25 percent spare capacity.

**Medium Voltage Switchgear.** When required, medium voltage service switchgear may be provided with either air, vacuum or SF6 circuit breakers or fused air interrupter switches. Provide voltmeter, ammeter and watt-hour meter with demand register. Meters should be pulse type for connection to the BAS.

**Conductors.** Conductors should be insulated with cross linked polyethylene (XLP) or ethylene propylene rubber (EPR). 133 percent insulation should be provided. Conductor size should not exceed 500 MCM ~ 255 mm<sup>2</sup>.

**Spot Network Transformers.** In cases where reliability is an absolutely critical concern - the IRS office that processes refund checks, for example - network transformers should be considered. In large cities, where load densities are very high, utility companies may choose to supply power through network transformers. If so, these systems should be utility owned and maintained.

Spot Network Transformers. In cases where reliability is an absolutely critical concern - the IRS office that processes refund checks, for example - network transformers should be considered. In large cities, where load densities are very high, utility companies may choose to supply power through network transformers. If so, these systems should be utility owned and maintained.

**Double-ended Substations.** If reliability is critical and spot networks cannot be provided by the utility, double-ended substations should be used. Transformers may be equipped with fans to increase the rated capacity by 33 percent. The sum of the estimated demand load of both ends of the substation must not exceed the rating of either transformer, and it must not exceed 133 percent of the fan cooling rating. All double-ended substations should be equipped with two secondary main breakers and one tie breaker set up for open transition automatic transfer.

**Transformers.** Substation transformers must be dry type with epoxy resin cast coils. Liquid filled transformers may be used outdoors. Substations should be located at least 30 m from communications frame equipment to avoid radio frequency interference. Provide lightning arrestors on the primary side of all transformers. Consider surge suppression on the secondary and/or downstream busses.

Transformers located in underground vaults must not be positioned directly adjacent to or beneath an exit way.

## **Secondary Distribution**

**Main Switchboards.** 208V and 480V service switchboards as well as substation secondary switchboards should be provided with a single main service disconnect switch. This main switch should be molded case, insulated case or power air circuit breaker, individually mounted, draw-out type. Insulated case and power air circuit breakers should be electrically operated.

The meter section should contain a voltmeter, ammeter and watt-hour meter with demand register. Meters should be pulse type for connection to the BAS.

Feeder devices of switchboards 2,000 AMPS and larger should be molded case, insulated case or power air circuit breakers, individually mounted, draw-out type and electrically operated where applicable. Feeder devices of switchboards 2,000 AMPS and smaller may be group mounted, molded case circuit breakers.

Switchboards should be front and rear accessible. In smaller switchboards, front access only is acceptable if space is limited.

**Grounding.** Power distribution system grounding must be in accordance with Article 250 of the National Electrical Code.

**Ground Sources.** The ground source for the electrical power system must have a maximum resistance to ground of 5 ohms, except in small buildings (less than 5000 m<sup>2</sup>) that have only minimal communications systems. Grounding systems for these buildings may have a resistance up to 10 ohms. The grounding design must be based on a soils resistivity test and ground resistivity calculations. Below grade connections should be exothermically welded.

A wall-mounted, 6 mm by 50 mm copper ground bus should be provided in each electrical room housing medium voltage switchgear or substations. The ground bus should be located in the rear access aisle of the room and should extend at least 1 m. It should be interconnected with the ground electrode and ground bus in the switchgear or switchboard.



**Submetering.** Electric power meters must be provided on the services to all spaces planned to be outleased, to all computer rooms and to the parking garage, if any.

**Power Factor Correction.** If the utility rate structure has a power factor penalty, non-PCB centralized automatic power factor capacitors should be connected at the main electrical service on the load side of the utility metering. Power factor capacitors should be designed to automatically correct a lagging power factor to a value that will avoid penalty charges. Switching circuits should be specifically designed to prevent electrical noise from entering the electrical power distribution system.

**Motor Control Centers.** Grouped motor controls should be used where more than six starters are required in an equipment room. Motor control center construction should be NEMA Class I, Type B with magnetic starters and either circuit breakers or fuses. Minimum starter size should be size 1 in motor control centers. Each starter should have three overload relays. Control circuit voltage should be 120V connected ahead of each starter via control transformer as required.

In the design of motor control centers on emergency power, time delay relays should be considered to reduce starting KV+A on the generator.

**Elevator Power.** Elevators should be powered from a shunt trip circuit breaker located in the elevator machine rooms. Electrical design standards in elevator standard ANSI A17.1 must be followed.

## Secondary Distribution Systems

Secondary electrical power distribution systems in Federal buildings are classified as normal, emergency and uninterruptible. Normal power serves the general power and lighting loads in the building. Emergency power is distributed to life safety and critical loads. Uninterruptible power is required for critical loads which cannot be interrupted.

In typical GSA office buildings it is recommended that 120/208V normal power be subdivided to isolate the office electronic equipment load. Figure 6-6 shows a typical

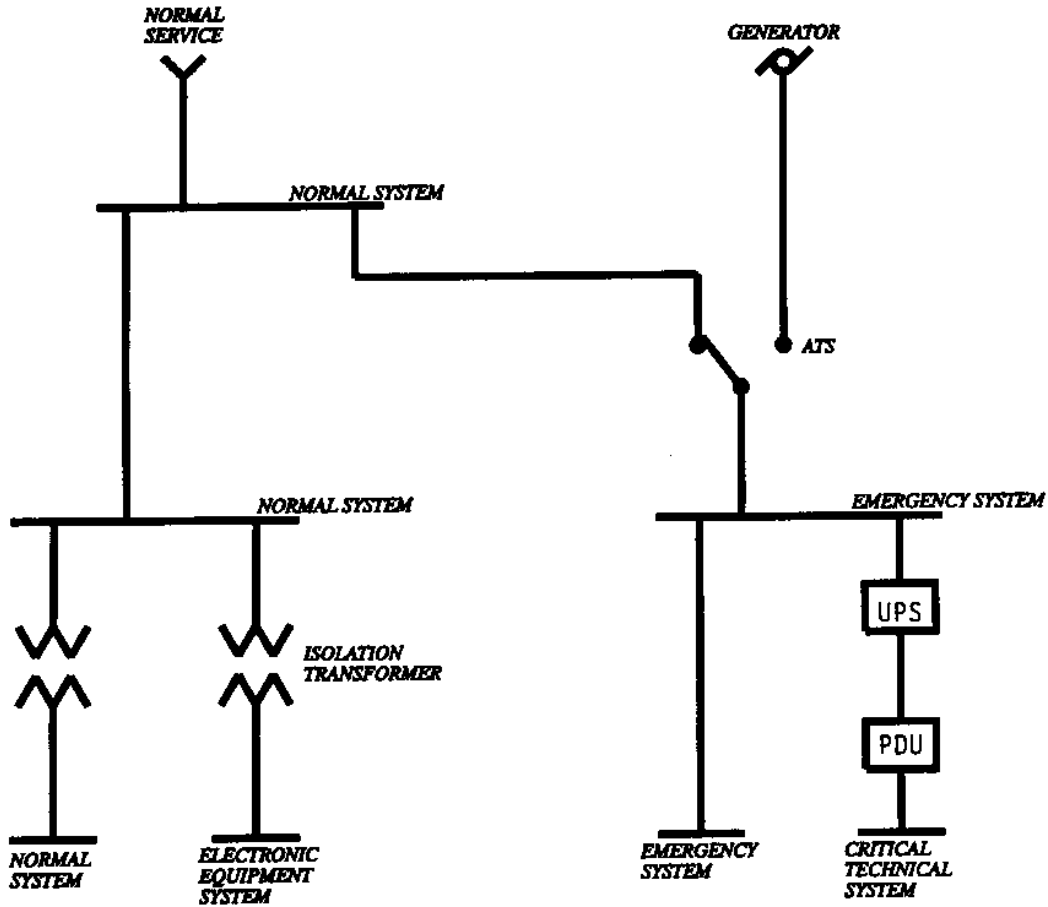

power distribution scheme.

Figure 6-6  
Simplified Power Distribution Diagram

**Bus Duct.** Where plug-in bus duct is used, it should have an integral ground bus, sized at 50 percent of the phase bus to serve as the equipment grounding conductor.

**Conductors.** Aluminum or copper conductors are acceptable for motor windings, transformer windings, switchgear bussing, switchboard bussing and bus duct, where the conductor is purchased as part of the equipment. Aluminum or copper conductors may be used for cables; however, aluminum conductors shall not be used for branch circuits.

**Power Distribution Panels.** Power distribution panelboards should be circuit breaker type.

**Lighting and Receptacle Panelboards.** Lighting and receptacle panelboards should be circuit breaker type.

Lighting panel boards should have 5 percent spare circuit breakers (minimum 3 - 20/1) plus 20 percent space (minimum 6 poles) for future circuit breakers.

Receptacle panelboards should have 10 percent spare circuit breakers (minimum 6 -20/1) plus 15 percent space (minimum 6 poles). For initial planning purposes, the number of receptacle circuits may be estimated by assuming 23 m<sup>2</sup> per circuit.

All panelboards must be located in closets. In circumstances where horizontal runs would become excessive and another riser is not warranted, shallow closets, at least 450 mm deep, may be used for additional panelboards.

**Panelboards Serving Electronic Equipment.** Electronic equipment panelboards serving personal computers, computer terminals or dedicated work stations should have an isolated ground bus. The service to the electronic panelboard should be supplied from an isolation transformer. Equipment should be sized with consideration given to higher harmonic currents in the neutral wire. For initial planning purposes, the number of receptacle circuits may be estimated by assuming 19 m<sup>2</sup> per circuit.

## **Wiring Devices**

In GSA buildings, general wiring devices must be specification grade. Emergency receptacles must be red. Isolated grounding receptacles must be orange. Special purpose receptacles must be brown. The color of standard receptacles and switches should be coordinated with the architectural color scheme; for example, white, not ivory, devices should be used if walls are white or light gray.

Building standard receptacle must be duplex, specification grade NEMA 5-20R. Special purpose receptacles should be provided as required. Device plates should be plastic, colored to match the receptacles.

### **Placement of Receptacles**

**Corridors.** Receptacles in corridors should be located 15 m on center and 7.5 m from corridor ends.

**Office Space.** Receptacles for housekeeping should be placed in exterior walls and walls around permanent cores or corridors. Except for these, placement of receptacles in walls should be avoided to the maximum extent possible. See Chapter 3: *Architectural and Interior Design, Building Planning, Planning Module, Floor-to-Floor Heights and Vertical Building Zoning, and Space Planning, Office Space, Utility Placement.*

*Raised Access Floor.* All wiring beneath a raised access floor should be routed in metal conduit or cable to underfloor distribution boxes. One distribution box per bay is recommended (see section *Placing Electrical Systems in Buildings, Horizontal Distribution of Power and Communications*, Figure 6-2 of this chapter). Flush mounted access floor service boxes should be attached to the underfloor distribution boxes by means of a plug-in modular wiring system to facilitate easy relocation.

*Cellular Floor Duct.* When cellular floor duct delivery is used, it should be configured as indicated in section *Placing Electrical Systems in Buildings, Horizontal Distribution of Power and Communications*, Figure 6-3 of this chapter. The distance between horizontal duct runs is 1 800 mm. Presets should be located every 600 mm in each run.

*Floor Duct Encased in Concrete.* When concrete encased floor duct delivery is used, it should be configured as indicated in section *Placing Electrical Systems in Buildings, Horizontal Distribution of Power and Communications*, Figure 6-4 of this chapter. The distance between horizontal duct runs is 1 800 mm. Inserts should be located every 600 mm in each run.

*Number of Receptacles.* For initial planning purposes, assume that office space uses systems furniture with a density of two work stations for every 9 m<sup>2</sup>. Electrical systems should be designed to allow two duplex outlets for electronic equipment power and two duplex outlets for normal power per work station.

**Conference Rooms.** Conference rooms should be served in the same fashion as general office space.

**Maintenance Shops.** Maintenance shops require plugmold strips above work benches with outlets 450 mm on center.

**Electrical and Communications Closets.** Electrical closets require one emergency power receptacle; communications closets require two. If uninterruptible power is required in communications closets, it will be furnished as part of the communications system.

**Main Mechanical and Electrical Rooms.** Main mechanical and electrical equipment rooms should each have one emergency power receptacle.

**Toilet Rooms.** Each toilet room should have one GFI receptacle at the vanity.

## **Emergency Power Systems**

All facilities must have an emergency power system for life safety as required by code. It must be designed in accordance with NFPA 110, Emergency and Standby Power Systems.

### **Batteries**

Self contained battery units may be used for individual light fixtures in buildings where an emergency generator is not required for other systems. When batteries are used to supply lighting, they should be capable of supplying emergency power for 1 1/2 hours.

Fire alarm and security systems must be provided with their own battery back-up.

### **Generator Systems**

The system should consist of a central engine generator and a separate distribution system with automatic transfer switch(es), distribution panels, and 480V/277V lighting panels with dry-type transformers feeding 208V/120V panels as required.

**Service Conditions.** If the unit is to be installed outdoors, it should be provided with a suitable enclosure and have provisions to ensure reliable starting in cold weather. Diesels are particularly susceptible to slow starting when cold; however, starting aids such as jacket-water heaters can be specified to improve reliable starting capability.

When installed at high altitudes or in higher-than-rated ambient temperatures, the unit must be derated in accordance with manufacturers' recommendations. Operation of starting batteries and battery chargers must also be considered in sizing calculations. In humid locations heaters can reduce moisture collection in the generator windings. Silencers are required for all generators. Acoustical treatment of the generator room should also be considered.

Generators should be located at least 100 feet from communications frame equipment to avoid radio frequency interference. See Chapter 3: *Architectural and Interior Design, Space Planning, Building Support Spaces, Mechanical and Electrical Rooms, Emergency Generator Rooms* for additional generator room requirements.

Radiators should be unit mounted if possible. If ventilation is restricted in indoor applications, remote installation is acceptable. Heat recovery and load shedding should not be considered.

**Capacity.** The engine generator should be sized to approximately 110 percent of design load; ideally it should run at 50 percent to 80 percent of its rated capacity after the effect of the inrush current declines. When sizing the generator, consider the inrush current of the motors that are automatically started simultaneously. The initial voltage drop on generator output due to starting currents of loads must not exceed 15 percent.

**Emergency Power Loads.** Emergency power should be provided for the following functions:

- Egress and exit lighting.
- Fire alarm system.
- Generator auxiliaries.
- Smoke control systems (if required by code)<sup>1</sup>.
- Fire pump.
- Lighting<sup>2</sup>.
- Telephone switch.
- Security systems.
- Mechanical control systems.
- Building Automation System.
- Elevators (one per bank)<sup>1</sup>.
- Sump pumps.
- Sewage ejector pumps.
- Exhaust fans removing toxic, explosive or flammable fumes.
- Uninterruptible power systems serving computer rooms<sup>1</sup>.
- Air conditioning systems for computer and UPS rooms<sup>1</sup>.
- Exhaust fan in UPS battery rooms.
- Power and lighting for Fire Control Center and Security Control Center.

---

Notes: <sup>1</sup> Evaluate on a case by case basis.

<sup>2</sup> As noted in the Section: *Lighting Criteria for Building Spaces* of this chapter.

**Distribution System.** The distribution system should be designed so that emergency and auxiliary power sources cannot backfeed energy into the de-energized normal voltage systems under normal, emergency or failure conditions.

**Generator Derangement Alarms.** Generator derangement alarms must be provided in the generator room. All malfunctions should be transmitted to the BAS. In buildings without BAS, a generator alarm annunciator should be located in the lobby next to the fire alarm panel.

**Automatic Transfer Switches.** Automatic transfer switches serving motor loads should be dual motor operated (adjustable time delay neutral position) or have in-phase monitor (transfer when normal and emergency voltages are in phase) to reduce possible motor damage caused by out of phase transfer. They may also have pre-transfer contacts to signal time delay relays in the emergency motor control centers.

In order to reduce possible nuisance tripping of ground fault relays, automatic transfer switches serving 3-phase, 4-wire loads should have 4-pole contacts with an overlapping neutral.

Automatic transfer switches should include a bypass isolation switch that allows manual bypass of the normal or emergency source to insure continued power to emergency circuits in the event of a switch failure or required maintenance.

**Load Bank.** Generally, generators should be run with the actual load connected. In selected applications where critical loads cannot tolerate a momentary outage, load banks may be considered.

**Paralleling.** For major computer centers and other critical facilities, generator paralleling should be considered.

**Fuel Distribution System.** See *Chapter 5: Mechanical Engineering, Heating Systems, Boilers and Heat Exchangers*, for information on fuel oil piping and underground fuel oil tanks.



## Uninterruptible Power Systems

In some facilities computer room back-up systems may be designed by the tenant agency. If this is the case, shell space and utility rough-ins should be provided. In facilities where UPS systems are to be provided as part of the building construction, they should be designed as described in this section. All UPS systems are considered to be above standard for GSA space.

An uninterruptible power supply (UPS) consists of one or more UPS modules, batteries and accessories. The UPS isolates critical technical loads from normal and emergency power sources, supplies "clean" power to these loads and, in the event of a power interruption, provides continuous power from its batteries for a specified period (normally 15 minutes, unless a longer period is required by the project program). When serving computer loads, the UPS must be properly grounded to preclude setting up ground loops through the protected equipment.

Requirements for UPS systems must be evaluated on a case by case basis. If UPS is required, it may or may not require generator back-up. When generator back-up is unnecessary, sufficient battery capacity should be provided to allow for an orderly shut-down.

**Solid-State versus Rotary UPS.** Either solid-state or rotary UPS may be selected, based on project requirements.

Consider rotary UPS to serve loads requiring frequency changes, loads which serve high in-rush loads, or facilities which have significant non-linear loads.

Solid-state UPS should be provided with an input filter or transformer to reduce harmonic currents back into the distribution system.

Consider the use of solid-state surge protection to protect both the UPS and downstream equipment when in by-pass.

**Electrical Service and Bypass Circuits.** Three separate electrical services should be provided: one to the UPS rectifier circuit, one to the inverter bypass circuit and one to a maintenance by-pass circuit.

**Electrical Service Size.** A UPS system should be sized with 25 percent spare capacity.

**Critical Technical Loads.** The nature, size, and locations of critical loads to be supplied by the UPS will be provided in the program. The UPS system should serve critical loads only. Non-critical loads should be served by separate distribution systems supplied from either the normal or electronic distribution system. Section *Site Distribution, Secondary Distribution, Secondary Distribution Systems* Figure 6-6 of this chapter shows the integration of UPS into the building power distribution system.

**Emergency Electrical Power Source Requirements.** When the UPS is running on emergency power, the current to recharge the UPS batteries should be limited. This limited battery charging load should be added when sizing the emergency generator.

If the UPS system is backed up by a generator to provide for continuous operation, then the generator must also provide power to all necessary auxiliary equipment, i.e., the lighting, ventilation, and air conditioning supplying the UPS and serving the critical technical area.

**System Status and Control Panel.** The UPS should include all instruments and controls for proper system operation. The system status panel should have an appropriate audio/visual alarm to alert operators of potential problems. It should include the following monitoring and alarm functions: system on, system bypassed, system fault, out of phase utility fault, closed generator circuit breaker. It should have an audible alarm and alarm silencer button. Since UPS equipment rooms are usually unattended, an additional remote system status panel must be provided in the space served by the UPS. The alarms should also be transmitted to the BAS.

**UPS Environmental Status Panel.** The environmental status of the UPS and battery rooms should also be monitored by a panel in the computer center and by the BAS.

**UPS and Battery Room Requirements.** Design the battery room in accordance with Article 480 of National Electrical Code. Provide emergency lighting in both spaces. Provide a telephone in or adjacent to the UPS room. See Chapter 3: *Architectural and Interior Design, Space Planning, Building Support Space, Mechanical and Electrical Rooms, Spaces for Uninterruptible Power Systems (UPS) and Batteries* for additional requirements for UPS and Battery Room.

**Battery Racks.** Provide 20-year life batteries. Racks should be two tier with bracing and connections to match seismic conditions of the site.

**Battery Cabling.** In laying out the battery room, consider that excessive cable lengths result in high voltage drop which could reduce the power available from the battery. Battery Cabling. In laying out the battery room, consider that excessive cable lengths result in high voltage drop which could reduce the power available from the battery.

**Acoustical Treatment.** Rotary and some static UPS may require acoustical treatment to reduce noise levels.

**Paralleling.** Provide paralleling for solid-state UPS of 500 kV+A and above and rotary UPS of 300 kV+A or greater.

**Redundancy.** The need for redundant equipment should be evaluated on a project basis. Redundancy should be provided if paralleling is used.

## **Computer Center Power Distribution**

In some GSA buildings the power distribution system for computer centers will be designed by the tenant agency. In that case utility rough-in should be provided under the construction contract. If distribution is to be provided under the building contract, it should be designed according to the criteria in this section.

**Power Distribution Units (PDU's).** PDU's with internal or remote isolation transformers and output panelboards should be provided in all computer centers.

**Non-linear Loads.** Non-linear loads generate harmonic currents that are reflected into the neutral service conductors. Engineers should exercise caution when designing circuits and selecting equipment to serve non-linear loads, such as automated data processing equipment in computer centers.

It is recommended to size neutrals at twice the size of the phase conductor. PDU's with internal or remote isolation transformers should also be derated for non-linear loads. The transformer rating must take the increased neutral size into account.

**Computer Center Grounding.** To prevent electrical noise from affecting computer system operation, a low frequency power system grounding and a high frequency signal reference grounding system should be provided. The design of the computer room grounding system should be discussed with the computer center staff.

*Low Frequency Power System Grounding.* The primary concern is to provide a safe, low frequency, single point grounding system which complies with Article 250 of the National Electrical Code. The single point ground must be established to ground the isolation transformer or its associated main service distribution panel.

A grounding conductor should be run from the PDU isolation transformer to the nearest effective earth grounding electrode as defined in Article 250 of the NEC. All circuits serving Automated Data Processing (ADP) equipment from a PDU should have grounding conductors equal in size to the phase conductors.

*High Frequency Power System Grounding.* In addition to the low frequency power system grounding, a high frequency signal reference grounding system for radio frequency noise is required (with the two systems bonded together at one point). A grid made up of 600 mm squares will provide an effective signal reference grounding system. The raised floor grid may be used if it has mechanically bolted stringers. Alternatively a grid can be constructed by laying a mesh (600 mm squares) of braided copper strap or 1.3 mm by 50 mm copper strip directly on the structural floor below the raised access floor. Data processing equipment should be connected to the reference grid by the most direct route with a braided copper strap.

**Common Mode Noise Reduction.** The reduction of common mode noise is particularly important for the proper operation of computer based, distributed microprocessor based systems, i.e., building automation systems, electronic security systems, card access control systems, and local area networks.

The following guidelines should be considered to reduce common mode noise:

- Avoid running unshielded metallic signal or data lines parallel to power feeders.
- Where metallic signal or data lines must be routed in noise prone environments, use shielded cables or install wiring in ferrous metal conduit or enclosed cable trays.
- Locate metallic signal or data lines and equipments at a safe distance from arc producing equipment such as line voltage regulators, transformers, battery chargers, motors, generators, and switching devices.
- Provide isolation transformers, electronic power distribution panelboards or power conditioners to serve critical electronics equipment loads.
- Provide isolated grounding service on dedicated circuits to critical data terminating or communicating equipments.
- Replace metallic data and signal conductors with fiber optic cables where practical.

**Emergency Power Off (EPO) Systems.** EPO pushbuttons should be provided in data processing centers at exits and at PDU's. Upon activation of push button or local fire alarm system, all power to the room and to the HVAC system for the room should be disconnected per National Electric Code, Article 645 and NFPA 75, Protection of ADP Equipment.

## Lighting

Lighting should be designed to enhance both the overall building architecture as well as the effect of individual spaces within the building.

### Interior Lighting

Consideration should be given to the options offered by direct lighting, indirect lighting, downlighting, uplighting and lighting from wall or floor-mounted fixtures.

**Illumination Levels.** For lighting levels for interior spaces see the values indicated in Table 6-2. For those areas not listed in the table, the IES Lighting Handbook may be used as a guide.

In office areas with system furniture, assume that undercabinet task lighting is used and provide general illumination of about 300 lx on the work surface. Ceiling lighting branch circuit capacity, however, should be sufficient to provide levels in Table 6-2 for occupancy changes.

**Energy Efficient Design.** Lighting design must comply with ASHRAE/IES 90.1 as modified by Appendix 6.A. Power allowances for normal system receptacles include task lighting as shown in Table 6-1. Lighting calculations should show the effect of both general and task lighting assuming that task lighting where it is used has compact fluorescent tubes.

Table 6-2  
**Interior Illumination Levels**

Area	Nominal Illumination Level in lux
<b>Office Space</b>	
Normal work station space, open or closed offices <sup>1</sup>	500
ADP Areas	500
Conference Rooms	300
Training Rooms	500
Internal Corridors	200
Auditoria	300
<b>Public Areas</b>	
Entrance Lobbies, Atria	200
Elevator Lobbies, Public Corridors	200
Ped. Tunnels and Bridges	200
Stairwells	200
<b>Support Spaces</b>	
Toilets	200
Staff Locker Rooms	200
Storage Rooms, Janitors' Closets	200
Electrical Rooms, Generator Rooms	200
Mechanical Rooms	200
Communications Rooms	200
Maintenance Shops	500
Loading Docks	200
Trash Rooms	200
<b>Specialty Areas</b>	
Dining Areas	300
Kitchens	500
Outleased Space	500
Physical Fitness Space	500
Child Care Centers	500
Structured Parking, General Space	50
Structured Parking, Intersections	100
Structured Parking, Entrances	500

<sup>1</sup> Level assumes a combination of task and ceiling lighting where systems furniture is used.



**Light Sources.** Generally, interior lighting should be fluorescent. Downlights should be compact fluorescent; high bay lighting should be high intensity discharge (HID) type. HID can also be an appropriate source for indirect lighting of high spaces. However, it should not be used in spaces where instantaneous control is important, such as conference rooms, auditoria or courtrooms.

Dimming can be accomplished with incandescent, fluorescent or HID fixtures, although HID and fluorescent dimmers should not be used where harmonics constitute a problem. Incandescent lighting should be used sparingly. It is appropriate where special architectural effects are desired.

### **General Lighting Fixture Criteria**

**Lighting Fixture Features.** Lighting fixtures and associated fittings should always be of standard commercial design. Custom designed fixtures should be avoided. They may only be used with express approval from GSA in cases where available standard units cannot fulfill the required function.

Offices and other areas using personal computers or other VDT systems should use indirect or diffuser-shielded tube-type ceiling fixtures. Diffusers or lenses should be non-combustible acrylic.

**Baseline Building Fixture.** The fixture to be used for baseline cost comparisons for office space is a 600 mm by 600 mm or 600 mm by 1 200 mm fixture utilizing T-8 or CFL lamps and electronic ballasts.

The number of fixture types in the building should be minimized.

**Fixture Ballasts.** Ballasts should have a sound rating of "A" for 430 MA lamps, "B" for 800 MA lamps and "C" for 1 500 MA lamps. Electronic ballasts should be used wherever possible.

## **Lighting Criteria for Building Spaces**

**Office Lighting.** Office lighting is generally fluorescent lighting. A lighting layout with a fairly even level of general illumination is desirable. Modular (plug-in) wiring for fluorescent lighting fixtures should be used for office areas to facilitate changes. In open office areas with systems furniture partitions, the coefficient of utilization must be reduced to account for the light obstruction and absorption of the partitions.

Task lighting will be used in situations, such as areas of systems furniture, where the general lighting level would be insufficient for the specific functions required.

**ADP Areas.** Generally, ADP areas should have the same lighting as offices. If the area contains special work stations for computer graphics, dimmable incandescent lighting may be required. If a large ADP area is segregated into areas of high and low personnel activity, switching should be used when areas are not being worked in.

**Conference Rooms and Training Rooms.** These spaces should have a combination of fluorescent and dimmable incandescent lighting.

**Lobbies, Atria, Tunnels and Public Corridors.** Special lighting design concepts are encouraged in these spaces. The lighting design should be an integral part of the architecture. Wall fixtures or combination wall and ceiling fixtures may be considered in corridors and tunnels to help break the monotony of a long, plain space.

**Mechanical and Electrical Spaces.** Lighting in equipment rooms or closets will be equipped with industrial type fluorescent fixtures. Care should be taken to locate light fixtures so that lighting is not obstructed by tall or suspended pieces of equipment.

**Dining Areas and Serveries.** Ample daylight is the illumination of choice in dining areas, assisted by fluorescent fixtures. Limited incandescent lighting for accents is acceptable.

**Character-Defining Spaces in Historic Structures.** Spaces that contribute to the character of a historic structure, as identified the HBPP, should be lighted in a manner that enhances their historic and architectural character. Maintenance and rehabilitation of historic lighting fixtures should be considered, and may be required in the HBPP. Care should be taken to avoid placing fixtures, switches, conduit, or other electrical facilities through character-defining architectural elements.

**Structured Parking.** Fixtures for parking areas may be fluorescent strip fixtures with wire guards or diffusers. Care must be taken in locating fixtures to maintain the required vehicle clearance. Enclosed fluorescent or high intensity discharge (HID) fixtures should be considered for above-grade parking structures.

**High Bay Lighting.** Lighting in shop, supply, or warehouse areas with ceilings above 1 800 mm should be color improved high pressure sodium. In areas where color rendition is known to be of particular importance, metal halide should be used.

**Supplemental Emergency Lighting.** Partial emergency powered lighting must also be provided in main mechanical, electrical and communications equipment rooms; UPS, battery and ADP rooms; security control centers; fire control centers and the room where the Building Automation System is located. Where CCTV cameras are used for security systems, emergency lighting should be provided at the task area.

### **Lighting Controls**

All lighting must be provided with manual, automatic, or programmable microprocessor lighting controls. The application of these controls and the controlled zones will depend on a number of space factors: frequency of use, available daylighting, normal and extended work hours and the use of open or closed office plans. All of these factors must be considered when establishing zones, zone controls and appropriate lighting control.

**Lighting Configuration Benefits.** An appropriate lighting configuration can benefit the Government; it reduces operating costs by permitting limited operation after working hours, takes advantage of natural light during the daytime working hours and facilitates the subdivision of spaces.

**Enclosed Space Lighting Controls.** Enclosed space lighting controls may include switches, multi-level switching, occupancy sensors, light level sensors or micro-processors. The lights can be zoned by space or multiple spaces. If microprocessor controls are used to turn off the lights, a local means of override should be provided to continue operations when required.

The following design guidance is provided for enclosed areas:

- Photoelectric sensors that reduce lighting levels in response to daylighting are recommended for small closed spaces with glazing.
- Occupancy sensors should be considered for small closed spaces without glazing.
- Microprocessor control, programmable controller or central computer control are recommended for multiple closed spaces or large zones.
- Touchtone telephone or manual override controls should be provided if microprocessor, programmable controller or central computer control is provided.

**Open Space Lighting Controls.** Open space lighting controls may include switches, multi-level switching, light level sensors for spaces adjacent to glazing and microprocessor controls for zones within the space. If microprocessor controls are used to turn off the lights, a local means of override should be provided to continue operations when required.

Large open space should be subdivided into zones of approximately 100 m<sup>2</sup> or one bay. The following guidelines are provided for open plan spaces:

- Controls should be located on core area walls, on permanent corridor walls or on columns.
- Remote control schemes and reductions from a programmable controller, microprocessor, and/or central computer should be considered.

**Occupancy Sensor Lighting Controls.** Infrared or ultrasonic sensors should be considered for small, enclosed office spaces and toilet areas. Each occupancy sensor should control no more than 12 fixtures. Each occupancy sensor should be marked by a label identifying the panel and circuit number. Occupancy sensors should not be used in open office areas, spaces housing heat producing equipment or corridors.

**Ambient Light Sensor Controls.** Photoelectric sensors should be considered for fixtures adjacent to glazed areas and for parking structures.

## **Exterior Lighting**

Exterior luminaires must comply with local zoning laws. Lighting levels for exterior spaces should be the values indicated by the IES Lighting Handbook. Flood lighting should only be provided if specified in the building program. Exterior lighting of a historic structure should be designed to blend with and support the existing architectural characteristics that contribute to the structure's character.

**Parking and Roadway Lighting.** Parking and roadway lighting should be HID and should not exceed a 10 to 1 maximum to minimum ratio and a 4 to 1 average to minimum ratio.

Parking lots should be designed with high efficiency, pole mounted luminaires. High pressure sodium lamps are preferred but consideration should be given to existing site illumination and the local environment. Emergency power is not required for parking lot lighting.

*Entrances.* Lighting fixtures should be provided at all entrances and exits of major structures.

*Loading Docks.* Exterior door lighting should be provided at loading docks. Fixtures for illumination of the interior of trailers should be provided at each truck position.

*Controls.* Exterior lighting circuits should be controlled by photocell and a time clock controller to include both all-night and part-night lighting circuits.

## Raceway System for Communications

Communications systems for all GSA buildings will meet the requirements of EIA/TIA Standard 569. Communications systems for all GSA buildings will be designed by IRMS and installed by IRMS or the tenant. Only the raceway system is part of the building design and construction. It consists of vaults, communications equipment room(s), closets, sleeves, ducts, conduits, raceways and outlets.

Since IRMS will manage the design of the communications systems, all criteria for routing and types of raceways must be obtained from IRMS.

**Communications Frame Room.** A communications frame room should be provided in every building. It must be sized to accommodate voice and data distribution and transmission equipment and support equipment with adequate equipment access clearances. IRMS will provide detailed information on the communications equipment. A 5 ohm (maximum) signal ground and an emergency power receptacle should be provided in the room. The electrical service should be sized to accommodate the largest commercial switch of the type designated by IRMS. See Chapter 3: *Architectural and Interior Design, Space Planning, Mechanical and Electrical Rooms* for additional information on frame room requirements.

**Communication Closets.** Communication closets should be sized to accommodate telephone terminal boards and broadband and narrowband data communications equipment, including cross-connects, lightwave terminal cabinets, and equipment racks with patch panels and concentrators. Communication and electrical closets should be located adjacent to each other. Communications closets must be stacked vertically. See Chapter 3: *Architectural and Interior Design, Building Planning, Placement of Core Elements and Distances, Communications Closets and Space Planning, Building Support Spaces, Mechanical and Electrical Rooms, Communications Closets* for additional information on communications closets.

## **Communications Raceways**

**Raised Access Floor.** The standard option for delivering communications services in Federal buildings is by laying the cable in a tray for main runs and then branching directly on the floor slab below the raised access flooring system. See Section on *Placing Electrical Systems in Buildings, Horizontal Distribution of Power and Communications* in this chapter.

**Above Ceiling Delivery.** Communications distribution in ceilings should be avoided and only used where no other alternative exists. Where necessary, communications cabling above ceilings must be run in cable tray and/or conduit.

**Communications Outlets.** Telephone and data outlets are to be located by IRMS; layout information will be provided to A/E's.



## Layout of Main Electrical Rooms

Separate electrical rooms may be provided for medium voltage and low voltage switchgear assemblies.

**Vertical Clearances.** Main electrical equipment rooms generally should have a clear height to the underside of the structure above of at least 3 000 mm to allow for a radius for conduit entering from the top. Where maintenance or equipment replacement requires the lifting of heavy parts, hoists should be installed.

**Horizontal Clearances.** Electrical equipment rooms should be planned with clear circulation aisles and adequate access to all equipment. Layout should be neat, and the equipment rooms should be easy to clean.

**Lighting.** Lighting in equipment rooms should be laid out so as not to interfere with equipment. Switched emergency lighting must be provided in main electrical rooms.

**Housekeeping Pads.** Housekeeping pads should be at least 75 mm larger than the mounted equipment on all sides.

**Operation and Maintenance Manuals.** Documentation on all building systems should be provided for the guidance of the building engineering staff. This should show the actual elements that have been installed, how they performed during testing, and how they operate as a system in the completed facility.

- The building staff should be provided with the following:
- Record drawings and specifications.
- Operating manuals with a schematic diagram, sequence of operation and system operating criteria for each system installed.
- Maintenance manuals with complete information for all major components in the facility.

**Posted Instructions.** Posted operating instructions are required for manually operated electrical systems. They should consist of simplified instructions and diagrams of equipment, controls and operation of the systems, including selector switches, main-tie-main transfers, ATS by-pass, UPS by-pass, etc.

Instructions should be framed and posted adjacent to the major equipment of the system.

## Alterations in Existing Buildings and Historic Structures

The goal of GSA's alteration projects is to approximate as well as possible the facilities standards described in this book for new projects. Renovation designs must satisfy the immediate occupancy needs but should also anticipate additional future changes. Remodeling should make building systems more flexible.

Alteration projects can occur at three basic scales: refurbishing of an area within a building, such as a floor or a suite; major renovation of an entire structure; and upgrade/restoration of historic structures.

In the first instance, the aim should be to satisfy the new requirements within the parameters and constraints of the existing systems. The smaller the area in comparison to the overall building, the less should changes to existing systems be attempted.

In the second case, the engineer has the opportunity to design major upgrades into the electrical and communications systems. The electrical and communications services can come close to systems that would be designed for a new building, within the obvious limits of available physical space and structural capacity.

Where a historic structure is to be altered, special documents will be provided by GSA to help guide the design of the alterations. The most important of these is the Historic Building Preservation Plan (HBPP) which identifies zones of architectural importance, specific character-defining elements that should be preserved, and standards to be employed. See Chapter 1: General Requirements, Applicability of the Facilities Standards, Types of Facilities, Historic Buildings.

The electrical systems in historic buildings often differ greatly from today's design and construction standards, and frequently these systems need to be upgraded substantially or completely rebuilt or replaced. The end result should be a building whose lighting and other electrical facilities support its modern use while retaining its historic and architectural character.

The end user requirements are an important part of the programming information for alteration projects. Close interaction between designers and users is essential during the programming and conceptual design phase to meet the users' needs without excessive construction costs. The general policies and standards that an administrator would give designers are usually not specific enough.

Alteration design requires ingenuity and imagination. It is inherently unsuited to rigid sets of rules. Each case is unique. The paragraphs that follow in this section should be viewed as guidelines and helpful hints to be used when appropriate and disregarded when not.

See Chapter 3: Architectural and Interior Design, Alterations in Existing Buildings and Historic Structures.

### **Evaluation of Existing Systems**

Every alteration project includes an evaluation which describes the physical condition of building systems, identifies variances from present codes, and notes available capacity for structural, mechanical, electrical and communications systems.

## **Code Requirements for Alterations**

For most major alterations an evaluation of code deficiencies is appropriate. See Chapter 1: General Requirements, Codes and Standards, Building Codes for required evaluation. Generally, code deficiencies should only be corrected within the alteration area. However, upgrades may also be required for equipment supporting the alteration area but located outside of it.

New work generally should meet code. An exception would occur when code compliance in new work would create a hazard to the existing system. Alterations in buildings where all systems are replaced must follow current codes.

## **Placing Electrical and Communications Systems in Renovated Buildings**

Even more than in new construction, the optimal placement of engineering systems in the building structure is a crucial element in the success of the alteration. Vertical and horizontal distribution of utilities must be integrated into the architectural concept from the outset.

Chapter 3: Architectural and Interior Design, Alterations in Existing Buildings and Historic Structures, Placing Mechanical and Electrical Systems in Renovated Buildings describes some of the strategies available for placement of power, lighting and communications systems.

**Vertical Distribution.** If new risers are required, they should preferably be located in or adjacent to existing closets. Where there is lack of space, communications risers and electrical risers can perhaps be combined.

**Horizontal Distribution.** Raised access flooring is highly recommended for large modernization projects. Most of the criteria established for raised flooring earlier in this chapter would apply, except that module sizes may have to be varied to fit existing conditions.

In buildings where raised access flooring is not feasible, horizontal electrical and communications distribution may be located in the ceiling. Fortunately, many older buildings have high floor-to-floor heights, which permit an expansion of the existing ceiling space. Vertical zoning of this space between various engineering systems is critical. The zoning could be established according to the principles described earlier in this chapter or according to existing ceiling zones.

In buildings with decorative or inaccessible ceilings, electrical raceways for power and communications lines can be located along walls, or be incorporated into the design of a molding or a special chase between window sills and floor. Raceways should have some additional space for future changes to the electrical and communications systems.

In buildings with fairly close spacing of columns or masonry walls, it may be possible to locate all receptacles, phone and data outlets in furred wall space. The furring should be treated as an architectural feature in historic buildings. If bay sizes are too large for this solution, systems furniture with built-in electrical service is an alternative. Power poles are also an option as long as they are integrated into the architectural design. Poke-through and flat cable should be avoided.

### **General Design Considerations for Alterations**

**Re-use of Existing Equipment.** Existing equipment can be re-used or modified if it is in good condition. Equipment for which replacement parts are no longer available should generally be replaced during alterations. If existing equipment is to be modified, components should be specified to match existing equipment to ensure compatibility and continuation of any applicable warranties.

**Removal of Materials Not Re-used.** Wiring, fixtures and equipment should be removed not abandoned in place, unless removal is impossible.

**Hazardous Material.** Any hazardous materials must be abated or disposed of in accordance with EPA regulations.

**Phasing. Existing** electrical service must be maintained until new facilities are completed and ready for change-over. In occupied buildings phasing of construction should be planned to minimize power outages. Occupants, particularly users in computer rooms, should be given notice of outages before they occur.

**Cost Considerations.** Design decisions should be based on the needs of current and future users and on cost. A life cycle cost analysis is not always necessary but good judgment is. The reasons for selections should be documented.

### **Building Service**

If new switchgear is provided, consider sizing it according to the loads provided in the section Electrical Load Analysis, Table 6-1, of this chapter even if less than the entire building is being remodeled at the time.

### **Secondary Power Distribution**

New panels should be added as required with ample spare capacity. See section Electrical Load Analysis, Standards for Sizing Equipment and Systems in this chapter.

In both large and small remodeling projects, panelboards serving electronic loads should be served from an isolation transformer and sized with consideration given to harmonic currents.

### **Computer Center Power**

Non-linear computer loads should be isolated from normal power. Ensure that the size of the supply transformer for non-linear loads is rated and protected on the basis of input and output current. Provide circuit breakers with true RMS overload protection on the supply and load sides of the transformer and increase size of neutral to twice the size of the phase conductor.

## **Lighting**

**General Renovations.** For small remodeling projects, existing lighting systems should be matched for uniformity and ease of maintenance. In total building modernizations, the guidelines established in the section Lighting of this chapter should be followed.

In structures with ornamental or inaccessible ceilings, indirect lighting offers many possibilities. Fixtures may be located in wall coves or at the top of low columns or partitions.

**Historic Structures.** In historic buildings, the quality of the fixtures and the quality of the light are integral to the architectural integrity of the building. The character of many old buildings has been compromised by poor lighting designs. Designers are encouraged to seek imaginative solutions.

Many historic buildings have beautiful plaster ceilings that do not permit use of lay-in fixtures. Indirect lighting from coves, combined with task lighting, can be a good alternative. Wall sconces are another alternative, particularly in corridors. In public spaces, chandeliers or other decorative fixtures may need to be restored or duplicated. These fixtures may be fitted with compact fluorescent lamps in lieu of the original incandescent lamps if there is no detriment to the historic ambiance of the building. The use of custom designed fixtures is acceptable in historic buildings.

The light source is another important concern. Typically, the existing source is incandescent. Where feasible, the light fixture should be changed to a fluorescent source, with color rendition as close as possible to that of incandescent light.



## **Communications Distribution**

Communications systems are always designed by IRMS, and they will, therefore, furnish raceway systems criteria for alteration projects.

**Telephone.** Generally, older buildings have telephone closets and wiring. For small alterations, the telephone system should probably just be extended to meet new requirements. For major building modernizations, a new distribution system for phone and data should be installed, as described in the section Raceway System for Communications of this chapter.

**Data.** Data wiring is generally non-existent in older buildings. An above-ceiling cable tray should be included in even the smallest projects to facilitate computer networking.

In total building renovations, vertical and horizontal data and telephone distribution should be provided. If there is no existing underfloor system, consider a cable tray loop in the ceiling of the permanent circulation corridors.



## **APPENDIX 6.A**

### **Energy Efficient Design of New Buildings**

The tables on the following pages replace the tables of the same number in ASHRAE/IES 90.1-1989. This replacement is necessary because ASHRAE/IES 90.1 has not yet been updated to reflect legislation effective in 1993.

**FACILITIES STANDARDS FOR THE PUBLIC BUILDINGS SERVICE**

Replacement for Table 6-5 in ASHRAE/IES 90.1-1989  
**Prescriptive Unit Lighting Power Allowance (ULPA), W/m<sup>2</sup>**  
**Gross Lighting Area of Total Building**

Building Type Or Space activity	Gross Lighted Area of Total Building					
	0 to 185 m <sup>2</sup>	185 to 1000 m <sup>2</sup>	1000 to 2300 m <sup>2</sup>	2300 to 4600 m <sup>2</sup>	4600 23000 m <sup>2</sup>	>23000 m <sup>2</sup>
Food Service						
Fast food/Cafeteria	9.9	9.1	8.8	8.7	8.7	8.6
Leisure Dining/Bar	17.2	16.8	16.4	15.9	15.5	15.0
Offices	15.0	14.4	13.7	13.1	12.5	11.9
Retail general	29.0	27.1	24.9	22.0	20.1	18.5
Mall Concourse multi-store service	7.4	7.3	7.0	6.8	6.6	6.5
Service Establishment	30.2	21.8	2.5	17.7	16.6	15.7
Garages	2.7	2.6	2.5	2.4	2.3	2.2
Schools						
Preschool/elementary	14.3	14.3	13.7	13.1	12.5	11.9
Jr. High/High School	15.1	15.1	14.9	14.5	14.0	13.5
Technical/Vocational	19.0	18.5	17.2	16.0	14.6	13.5
Warehouse/Storage	6.5	5.4	4.5	3.9	3.4	3.2

Replacement for Table 6-6a  
**System Performance Unit Lighting Power Allowance**  
**Common Activity Areas**

Area/Activity	UPD W/m <sup>2</sup>	Note	Area/Activity	UPD W/m <sup>2</sup>	Note
Auditoriums	15.0	d	Office		
Corridor	8.6	a	Enclosed offices of less than 1000 m <sup>2</sup> and all open plan offices without partitions of with partitions lower than 1350 mm below ceiling		
Classroom/Lecture Hall	19.4		Reading, Typing and Filing	14.0	g
Elect/Mech Room	1.8		Drafting	23.6	g
General	7.5	a	Accounting	19.4	g
Control Rooms	16.1	a	Open plan offices, 1000 m <sup>2</sup> or larger, with medium partitions 1050 to 1350 mm below ceiling		
Food Service			Reading, Typing and Filing	16.1	a
Fast Food/Cafeteria	8.6		Drafting	28.0	a
Leisure Dining	15.0	c	Accounting	22.6	a
Bar/Lounge	14.0	c	Open plan offices, 1000 m <sup>2</sup> or larger, with large partitions higher than 1050 mm below ceiling		
Kitchen	15.0		Reading, Typing and Filing	18.3	a
Recreation/Lounge	5.4		Drafting	32.3	a
Stairs			Accounting	25.8	a
Active Traffic	6.5		Common Activity Areas		
Emergency Exit	4.3		Conference/Meeting Room	14.0	d
Toilet & Washroom	5.4		Computer/Office Equipment	22.6	
Garage			Filing, Inactive	10.7	
Auto & Pedestrian	2.7		Mail Room	19.4	
Circulation			Shop (Non-Industrial)		
Parking Area	2.1		Machinery	26.9	
Laboratories	23.7		Electrical/Electronic	26.9	
Library			Panting	17.2	
Audio Visual	11.8		Carpentry	24.7	
Stack Area	16.1		Welding	12.9	
Card File & Cataloging	8.6		Storage & Warehouse		
Reading Area	10.7		Inactive Storage	2.1	
Lobby (General)			Active Storage, Bulky	3.2	
Reception & Waiting	5.9		Active Storage, Fine	9.7	
Elevator Lobbies	4.3		Material Handling	10.7	
Atrium (Multi-Story)			Unlisted Spaces	2.1	
First 3 Floors	4.3				
Each Additional Floor	1.6				
Locker Room & Shower	6.5				

**FACILITIES STANDARDS FOR THE PUBLIC BUILDINGS SERVICE**

---

Replacement for Table 6-6b  
**System Performance Unit Lighting Power Allowance**  
**Common Activity Areas**

Area/Activity	UPD W/m <sup>2</sup>	Note	Area/Activity	UPD W/m <sup>2</sup>	Note
Airport, Bus and Rail Station			Hotel/Conference Center		
Baggage Area	8.1		Banquet Room/Multipurpose	15.0	d
Concourse/Main Thruway	4.8		Bathroom/Powder Room	6.5	
Ticket Counter	14.0		Guest Room	6.5	
Waiting & Lounge Area	6.5		Public Area	8.6	
Bank			Exhibition Hall	14.0	
Customer Area	8.6		Conference/Meeting	16.1	d
Banking Activity Area	23.6		Lobby	14.0	
Barber & Beauty Parlor	17.2		Reception Desk	25.8	
Church, Synagogue, Chapel			Laundry		
Worship/Congregational	4.0		Washing	6.5	
Preaching & Sermon/Choir	19.3		Ironing & Sorting	14.0	
Dormitory			Museum & Gallery		
Bedroom	6.5		General Exhibition	12.9	
Bedroom with Study	14.0		Inspection/Restoration	32.3	
Study Hall	9.7		Storage (Artifacts)		
Fire & Police Department			Inactive	2.7	
Fire Engine Room	7.5		Active	5.4	
Jail Cell	4.3		Post Office		
Hospital/Nursing Home			Lobby	8.6	
Corridor	9.7	a	Sorting & Mailing	22.6	
Dental Suite/Exam/Treat	15.0		Service Station/Auto Repair	8.6	
Emergency	21.5		Theater		
Laboratory	18.3		Performance Arts	11.8	
Lounge/Waiting Room	6.5		Motion Picture	8.1	
Medical Supplies	25.8		Lobby	10.7	
Nursery	17.2		Retail Establishments		
Nurse Station	19.4		(Merchandising & Circulation Area)		
Occu./Physical Therapy	15.0		Applicable to all lighting, including accent		
Patient Room	9.7		and display lighting, installed in		
Pharmacy	16.1		merchandising and circulation areas		
Radiology	19.3		Type A	65.0	e
Surgical & O.B. Suites			Type B	31.0	e
General Area	19.3		Type C	29.0	e
Operating Room	64.5		Type D	27.0	e
Recovery	21.5		Type E	26.0	e
			Type F	28.0	e
			Mall concourse	6.5	
			Retail Support Area	23.0	
			Tailoring		
			Dressing/Fitting Room	12.0	

***CHAPTER 3. ARCHITECTURAL AND INTERIOR DESIGN***

---

Notes:

- a Area Factor of 1.0 shall be used for these spaces.
- b Area factor of 1.0 shall be used for all Indoor athletic spaces.
- c Base UPD includes lighting required for clean-up purpose.
- d A 1.5 adjustment factor is applicable for multi-function spaces.
- e See Section 3 Definition for classification of retail establishments.
- f Minimum of 90% of all work stations shall be enclosed with partitions of the height prescribed.





# **CHAPTER 7**

# **FIRE PROTECTION ENGINEERING**

## **General Approach**

The primary goal in the design of fire protection systems for all buildings is the protection of human life and property and the continuity of business activities.

Many Federal buildings, including courthouses and border stations, provide services to the general public. These people are often unfamiliar with the building layout and may not know how to leave a building in an emergency. For this reason GSA has developed policies that enhance life safety provisions beyond those stipulated in building codes.

Another fire protection objective in Federal buildings is the safeguarding of public property. Special criteria, addressed in this chapter, have been developed for spaces that contain major data processing centers, public records and archives.

It is GSA policy to provide automatic sprinkler protection for all new construction and major renovation projects.

## **Codes and Standards**

Model codes and standards adopted by GSA are discussed in Chapter 1: *General Requirements, Codes and Standards*. Chapter 7 is dedicated to a description and explanation of all GSA fire protection criteria that supplement the national codes.

### **Building Codes**

As stated in Chapter 1: *General Requirements, Codes and Standards, Building Codes*, all Federal facilities must comply with the requirements of national model codes for general construction. The egress requirements of the National Fire Protection Association Standard 101 Life Safety Code must be followed in lieu of the means of egress requirements of the national code used.

### **Local Building Codes and Zoning Ordinances**

The policy for compliance with local zoning regulations is described in Chapter 1: *General Requirements, Codes and Standards, Building Codes, Zoning Ordinances*. Local fire protection officials will be given the opportunity to review and comment on GSA projects for compliance with local regulations and for compatibility with local fire fighting practices. Design professionals are encouraged to meet with local fire authorities during the early stages of design and incorporate local requirements to the extent practical.

## **Fire Protection Design Standards**

The standards listed here are intended as guidelines for design. Their use is mandatory only where referenced as such in the text of this chapter. The list is not meant to restrict architects and engineers from using additional nationally recognized guides or standards as desired.

National Fire Protection Association (NFPA): National Fire Codes and Fire Protection Handbook.

Factory Mutual Engineering and Research Corporation (FM): Loss Prevention Data Sheets.

Underwriters' Laboratories, Inc. (UL) Directories:

Fire Protection Equipment Directory.

Building Materials Directory.

Fire Resistance Directory.

Electrical Construction Materials Directory.

Society of Fire Protection Engineers (SFPE):

Fire Protection Engineering Handbook.

## **Site Considerations**

**Emergency Vehicle Access.** Roads, fire lanes and turn-arounds must be designed for the weight and turning radius of fire trucks. At a minimum, one of the long sides of every building must be accessible to fire department equipment. Local fire departments may require additional access for large, unsprinklered buildings.

**Water Supply.** Every building must be supplied from a dependable public or private water main system. See Chapter 2: *Site Planning and Landscape Design, Site Utilities, Water Distribution, Fire Hydrants* for requirements on fire hydrants. For water flow and pressure requirements for building fire protection systems, see the section on *Mechanical Requirements, Fire Suppression Systems* of this chapter.

**Secondary Water Supply.** In areas where the ICBO Uniform Building Code is used, a secondary on-site water supply for high rise buildings in seismic zones 2, 3 and 4 is required. The secondary supply must have enough capacity to provide protection for 30 minutes.

**Remote Rural Buildings.** Some rural areas do not have established water supply systems for fire fighting. For buildings located in these areas (e.g., some border stations) the water supply may be obtained from a tank, cistern, reservoir or other source that can supply a minimum of 37 854 L. Check to ensure that the local fire department can supply the required pressure to the building from the water source.

**Potable Water.** It is not required that the water supply for fire protection be potable. If non-potable water can be used by the fire department, a backflow preventer must be incorporated in the potable water supply, including the sprinkler system. If there is any connection between the non-potable fire protection water system and the public water supply, the requirements of the water supply authority must be followed.

## Architectural Requirements

### Building Occupancy and Floor Area Requirements

**Building Occupancies.** All building occupancies of Federal buildings must comply with the national code used. In addition, GSA has supplemented these by creating "High Severity Occupancies."

**High Severity Occupancies.** In addition to the occupancy classifications of the national building code used, GSA has identified a special occupancy called "High Severity Occupancy," which is defined as:

- Storage areas in excess of 90 m<sup>2</sup> where racks or shelving exceed 3 600 mm in height or general storage warehouses with storage racks over 3 600 mm in height.
- Libraries with stacks higher than 2 700 mm.
- Record centers and archives with open-file shelves.

High Severity Occupancies are permitted only in fully sprinklered buildings. Unlimited floor area is permitted in single story warehouse buildings of Type 1 or Type 2A construction if the storage does not include archives, records, library stacks, flammable liquids or other items of high value or high hazard. Otherwise, the floor area is restricted to 3 700 m<sup>2</sup> or less. See also the section on *Storage Facilities* at the end of this chapter.

Spaces which present a higher hazard than the general building occupancy must be separated by fire-resistant construction as specified by the national building code used or by GSA.

## **Special Occupancy Requirements**

**Places of Confinement.** U.S. Marshal prisoner detention cells and other places of confinement where persons are held under lock during the daytime hours, but not overnight, must be separated from other parts of the building by fire resistant construction in accordance with the national code used. The fire resistant enclosure should include the area occupied by the officials responsible for the prisoners.

Places of confinement used as overnight quarters must be separated from other parts of the building by 2-hour fire resistant construction and must be sprinkler-protected. Institutional sprinkler heads may be used. For additional information see the Administrative Office of the United States Courts (AOC) document *U.S. Courts Design Guide*.

**Child Care Centers.** For special requirements for Child Care Centers see the GSA document *Child Care Center Design Guide (PBS-PQ140)*.

**Museums and Art Galleries.** All museums (including art galleries) in Government owned buildings must be sprinkler protected and comply with NFPA 911.

**Laboratories.** Laboratory design must comply with NFPA 45, Laboratories Using Chemicals. All chemical laboratories must be sprinklered, regardless of size.

*Laboratories in Other Occupancy Buildings.* Laboratories that are an adjunct use in a mixed occupancy building must be located against an exterior wall of the building and must be separated from other occupancies by 1-hour fire resistant construction, including Class C fire-rated doors. See Chapter 3: *Architectural and Interior Design, Space Planning, Specialty Areas, Laboratories*.

**Fire Control Center.** If the building has a Fire Control Center, it must be separated from the lobby by 1-hour fire resistant construction. Other requirements are stated in the national code used. For location of the Fire Control Center, see Chapter 3: *Architectural and Interior Design, Space Planning, Building Support Spaces, Fire Control Center*.

## **Egress Requirements**

GSA mandates the NFPA Standard 101, Life Safety Code for all egress requirements. Specifically, NFPA 101, Chapters 1 through 5 and the portions of Chapters 8 through 30 which reference Chapters 1 through 5 must be followed. These requirements supersede the egress requirements of the national building code used.

In addition, the following criteria apply:

**Travel Distances.** Common paths of travel and dead end corridors must not exceed the distance specified in NFPA 101. However, the NFPA exceptions for sprinkler protection apply to individual floors, even if the remainder of the building is not sprinklered.

Exit travel distances of up to 60 m are permitted in enclosed parking garages with sprinkler protection within or beneath Federal buildings. Exit travel distances up to 90 m are permitted in open air type parking garages that are unsprinklered and up to 120 m if sprinklered. In both cases the exit travel distances are measured in straight lines parallel to the building coordinates.

**Stairs.** Interlocking (scissor) stairs that occupy a single (communicating) stair shaft are considered as only one exit. At least two exits are required for any multi-story building.

**Exit Discharge.** Where an exit stair discharges through two separate fire areas, both at grade, protected corridors may be omitted. Under these conditions, exit markings must be provided within the stairwells to indicate the exit and show the location of other exits. For example, the sign over an exit door might read "Exit to Main Street," and a clearly visible nearby sign would read "Exit to Market Street - Down One Floor."

**Doors.** Vision panels, constructed in accordance with NFPA 80, should always be provided in stairway and horizontal exit doors to reduce personnel hazards.

**Fire Escapes.** Fire escapes as defined in NFPA 101 are not permitted as exits.

## **Fireproofing**

**General Requirements.** The fire resistance ratings of structural elements and construction assemblies must be determined in accordance with ASTM Standard E 119. (The ASTM Test Method (Pass/Fail) shall not be specified because this test has no bearing on fire resistance and performance of sprayed-on fireproofing during a fire.)

**Sprayed-on Fireproofing.** In addition to code requirements listed in the national building code used, all fireproofing (cementitious or fiber) used on GSA projects must be specified to meet the following minimum requirements:

*Deflection:* No cracking, spalling or delamination. Test method ASTM E 759.

*Impact on Bonding:* No cracking, spalling or delamination. Test method ASTM E 760.

*Corrosion Resistance:* No corrosion. Test method ASTM E 937.

*Air Erosion:* Maximum weight loss of 0.27 g/m<sup>2</sup> in 24 hours. Test method ASTM E 859.

*Surface Burning Characteristics:* Maximum flame spread rating of 10 for concealed fireproofing, 5 for exposed fireproofing, and smoke development rating of 0. Test method ASTM E 84.

**Concealed Sprayed-on Fireproofing.** The following are additional minimum requirements for concealed fireproofing (cementitious or fiber):

*Density:* The greater of 240 kg/m<sup>3</sup> or the density required to attain the required fire resistance rating. Test method ASTM E 605.

*Thickness:* The greater of 10 mm or the thickness required for the fire resistive design. Test method ASTM E 605.

*Bond Strength:* 1 030 kPa. Test method ASTM E 736.

*Compressive Strength:* 36 kPa. Test method ASTM E 761.



**Exposed Fireproofing.** The required physical characteristics of exposed fireproofing for density, bond strength, hardness and compressive strength are determined with consideration given to the environment and exposure to vibration, humidity and physical damage. The additional requirements are the same as those listed under sprayed-on fireproofing.

## **Fireplaces**

Fireplaces may not be installed in new or renovated Federal facilities unless approved by the Commissioner of the Public Building Service for executive suites or for ceremonial spaces. Fireplaces must be installed in accordance with NFPA standards.

## **Interior Finishes**

**Flame Spread.** In fully sprinklered buildings or sprinklered areas within fire-rated enclosures, interior finishes must have a flame spread rating of 200 or less and a smoke development rating of 200 or less.

Materials used in exit corridors, exit stairs or other exit enclosures of fully sprinklered buildings must have a flame spread rating of 75 or less and a smoke development rating of 100 or less.

In unsprinklered buildings or areas, materials used for interior finishes must have a flame spread rating of 25 or less and a smoke development rating of 50 or less. Flame spread and smoke developed ratings must be determined in accordance with Test Method ASTM E 84, except that flame spread and smoke developed ratings for exposed loose insulation must be determined in accordance with Test Method CAN4-S102.2- M83.

**Wood Paneling or Other Decorative Materials.** Wood paneling or other decorative finishes may be used. In unsprinklered buildings, paneled rooms may not exceed 460 m<sup>2</sup> in size. Hardwood veneer and solid hardwood paneling are acceptable. For other decorative materials, the flame spread rating must be 75 or less and the smoke development rating 100 or less.

**Furring Spaces.** When an air space exists behind combustible material, the space must be blocked so that no void extends more than 3 000 mm in any direction.

**Materials Treated with Fire-retardants.** Such materials may be used as finishes, provided they have been subjected to a process that treats the material throughout, and provided they meet the required flame spread and smoke development ratings. Combustible materials treated with a surface treatment, such as fire-retardant paint, should not be used as part of the permanent construction.

**Draperies and Curtains.** At a minimum, all draperies and curtains must be made of non-combustible or flame-resistant fabrics (chemically treated). Flame resistant means that the fabric or films (such as thin plastic sheets, cellophane, etc.) must meet the performance criteria described in NFPA 701.

## Mechanical Requirements

### Special Requirements for Air-Conditioning Systems.

**Cooling Towers.** Cooling towers over 60 cubic meters in size built with combustible fill must be provided with automatic sprinkler systems, as defined by NFPA 214. This requirement applies to single towers. A series of single towers with common piping but separated by at least 1 500 mm would not require sprinklers if they were each less than 60 cubic meters

Combustible casings are acceptable in cooling towers provided the fill and drift eliminators are non-combustible. (Polyvinyl chloride and fire retardant treated fiberglass reinforced plastic are classified as combustible.)

In determining cooling tower requirements, use the definitions of NFPA 220 for combustible and non-combustible materials.

**Main Shut-off of Air Handling System.** In buildings that have a Fire Control Center, it must be possible to shut down the air handling system manually, overriding automatic controls. This shut-off switch must be located in the Fire Control Center.

**Duct Smoke Detectors.** Evaluate the benefit of smoke detectors in the return air ducts of non-sprinklered buildings and consult with the fire protection engineer at the regional GSA office. In fully sprinklered buildings, duct smoke detectors are not required in return air ducts. However, smoke detectors should be placed in the air handling unit downstream from the filters and be designed to shut down the individual air handling unit if smoke is detected in its system. Like all smoke detectors, duct smoke detectors must be connected to the building fire alarm system.

**Special Ventilation Systems.** Special ventilation systems must be designed in accordance with these standards:

Spaces generating combustible or explosive vapors, dust, fumes	NFPA 91
Paint spraying booths	NFPA 33
Cooking equipment that produces smoke or grease	NFPA 96

**Heating Equipment.** The following standards apply to the design and installation of heating equipment:

Oil fired	NFPA 31, 85A, 85D
Gas fired	NFPA 54, 85A, 85B
Coal fired	NFPA 85E, 85F
Liquid petroleum gas fired	NFPA 58
Liquid natural gas fired	NFPA 59A

**Gas Piping.** Gas piping design and installation must meet the requirements of NFPA 54, 58, 59A, 85A and 85B.

## **Smoke Management**

The smoke control requirements stated in the national code used apply. In buildings where smoke management is necessary, the systems must be designed to be simple, effective, fail-safe, and reliable. Strategically placed operable windows are acceptable. In buildings where engineered, mechanical smoke management is necessary, systems must be designed to be simple, effective, fail-safe and reliable. Groups of on-off systems are preferable to automatically dampered ducts. Smoke management systems should be supervised by the building fire alarm system.

For simplicity and enhanced reliability, control dampers should be located only at the air handling units controlling outside and return air. Multi-floor zones, up to a maximum of five floors per zone, are permitted to allow integration of smoke control with the building's HVAC system.

In new high-rise construction, exit stair shafts and elevator shafts should be pressurized. The pressurization should be automatic upon activation of the fire alarm system. It should be supervised by the fire alarm control panel. In existing buildings, stair and elevator shaft pressurization should be provided when practical.

## **Fire Suppression Systems**

**Water Supply for Standpipes and Automatic Sprinkler Systems.** The water supply for standpipes and automatic sprinkler systems must meet the requirements of NFPA 13.

**Fire Pumps.** Fire pumps must meet the requirements of NFPA 20, except that they must be sized for the automatic fire sprinkler system ONLY. It is not necessary to size the fire pump for the water flow in the standpipe because the additional flow required for the hose system will be supplied by the pumping equipment on the fire truck.

For buildings exceeding 75 m in height, alternative systems may be developed in coordination with local fire and building officials. All fire pumps must be listed by a nationally recognized laboratory.

**Standpipes.** All standpipes must be connected to the water supply, be permanently pressurized and be installed in accordance with NFPA 14. Dry standpipes are only permitted in spaces subject to freezing.

Risers and cross-connections must be designed to meet hydraulic requirements for standpipe hose streams plus automatic sprinklers, if applicable. In fully sprinklered buildings, the minimum flow in any riser must be at least 1 900 L/min. Additional interconnections, at the tops of risers, for example, may be considered to improve hydraulic characteristics. This is done to reduce pipe sizes as compared to code prescriptive minimums.

**Fire Department Hose Outlets.** On each fire main riser, 65 mm fire department hose outlets must be provided. These outlets must be located at each story and must not be more than 1 500 mm above the floor level. Each outlet must be located in the stair shaft and have an easily removable 40 mm adapter and cap. Threads and valves must be compatible with the local fire department connections.

**Fire Hose and Fire Hose Cabinets.** Fire hoses should not be provided, unless required by the local fire department. In that case, hose cabinets must be marked "For Fire Department Use Only", and arrangements will be made by GSA to have the fire department test the hoses annually.

**Automatic Sprinkler Systems.** Automatic sprinkler protection must be provided in all new construction of GSA-owned space. It is also highly desirable in all leased space. Exceptions are small outbuildings or buildings where sprinkler protection is not economical with respect to mission continuity cost or with respect to building replacement cost. Sprinkler retrofit projects must be designed to allow each zone or floor to become operational as the installation of the system on each floor is completed.

Sprinklers must be provided throughout open plan office space.

Generally, all sprinkler systems must be of wet pipe design. Dry pipe systems may be used in areas subject to freezing; pre-action systems may be used with special GSA approval. Deluge systems may be used to protect cooling towers and transformer vaults. Where high voltage equipment (greater than 600 V) is involved, automatic fire protection must be designed in accordance with NFPA 15. Antifreeze loops are permitted off wet pipe systems for small areas subject to freezing, such as loading docks.

**General Sprinkler System Requirements.** Automatic sprinkler systems must be a hydraulic design and must comply with NFPA 13 and the following supplemental requirements intended to meet the special needs of GSA:

*Fully Sprinklered Buildings.* In fully sprinklered buildings all building areas must be protected with automatic sprinklers, including stairs (on each level) elevator machine rooms, telephone rooms, telephone frame rooms, boiler rooms, electrical closets, electrical switchgear rooms, transformer areas and mechanical rooms.

*Sprinkler Zones.* A sprinkler zone generally may not extend to more than one floor of a building. Each zone must have a water flow alarm capable of transmitting a signal to the fire alarm control panel.

*Quick Response Sprinklers.* Quick response sprinklers must be used throughout except where their use is prohibited by their listing for the specific space.

*Concealed and Recessed Sprinklers.* The use of concealed and recessed sprinklers is strongly discouraged. Preliminary research indicates an increased sprinkler response time by a factor of four or more.

*Sprinkler Flow and Coverage.* Sprinkler flow and coverage is defined in NFPA 13. High hazard and other specialized occupancies must be protected by hydraulic systems calculated at densities and areas of coverage required by the applicable NFPA standards.

*Temperature Ratings.* All sprinkler heads should have an ordinary temperature rating (570C to 770C) unless the ambient temperature of the protected area exceeds 380C.

*Sprinklers in Spaces Housing Electrical Equipment.* Provide annunciation and shut-off valves in elevator machine rooms, the top and pit of hoistways, electrical switchgear rooms and transformer areas. Water flow signals are to be individually annunciated for rooms containing high voltage electrical systems or elevator machine rooms. Where appropriate, the sprinkler zone at the top of the elevator shaft may be combined with the machine room zone.

Sprinklers in spaces housing electrical equipment, including electrical closets, must be equipped with a sprinkler head guard to provide protection against accidental damage.

Pre-action systems are not permitted in elevator hoistways, elevator machine rooms and elevator control maintenance rooms.

*Inspector's Test Connections.* Inspector's test connections must be provided for all zones, so that the water flow switch for each zone can be tested. Connections must have at least a 15 mm outlet discharging to a location that will accept full flow from the connection. This can be a sink, sanitary drain line or an express drain for multi-story buildings. Test connections should be provided adjacent to the sectional control valves. In single story buildings they should be located at hydraulically remote points. Any connection to a sanitary line should be provided with a check valve conforming to the national mechanical code used or the local plumbing code.

**Pre-action System Requirements.** The use of pre-action sprinkler systems is strongly discouraged. Pre-action systems must be designed with a solenoid supervised by the fire alarm system. Any system failure must cause the deluge valve to open, flooding the sprinkler piping system.

The detection system must cause flooding of the pipes before the ceiling temperature is high enough to fuse the sprinkler heads. An alarm signal must be sent to the building fire alarm when the valve trips.

Nitrogen is the preferred medium to maintain pressure in the pre-action sprinkler system pipe, although compressed air is acceptable. The system pressure must be maintained by a regulator connected to the gas source. The pressure must be monitored. High or low pressure must be indicated by a supervisory signal to the fire alarm control panel.

If the detection system that opens the pre-action valve is independent from the building system, it must send supervisory, trouble and alarm signals to the building fire alarm control panel.

**Chemical Fire Extinguishing Systems.** The system must be designed so a pressure switch shuts off all associated power and sends an alarm signal to the fire alarm control panel upon chemical discharge.



The following acceptance test procedures should be incorporated into project specifications when dry chemical extinguishing systems are used:

*Dry Chemical System Acceptance Tests.* After installation, mechanical and electrical equipment is to be tested to verify proper operation. A full discharge test must be conducted after the mechanical and electrical equipment has been fully tested. Plastic or cotton bags must be attached to each nozzle and the system must be activated.

Cooking appliance nozzles must discharge at least 900 g; duct or plenum nozzles must discharge at least 2 200 g. Pre-engineered systems that fail to discharge these amounts are considered unsatisfactory and must be replaced.

*Wet Chemical System Acceptance Tests.* After installation, mechanical and electrical equipment is to be tested to verify proper operation. The distribution piping must be pneumatically tested at 170 kPa for two hours. The installer must certify in writing that the piping has been pneumatically tested and that the pressure after two hours is a minimum of 160 kPa. A discharge test should be performed at the design pressure and must be conducted after the mechanical and electrical equipment has been fully tested. Replace the extinguishing agent container with one containing pressurized water prior to testing. Pre-engineered systems that fail to perform all the required functions will be considered unacceptable and must be replaced or repaired.

**Halon Extinguishing Systems.** The installation of Halon 1301 or Halon 1211 systems or other systems using halogenated hydrocarbons is prohibited in GSA buildings. This prohibition also applies to all portable extinguishers.

## **Electrical Requirements**

### **Power, Emergency Power and Lighting Requirements**

See Chapter 6: *Electrical Engineering* for all electrical requirements other than fire alarm criteria.

### **Elevator Systems**

**General Requirements.** All elevator systems must be designed, installed and tested in accordance with ANSI/ASME Standard A17.1 and the following supplemental requirements. See Chapter 1: *General Requirements, Codes and Standards, Mandatory Design Standards, Elevator Design Standards* and Chapter 3: *Architectural and Interior Design, Building Planning, Selecting Conveying Systems, Elevator Design, and Guidelines for Building Elements, Elevators*.

**Shunt Trip.** When rooms containing elevator control equipment are protected with automatic sprinklers, activation of the waterflow device must simultaneously shunt-trip all power to the elevator controller and notify the fire alarm system of the condition and of the location of the waterflow.

Heat detectors and interlocks must not be used.

**Recall.** Elevators must be recalled to the designated floor upon control room smoke detection.

### **Fire Alarm System**

**General Requirements.** Fire alarm systems should be installed in all new buildings. All fire alarm systems must be designed, installed and tested in accordance with NFPA standards, including applicable appendices. Alarm receipt and signaling must be capable of operating during a single open or single ground fault condition.

Fire alarm systems must be electrically supervised to indicate a break or ground fault condition in all alarm initiating circuits, all alarm indicating circuits and in the circuit from the fire alarm panel to the central station or fire department. Alarm initiating circuits must receive alarms in a maximum of 15 seconds. Trouble and supervisory signals must be received in a maximum of 200 seconds.

At a minimum, systems must be horizontally zoned by floor and the control panel must indicate the location by floor (or by other more detailed zoning) of any alarm or supervisory or trouble signals received.

Fire alarm systems should be provided with a battery back-up power supply in accordance with NFPA 72. Alternate power sources must be approved by the fire protection engineer of the regional GSA office.

**Integration of Systems.** Fire alarm systems must be self contained, stand-alone systems able to function independently of other building systems, such as the BAS, security system and public address system.

However, a supervised interface must exist between the fire alarm and the controls of elevators, air handling systems and other building systems that are designed to change their operation in a fire.

**Special Fire Alarm System Requirements.** Buildings of 12 or more stories must be provided with an emergency telephone system for use by building fire wardens and fire - fighters. The emergency telephone system must be installed in exit stairways and at all elevator lobbies.

The fire alarm system is required to have both audible (non-coded) and visible appliances meeting NFPA 72G requirements. The concept of indirect, primary appliance photo-metrics (use of reflected light) should be applied to visual alarms to the extent practical.

Fire alarm circuits and emergency communications circuits must be installed entirely in metal conduit or electrical metallic tubing (EMT), with a minimum inside diameter of 21 mm, or a system having equal protection against damage by tradesworkers doing repair over the life of the equipment must be shown.

All fire alarm systems should have at least one remote annunciator. The remote annunciator should be placed at the main entrance of the building. The remote annunciator should indicate, at a minimum, the location and type of alarm. Some buildings may require more than one remote annunciator.

**Manual Fire Alarm Stations.** Each fire alarm system must accommodate input from manual fire alarm stations located in exit corridors or in public corridors that are adjacent to a stairway or exit discharge from the building. Additional alarm stations may be provided at any location where there is special risk.

**Water Flow Switches.** Water flow switches must be provided for each floor or fire area that is protected by wet pipe sprinkler systems. Pressure switches must be used to signal water flow for dry sprinkler systems.

**Heat and Smoke Detectors.** Automatic heat or smoke detectors must not be installed instead of automatic sprinkler systems. When required, heat and smoke detectors must be designed and installed to meet NFPA 72E.

Detectors should not be provided where a deluge sprinkler system is used. Pilot lines with quick response sprinkler heads provide a more reliable alternative and should be used instead.

Smoke detectors must be installed in essential electronics equipment facilities, record centers, air handling units and all elevator lobbies. Other areas requiring detection, such as special purpose or high risk areas, may be identified by the regional GSA fire protection engineer during the Design Development review.

**Supervisory Signals.** Supervisory signals must be transmitted under the following conditions:

- By tamper switches, when control valves are closed either two full turns of a valve wheel or upon 10 percent closure of the valve, whichever is less. This applies to control valves in the supply or distribution lines of automatic sprinkler systems, fire pumps, standpipe systems or interior building fire main systems.

- Operation of emergency generator.
- Condition of fire pump and power supply for the pump.
- Loss of primary power to a fire alarm system, fire pump or extinguishing system.
- Low and high air pressure for a dry-pipe or pre-action sprinkler system.
- Low water level in pressure tanks, elevated tanks or reservoirs.
- Low temperature (freezing) conditions in exterior reservoirs, water tanks or dry pipe valve enclosures.
- Abnormal operation signals for emergency generators and fire pumps, such as failure to start automatically, low oil pressure, high cooling water temperature, shutdown from overspeed and low battery condition or battery charger failure.

All separate control panels for special extinguishing systems that receive a supervisory signal from the equipment they monitor must, in turn, send a single supervisory signal to the main fire alarm control panel.

**Trouble Signals.** Trouble signals must be transmitted under the following conditions:

- Failure of central processing unit or peripheral equipment in a multiplex system.
- Wiring faults on supervised circuits, including open, short and ground fault conditions.
- Loss of DC (battery) back-up or charging.
- Detector faults for detectors capable of generating a trouble signal.

- All separate control panels for special extinguishing systems that receive a trouble signal from the equipment they monitor must, in turn, send a single trouble signal to the main fire alarm control panel.

**System Output.** The output from the fire alarm control panel must be appropriate to the type of input (alarm) received, as described below. In all buildings, primary alarms transmitted to the building occupants and to the fire department and other critical signals for emergency equipment operation must function automatically and not depend on the action of a human being. Exceptions are allowed under certain circumstances in buildings housing court facilities (see AOC *U. S. Courts Design Guide*). Any action that is performed automatically by the fire alarm control panel (such as elevator recall or smoke control) must also be possible by manually overriding the automatic sequence from a fire control center or from the control panel of the fire alarm system. When an engineered smoke control system is provided, the fire control center or the fire alarm control panel must have the capability of manually canceling or altering the automatic system response.

**Operation of Manual Fire Alarm, Heat Detector and Water Flow Alarm.** In addition to the requirements stated in the national building code used, operation of a manual fire alarm pull station, heat detector or a water flow alarm switch must result in the following automatic actions:

- Operation of the building fire (evacuation) alarms. Partial or selective evacuation may be necessary in high-rise buildings.
- Operation of other auxiliary features such as door holder release, unlocking of alarmed (locked) doors, fan shutdown or damper actuation (when directly connected to the main fire alarm control panel).
- Activation of a visual indicator at the fire alarm control panel and/or at the remote annunciator panel of the exact zone or device (if alarm annunciation is so detailed) in alarm.
- Waterflow for the elevator control room must also activate the elevator control power shunt trip and shut off all power to the elevator controller.

**Operation of Smoke Detectors.** The activation of a smoke detector connected directly to the main fire alarm panel must cause operation of an audiovisual alarm at the individual detector, if so equipped, and at the main fire alarm control panel and/or remote annunciator panel. Building evacuation should not be initiated by smoke detector activation.

**Operation of the Supervisory System.** Receipt of a supervisory signal, either from an individual device or from a special extinguishing system control panel, must result in the activation of an audiovisual device at the main fire alarm control panel and/or the remote annunciator. The nature (location) of the signal must be indicated to the maximum extent permitted by the degree of zoning or sophistication of the control panel.

**Operation of the Trouble System.** Receipt of a trouble signal, either from an individual device or from a special extinguishing system control panel, must result in the activation of an audiovisual device at the main fire alarm control panel and/or at the remote annunciator. The location of the signal must be indicated to the maximum extent permitted by the degree of zoning or sophistication of the control panel.

**Fire Department Notification.** The fire department must be notified of the fire alarm activation. Signal transmission must not take longer than 90 seconds after initiation of an alarm. Transmission should indicate, at a minimum, alarm signals (detector-activated fire signal, a manual station, a water flow signal) or a supervisory/trouble signal without regard to location in the building. The signal must be reported through:

- A transmitter listed by a nationally recognized testing organization. The transmitter should be connected to a similarly recognized, listed, privately operated central station that has a protective signaling system which conforms to NFPA 71. Automatic telephone dialers are not permitted; however, digital alarm communicator transmitters are allowed when telephone service provides timed-release disconnect. A supervisory condition must transmit to a central station a signal that is different from an alarm signal. A single supervisory signal is sufficient for an entire building.

- An auxiliary tripping device connected to a municipal fire alarm box, to notify the local fire department as described in NFPA 72, Chapter 7.
- A direct, supervised circuit between the building and the local fire alarm headquarters or a constantly manned fire station as stated in NFPA 72, Chapter 8.
- As a last resort, an alternative method approved by GSA.

**Operation of Evacuation Alarms.** Generally, the fire alarm should sound throughout the building to alert all occupants to evacuate. In high-rise buildings over 12 stories, the time needed for complete evacuation may be excessive. In that case, partial evacuation of the immediately affected areas should be announced by alarms which sound on the fire floor and on selected other floors, such as the floor(s) above and the floor below the fire floor. Such selective evacuation is permitted only in fully sprinklered buildings. Coded alarm systems are not acceptable.

**Operation of Voice Communication Systems.** If selective evacuation is used, only the occupants on the fire floor, the floor(s) above and on the floor below must receive the message to relocate or evacuate automatically. Where pre-recorded voice messages are used, message content must be designed to fit the needs of the building (e.g., bilingual) as stated in the programming document.

**Power Supply Source.** Conductors of the power supply circuit must be connected on the line side of the main commercial service to the building. The connection must be on a dedicated circuit. A circuit disconnect device with overcurrent protection must be installed in a location that is accessible only to authorized personnel. The circuit disconnect must be next to the point of connection to the commercial service and must be clearly marked "Fire Alarm Circuit Control."

Any special extinguishing system control panels must have battery backup. In buildings with emergency generators, the fire alarm and any special extinguishing system control panels must be connected to emergency power in addition to the required battery backup.



**Survivability.** Fire alarm systems must be designed to operate during any single fire emergency. The capability to simply report supervised conditions and circuit troubles in a fire is not considered sufficient. Wiring for the fire alarm and for the emergency telephone system must be shielded cable installed in metal conduit or EMT.

At least two vertical cable risers must be installed as remote as possible from each other. The second riser must be separated from the first riser by at least a 1 hour rated fire wall, not common to both risers. One wire should be used as the feed and the other as the return. The wiring must be installed so that loss of one riser does not prevent receiving or sending an alarm signal or recorded message to or from any floor.

Speakers, if used, must be installed so that a break or ground fault does not prevent operation of more than approximately one half of the speakers within a communication zone. They must be alternately connected to two separate circuits feeding each zone, and must be run in separate risers. The speakers must be connected to a return loop running to each zone in one riser and returning in a separate riser.

**Testing.** All fire alarm systems must be maintained and tested in accordance with NFPA 72H.

## **Essential Electronic Facilities**

Essential electronic facilities consist of spaces that have mainframe computers, large scale electronic equipment or data processing equipment. Electronic equipment that is used in typical office space, such as word processing units, terminals or microprocessors, is excluded from the definition.

NFPA 75 must be followed in the design of essential electronic facilities.

**Construction and Segregation Requirements.** Operations using essential electronic equipment must be located in a building of non-combustible construction. Except for small supervisory offices directly related to the electronic equipment operations, no other activity must be located within the fire-rated enclosure.

Originals of important and vital records that are not duplicated elsewhere must be stored in a room with 2 hour fire-rated enclosure.

**Construction and Finish Materials.** Materials used in construction must have a flame spread rating of 25 or less and a smoke development rating of 50 or less. Raised floors must be of non-combustible construction as defined in NFPA 220.

**Smoke Detectors.** In electronic equipment and data storage areas, smoke detectors must be provided on the ceiling, above the ceiling, and in raised floors in accordance with NFPA 72E and 75.

**Sprinkler Protection.** Wet pipe sprinkler protection must be provided throughout all electronic equipment areas, including data storage areas. Sprinkler density must comply with NFPA 13. Sprinkler systems must have separate valves located outside of the protected area, and the valves must be provided with tamper switches connected directly to the building fire alarm system. Connections to the protected area's alarm system is considered supplemental and does not satisfy the building connection requirement.

**Smoke and Fire Dampers.** Fire and smoke dampers must be provided for the ductwork as described in NFPA 75. Ducts serving other areas may not pass through the electronic equipment area.

**Emergency Shut-off Switches.** Emergency shut-off switches must be provided at exits from the electronic equipment area to disconnect power to the electronic equipment and to the air conditioning system. The sprinkler water flow switches should be connected to the same shunt trip breaker. The water flow switch must be equipped with a supervised bypass switch so that maintenance testing can be conducted without disconnecting power to the computer.

## **Storage Facilities**

Storage facilities consist of warehouses, general storage buildings, flammable liquids storage, archives and record centers. Storage areas within buildings with other occupancies and areas incidental to those occupancies are excluded from this definition.

**Special Design Standards.** The following design standards must be used in the design of specific storage facilities:

Flammable and Combustible Liquids	NFPA 30
General Storage	NFPA 231 Series
Record Protection	NFPA 232 Series

## Floor Area Limitations

Table 7-1 shows allowable floor areas for storage occupancies.

Table 7-1  
**Allowable Floor Areas for Storage Occupancies**

Storage Type	Floor Area Permitted	Limitations
General Storage <sup>1</sup>	7 400 m <sup>2</sup>	None
General Storage <sup>1</sup>	Unlimited	Single story building, fully sprinklered, Type 1 through type 4 construction. No archives, records or flammable liquids or other hazardous material storage.
High Severity Storage <sup>2</sup>	3 700 m <sup>2</sup>	None
High Severity Storage <sup>2</sup>	Unlimited	Single story building, fully sprinklered, Type 1 through type 4-2A construction. No archives, records or flammable liquids or other hazardous material storage.

---

<sup>1</sup> Storage rack height limited to 3 600 mm.

<sup>2</sup> Storage rack height 3 600 mm high or higher.

## **Storage Arrangements**

**General Storage Facilities.** The storage arrangements, pile size, pile height and subdivision space between storage and building structure must meet NFPA 231 Series standards.

**Track Files.** Track files or mobile shelving may be used. A track file uses a single aisle to give access to an otherwise solid group of open-shelf files. Access is gained by moving shelf units on rollers along a track until the proper unit is exposed. Track files can fill a very large area with a high fuel load, most of which is out of the reach of sprinkler protection. Track files must meet the following standards:

- A shelving file system must be constructed entirely of steel. At least 1.2 mm sheet metal must be used for all parts of the shelving unit.
- The system must be no more than 2 400 mm high, and a minimum clearance of 600 mm must be maintained between the top of the shelving and the ceiling.
- The back cover of stationary end files must be solid sheet metal.

Each internal unit of a track file may be vertically subdivided by a fire barrier of sheet metal so that a fire on one face of the unit cannot communicate with the opposite face. This means that each shelf of a unit has five metal sides with only the face open, and when two faces are pushed together, the resulting double-shelf unit is fully enclosed. This fire barrier should be considered for each installation. The value of files stored in the unit and the acceptable loss are factors in determining whether fire barriers should be installed in the unit.

## Fire Suppression Systems

**Water Demand.** The calculation for total water demand must include the sprinkler demand, hose streams from interior hose connections and exterior hydrants. A demand of 1 893 L/min should be assumed for interior hose streams for a duration of 2 hours.

**Fire Pumps.** Fire pumps, where provided, must start automatically.

**Automatic Sprinkler Systems.** Automatic sprinkler systems must be provided for all storage facilities. They should be designed in accordance with NFPA 231.

For archives and record centers, sprinkler systems must be designed to deliver 12 L/min+m<sup>2</sup> for the most remote 140 m<sup>2</sup> of floor area, with a minimum pressure of 50 kPa at the most remote sprinkler head. Sprinkler heads in the storage areas and vaults must be rated at 1410C. A rating of 740C must be provided in all other areas.

Large-drop sprinkler heads rated at 1410 C are recommended in record centers and may also be installed in facilities with other types of storage. Installations should have a spacing of not more than 9 m<sup>2</sup> per sprinkler. Alternate sprinkler designs may be used if approved by the fire protection engineer of the local GSA region.

For areas without catwalks, the operating pressure must be at least 170 kPa with the most remote 15 sprinklers operating. With catwalks, the operating pressure for the same remote 15 operating sprinklers must be at least 350 kPa. The pipe diameter must be at least 32 mm.

In record centers where catwalks are used in service aisles for access to rows of open metal shelving, the aisle under the catwalk must be protected with sprinklers designed with a water flow of 1.2 L/min over 460 m<sup>2</sup>.

Sprinklers are not required under the catwalk if the edges of the paper records in the storage boxes above the catwalk are arranged perpendicular to the aisle. The catwalks should be constructed of 2.3 mm (minimum) expanded metal with an open to solid ratio of 40 percent or less.

For all other sprinkler design criteria, see the section *Mechanical Requirements, Fire Suppression Systems* of this chapter.

## **Fire Detection Systems**

**Detectors.** Smoke and heat detectors must be installed in accordance with the NFPA 72 series.

In record storage areas, heat or smoke detectors are not usually required to supplement the sprinkler system. Smoke detectors may be used in special areas within record centers that resemble archives, such as historic materials and record research areas in presidential libraries. Smoke detectors are required in National Archive and Record Storage areas.



## Alterations in Existing Buildings and Historic Structures

The goal of alteration projects is to meet the facilities standards described in this document for new projects.

Renovation projects can occur at three basic scales: refurbishment of an area within a building, such as a floor or a suite; major renovation of an entire structure; and upgrade/-restoration of historic structures.

For small scale renovations, current code requirements and the criteria of this chapter should be satisfied to the extent practical, within the constraints of the existing systems. When extensions of existing systems, such as fire alarm and sprinkler system, are required, the use of compatible components should be considered.

In renovations of entire buildings, the criteria of this chapter should be followed as closely as possible.

Where a historic structure is to be altered, special documents will be provided by GSA to help guide the design of the alterations. The most important of these is the Historic Building Preservation Plan (HBPP) which identifies zones of architectural importance, specific character-defining elements that should be preserved, and standards to be employed. See Chapter 1: *General Requirements, Applicability of the Facilities Standards, Types of Facilities, Historic Buildings*. For fire protection and suppression systems, refer to the GSA publication entitled Fire Safety Retrofitting in Historic Buildings, August 1989.

The fire protection and suppression systems in historic buildings are often deficient by today's standards, and in some cases do not exist at all. Frequently, new systems need to be installed as part of the rehabilitation project. The end result should be a building whose fire protection and suppression systems support its modern use while retaining its historic and architectural character.

Renovation design requires ingenuity and imagination. It is inherently unsuited to rigid sets of rules. Each case is unique; often an equivalent level of protection can be provided by more than one method.

## **Evaluation of Existing Systems**

Every alteration project includes an evaluation which describes the physical condition of building systems, identifies variances from present codes, and notes available capacity for structural, mechanical, electrical and communications systems.

## **Code Requirements for Alterations**

For most alteration projects, an evaluation of existing conditions compared to the current edition of the national code used is appropriate. See Chapter 1: *General Requirements, Codes and Standards, Building Codes* for the required evaluation. Generally, code deficiencies should only be corrected within the renovated area of an existing building, to the extent practical. However, equipment supporting the renovation area, but located elsewhere, may also need to be modified.

## **General Design Considerations for Alterations**

**Sprinkler Systems.** It is GSA policy to add sprinkler systems to all unsprinklered buildings undergoing renovation. Special cases where cost or other considerations make the installation of sprinklers very difficult should be presented to the local GSA regional office for consideration. A brief analysis should explain the possible consequences of interruption of agency function and any risks associated with the proposed occupancy.

For minor alterations, such as a suite or a partial floor, sprinkler installation is not required but is encouraged if the new space will consist of open office space or record storage.

In addition, fire sprinklers should be installed in any renovation where the future occupancy exceeds the fire resistance capabilities of load-bearing elements.

**Sprinkler Coverage.** Sprinkler design for light hazard occupancies should be based on planned (or existing) partition arrangements. In buildings where open office space is subdivided by demountable partitions and "Light Hazard" protection is required by NFPA, sprinkler heads may be installed using "Ordinary Hazard" coverage of one head per 12 m<sup>2</sup> and using the "Light Hazard" flow rate of 4.1 L/min+m<sup>2</sup>. This method of spacing allows for future reconfiguration of partitions. Sprinkler coverage need not be changed during subsequent partition relocations, unless the number of heads in the open office area falls short of the requirements of NFPA Standard 13 by more than 10 percent.

**Sprinkler Layout.** In buildings where historic restoration is part of the design, sprinkler head, sprinkler piping and standpipe layout must be considered with the utmost care. GSA's publication *Fire Safety Retrofitting in Historic Buildings* shows specific examples of fire safety retrofits that safeguard historic features. It also discusses and discourages specific design methods incompatible with historic building design. All exposed elements of the system should be shown and detailed on the architectural drawings rather than the customary method of having the building contractor locate these elements.

Side wall sprinkler heads often are a good solution in spaces with inaccessible ceilings.

**Fire Alarm.** For renovations of entire buildings, the criteria of this chapter apply. For smaller scale renovations, the criteria of NFPA 72 must be satisfied as a minimum.

Sound levels of fire alarm bells and horns must be re-evaluated after wall configurations are altered. When calculating sound levels, a straight-line path should be assumed. Any acoustic absorption material applied to walls in the sound path must be included in the calculation.



# **CHAPTER 8**

# **SECURITY DESIGN**

## **General Approach**

The purpose of the security design in GSA buildings is to protect staff and visitors and to safeguard facilities against criminal activity. In addition, the security design should support the continuity of government operations during civil disturbances, natural disasters and other emergency situations.

GSA is primarily responsible for the perimeter security of Federal buildings while tenant agencies are responsible for the security of their spaces. This chapter describes the design requirements for basic design that will satisfy GSA requirements and has the capacity to cover immediate or future tenant needs.

The most important considerations in the design of a basic building security system are reliability and flexibility. The system must have the capability for alterations as needs change. It should also be designed to accommodate security devices and additional monitoring points that tenant requirements may dictate in the future.

***FACILITIES STANDARDS FOR THE PUBLIC BUILDINGS SERVICE***

---

Security staffing levels vary widely in GSA buildings. Some properties have full 24-hour guard services, others are staffed during office hours only and many may not have any local security staff. Local response capability must be taken into account in the security design concept.

## **Codes and Standards**

Model codes and standards adopted by GSA are discussed in Chapter 1. All electrical and communications systems must meet the requirements of the National Electric Code and NFPA Standard 101.

## **Basic Security Requirements for GSA Buildings**

### **Building Classifications**

Specific design criteria for new buildings and renovations are defined by GSA in a formal risk assessment process. The resulting requirements are stated in the Prospectus Development Study (PDS). Small projects may not have a PDS. In that case the regional GSA office will provide security requirements and guidelines.

Three security classifications are used for GSA buildings. The standards discussed in this chapter apply primarily to Category III buildings, typical general purpose office buildings.

Category I: Buildings which house operations and functions critical to the national interests of the United States. Disruptions of or interference with the governmental activities contained herein would significantly damage intelligence operations, foreign affairs, defense activities, critical materials, etc. Such buildings may present significant targets for espionage, sabotage, politically motivated violence (primarily from foreign interests), communal violence, etc.

Category II: Buildings which house operations and functions essential to inherent governmental functions and the ongoing operations and credibility of the Federal Government. Such buildings house judicial activities, law enforcement agencies, Government records, national assets, personal information, etc. Such buildings may present targets for invasion of privacy, civil disturbance, vandalism, theft, acts of communal violence, etc.



Category III: Buildings which house the normal operations and functions performed by a large number of Federal agencies. In most cases, the activities are similar in nature to those performed in commercially owned buildings. Such buildings may present targets for invasion of privacy, vandalism, theft and other criminal activities.

**Courts.** For security criteria for courts, see the GSA document *Standard Level Features and Finishes for U.S. Court Facilities* and the Administrative Office of the United States Courts (AOC) document *U.S. Courts Design Guide*.

**Child Care Centers.** For security criteria for child care centers, see the GSA document *Child Care Center Design Guide (PBS-PQ140)*.

### **Development of Security Design**

Using the general requirements of the PDS as a starting point, the A/E should develop a security design appropriate to the building use and setting. The criteria of this chapter will serve as a guide in this effort.

The building security design will be reviewed by the regional office of the Federal Protective Service (FPS) at the Concept Design and Design Development stages. During those reviews, specific aspects of the design may need adjustment to suit the operational requirements of FPS.

## **Basic Security System Choices**

The basic security systems to be considered for typical GSA buildings are access controls, intrusion detection, closed circuit television (CCTV) assessment and panic alarm systems. The decision on which systems are required will be made during the development of the PDS, based primarily on the following two factors:

- *Risk Assessment.* The building location and the potential threat of criminal occurrences will be analyzed. In general it is GSA's intent to maintain a standard of security which will deter criminal activity in the building.
- *Available Human Response.* Some GSA buildings are staffed by security guards on a 24-hour basis; others are staffed only during office hours. A large number of buildings have no local security staff at all. Unattended buildings may be monitored remotely from GSA regional centers, which may be located in another city. In many cases, GSA has agreements with local law enforcement authorities to respond to calls for service and alarms generated in the building. The level of expected local surveillance (security guards, police response) will be an important factor in the choice of security systems.

If the project does not have a PDS and the program does not address specific security requirements, the A/E should propose an appropriate security design in outline form in the Final Concept Submission.

**Mechanical Key Locks.** This is the minimum standard for security of all GSA buildings.

**Electronic Access Controls.** Electronic access (card readers, key pads or a combinations of both) controls must be provided if mandated by the PDS. They should also be provided, if appropriate, in light of visitor traffic and number of employees.

**Electronic Article Surveillance.** For buildings housing activities which may attract civil disturbances, the installation of metal detectors should be considered.

**Intrusion Detection System.** If required by the PDS, intrusion detection systems must be provided. The typical devices used on GSA projects are magnetic door switches, break glass sensors and motion detectors. Remote reporting to local police or central station is required if surveillance by local security guards is not possible. Local alarms should not be used unless security guards will be present on site.

**Assessment System.** A CCTV assessment system must be provided if mandated by the PDS. In large buildings that do not require CCTV initially, an empty conduit system should still be considered to facilitate future installation of a CCTV assessment system.

**Panic Alarms.** Duress alarms are appropriate in locations where there is a risk of personal assault. As with CCTV, a prompt local emergency response is essential for them to be effective.

**Location of Security Devices.** Once the decision has been made as to which security systems to include in the project, Table 8-1 should be used as a guide for locating the devices. In many cases it may be good practice to omit a device in the initial building construction, but plan for future installation by providing conduit and junction boxes. Those instances have been designated with the letter "P" in the table.

**Table 8-1  
Summary of Security Devices and Locations**

	Card Access Controls	Intrusion Detection	CCTV Camera	Duress Alarm	Local Alarm	Mechanical Lock
Main entrance	Y	Y	Y			Y
Employee entrance	Y	Y	Y			Y
Other entrances	Y/N	Y	Y/N			Y
Building exits		Y	Y		Y	Y
Loading dock roll-up door		Y	Y			Y
Loading dock personnel door	Y/N	Y	Y		Y	Y
Elevators	Y		P			
Freight elevators	Y/N		Y/N			
Cross corridor doors	Y/P	P	P			
Stairwell doors	P	P	P		P	Y
Building perimeter			P			Y
Loading dock area			P			
Visitor information counter in lobby			P	Y		
Guard station	P		Y	Y		
Security control center	Y	Y		Y		
Electrical closets		P				Y
Mechanical spaces		P				Y
Communications closets		P				Y
Storage rooms						Y
Parking lots	Y/N		P	P		
Parking structure	Y*		Y	Y/P		

Y YES  
P PROVISION  
Y/N YES OR NO, DEPENDING ON CIRCUMSTANCE  
\* FOR VEHICLES ONLY

## Site Security

Generally, GSA buildings do not require site perimeter security. Sites are open to the public, and fences and walls are discouraged. In some urban areas, site perimeter security may be required. Special requirements will be identified in the PDS.

**Parking Lots.** Parking lots may or may not have controlled access. If access controls are required, a gate and card reader should be provided. Parking lots should be served by empty conduit for the future addition of CCTV and/or duress alarm receivers. At a minimum, junction boxes should be provided at the base of every other light pole. For security recommendations regarding planting in parking lots see Chapter 2: *Site Planning and Landscape Design, Plant Materials, Placement*.

**Lighting.** Lighting levels, fixtures and controls for grounds and parking lots are discussed in Chapter 6: *Electrical Engineering, Lighting, Exterior Lighting*.

## **Parking Structures**

The entrance of a parking structure should be equipped with a rolling or biparting grille that can be locked. If the building main entrance has card access control, compatible card readers should be provided for the parking structure. Parking structures that are contiguous with GSA buildings should not be accessible to visitors unless the entrance is staffed and prior arrangements have been made for a visitor parking pass.

Parking structures should have receiver stations for duress alarms or, as a minimum, conduit for future installation of receiver stations.

If CCTV is used, monitors should cover the entrance, the general parking area at each level, and elevator and stair lobbies.

For architectural security design see Chapter 3: *Architectural and Interior Design, Security Design*, and for recommended lighting levels see Chapter 6: *Electrical Engineering, Lighting, Interior Lighting, Illumination Levels*.

## **Parking Garages Below Buildings**

The same design considerations that apply to parking structures apply to parking garages below buildings. In addition, parking garages below buildings have specific criteria for elevator security that are described in Chapter 3: *Architectural and Interior Design, Security Design*.

## Building Security

### Building Entrances

At minimum, all exterior doors must be equipped with key locks. Card access control and intrusion detection devices may be added for enhanced control and monitoring of personnel entering the building.

Building entrances should be limited in number. See Chapter 3: *Architectural and Interior Design, Security Design*.

Table 8-1 gives general guidelines on basic sensors and devices to be considered for building entrances.

**Main Entrance.** The main entrance door may be supervised by personnel during the day or left unlocked. After hours, the main entrance or another designated entrance must be accessible by key or card reader and/or keypad. If card readers or key pads are used, consider adding an intercom outlet. If the building is to have an intrusion detection system, locate balanced magnetic switches on entrance doors. If CCTV is used, cameras are also required on main entrance doors. The CCTV camera should also provide a view of the area immediately outside the door.

**Employee Entrance.** If the building has a separate employee entrance, it may or may not be staffed during office hours. The entrance should be equipped with a card reader and/or keypad. If the building will have a CCTV system, provide a camera to supervise the area immediately outside the door. If CCTV is not part of the original design, consider installation of empty conduit.

**Other Entrances.** Any other exterior doors that serve as occasional entrances for staff or deliveries would be locked during business hours. They require an intercom, doorbell or telephone with pre-programmed office numbers. Card readers or key pads may also be considered.

**Egress Doors.** Doors designed for egress only should not have any operable hardware nor access controls on the exterior. They should be equipped with an instantaneous or, when necessary for enhanced security, a time release touch bar mechanism and local alarm. Provisions for future installation of CCTV to monitor the area inside the door should be considered. Card readers or key pads must not be installed on egress doors.

**Loading Dock Roll-up Doors.** If the building has intrusion detection and assessment systems, roll-up doors should be equipped with a balanced magnetic switch, interlocked with a CCTV camera, to automatically train the TV camera on the area inside the door when the door is open.

**Loading Dock Personnel Doors.** If the building has card access, a card reader should be provided at the personnel door of the loading dock. If intrusion detection and assessment systems are to be included, a balanced magnetic switch interlocked with a CCTV camera should be provided. The interlock should automatically train the TV camera on the inside of the door when the door is open. A local alarm should be set off at the same time.

**Stair Doors Connecting Lobby and Parking Levels.** Stair doors leading to the lobby from parking levels should be provided with card readers and balanced magnetic switches. Egress from stair to lobby must be guaranteed under fire conditions.

**Stair Doors Connecting Lobby to Upper Floors.** This door should be equipped with a mechanical or electric lock to permit locking after hours. Egress from the floor to the stair must be guaranteed under fire conditions. Access controls should not be used.

**Stair Doors at Upper Floor Levels.** In most cases these doors are not locked because stairs are used by staff traveling between floors. However, some tenant agencies may require additional security provisions.

## **Windows**

Glass breakage detectors should be considered on all windows accessible from grade.



## **Other Accessible Exterior Openings**

All exterior openings larger than 62 000 mm<sup>2</sup> which are less than 5 400 mm above the ground or an adjacent roof must have some form of protection against intrusion. This may consist of special louvers or grids of 15 mm reinforcing bars, placed at 150 mm on center and welded at intersections.

## **Building Lobby**

Electrical and communications conduit for the future installation of metal detectors or X-ray scanners should be provided at the (future) line between secure and non-secure lobby. See Chapter 3: *Architectural and Interior Design, Security Design*.

A duress alarm and CCTV camera should be considered for the information desk, guard station and bag check counter (if there is one).

## **Elevators**

All elevator control panels should have provisions for lock-out of every floor, except the main lobby floor. The lock-out should be reversible by key, except that elevators in buildings with card or key pad access systems should be equipped with a card reader or key pad to allow employees access to their area after hours. The card reader or key pad should be part of the cab panel design. See Chapter 3: *Architectural and Interior Design, Building Planning, Security Design and Building Elements, Elevators*.

## **Floor Access**

Corridor doors on upper floors giving access to tenant suites should be provided with card readers or conduit for future card readers.

## **Room Access**

Tenant suites or rooms off public corridors are typically provided with mechanical locks. Doors within tenant suites are provided only with latch sets, as part of GSA's basic building package. When locks are requested by tenants, GSA will provide them at additional cost to the tenant agency.

## **Support Spaces**

Doors to mechanical, electrical and communications rooms and closets, custodial spaces, storage rooms, maintenance shops and other equipment spaces must be key-locked. Conduit for the future installation of balanced magnetic switches should be considered. CCTV cameras should be evaluated for use in trash rooms and trash docks.

## Areas Requiring Special Security Measures

Locks, access controls and intrusion detection devices for special areas may not be part of the basic GSA building package. If not, they will be provided by GSA at the request of the tenant and at additional cost. The following paragraphs serve as general guidelines for the appropriate security provisions for these spaces.

**Spaces Where Cash is Disbursed.** Doors to building spaces where cash is disbursed should be equipped with card access control and balanced magnetic switches. A duress alarm interlocked with a CCTV camera should also be provided. Consider installation of motion detectors in the space. For additional information on security standards for cash handling activities see the GSA Handbook, *GSA Internal Physical Security (PMS P 5930.1)*.

**Child Care Centers.** For security requirements of child care centers see the GSA document *Child Care Center Design Guide (PBS-PQ140)*.

**Computer Centers.** Computer rooms and storage rooms for magnetic media should be designed with access controls, balanced magnetic switches and conduit for future installation of CCTV. For additional information on security standards for GSA computer centers see GSA document PBS 5930.1, Chapter 4.

**Cafeterias.** Cafeterias and other eating areas should be separated from other public areas of the building by lockable doors or rolling grilles.

**Libraries.** Libraries should have key locks.

## **Security System Design**

**General Requirements.** All security subsystems (i.e., access controls, intrusion detection, panic alarm) must be combined to a single integrated electronic security system and should be warranted as a system by the construction contractor. All major system components should be specified to be supplied by a single manufacturer. Manufacturers must be established in the security equipment industry to ensure continued future service and replacement parts.

**Manufacturer's Certification.** Security systems installed in GSA buildings must be listed by Underwriters' Laboratories or Factory Research Mutual Corporation.

**Modular Design.** Devices and equipment should be modular to facilitate addition and replacement of components. Parts and subassemblies should be replaceable as complete units, without modification.

**System Components.** The integrated electronic security system should consist of these components:

- Local processing units.
- Front end processor.
- Two pair processors.
- Operating station.
- Edit station.
- Printer.
- Signal processing display equipment.
- Badging equipment (if card access included).

**System Integration.** Integration of all security subsystems (CCTV, alarms and access controls) is required. The security system may interface, but must not be integrated with the fire alarm system and the building automation system.

**Hardware Locations.** All equipment and devices should be arranged so they are readily accessible to maintenance personnel. Controls should be adjustable with minimum disassembly of equipment.

At least one local processing unit should be located in each communications closet. See Chapter 3: *Architectural and Interior Design, Building Planning, Placement of Core Elements and Distances, Communications Closets* for spacing of communications closets. The panel should be housed in a NEMA-1 cabinet.

**System Zoning.** Each alarm device should be annunciated separately to aid in identification of alarms and troubleshooting of the system.

**Software.** Software should be a commercially available standard software. Custom programs are discouraged because they are more costly and less flexible.

**Provision for Future System Upgrade.** The hardware, software and cabling systems for the security system must be chosen to be expandable to cover future tenant needs. Local processing units must have at least 50 percent spare capacity (real estate) to accept additional card reader, alarm or annunciator modules.

Loading of the network loops for new systems must be limited to 33 percent capacity to permit local processing unit additions without major rewiring.

The integrated electronic security system must be sized to permit expansion to the point where tenant space in the entire building beyond can eventually be connected to the system. If the security system initially includes perimeter and public space security only, expansion potential of 1,000 percent should be provided. This number can be reduced to the degree that tenant security is provided at the same time as the basic building system.

## **Security System Devices**

**Access Controls.** For location of access controls see Table 8-1 and sections *Site Security* and *Building Security*.

*Mechanical Locks.* Mechanical locks must be of the tumbler type, with at least five pins. Deadbolt throw must be at least 25 mm.

*Electric Locks.* Electric locks used on doors in the path of egress must operate in fail-safe mode. Other doors can be set up to operate in fail-secure mode.

*Card Readers and Key Pads.* Access controls may consist of card readers and/or key pads. A combination of card reader and key pad (similar to automated bank tellers) should be considered for building entrances. Plain card readers or coded pads may be sufficient for interior spaces. All card readers within a GSA complex (building and parking) must be of the same type and accept the same card.

The access control system should provide real time monitoring, tracking, restrictions to access and void/valid programming. If security guards will be making rounds in the building, consider patrol tour programming and tracking.

**Intrusion Detection.** For location of access controls see Table 8-1 and sections *Site Security* and *Building Security*.

*Balanced Magnetic Switches.* High security, balanced magnetic switches or biased magnetic switches may be used. They should be housed in metal casing with integral protection for the wire connection.

*Glass Breakage Detectors.* Any type of commercially available glass breakage sensor is acceptable. Sensors should be selected based on type of window glass, window covering and compatibility with heating system.

*Motion Detectors.* Motion detectors are used infrequently in GSA buildings because of the relatively high number of nuisance alarms. Where appropriate, volumetric or infrared detectors may be used.

**Assessment.** For location of access controls see Table 8-1 and sections *Site Security* and *Building Security*.

*CCTV.* CCTV systems should include fixed and pan-tilt-zoom cameras, video switchers or multiplexers, monitors and recorders. If remote reporting is necessary, scan converters, image transmitters and receivers are also required.

Solid state cameras are preferred. Color cameras should be considered for parking garages to improve identification. Either 17 mm or 25 mm formats are acceptable.

Video monitors should have a resolution of 700 to 750 lines. Black and white monitors should be able to produce at least 10 shades of the gray scale. Monitors should have 225 mm screens or larger. Twelve inch monitors should be used for cameras at access control locations.

Video cassette recorders should use 12 mm tape. Time lapse recorders should be considered. Minimum recording time should be specified. Recorders should be able to operate in multiple playback mode (slow motion, fast motion, freeze frame) and should have built-in time, date and camera labeling on each frame. They should also have an automatic alarm event search feature.

Dedicated fiberoptic or coaxial cable should be used to transmit video over the CCTV system.

**Panic Alarms.** For location of access controls see Table 8-1 and sections *Site Security* and *Building Security*.

*Duress Alarms.* Duress alarms mounted in fixed locations may be hard-wired, ultrasonic or radio frequency type, depending on circumstance. Receivers for portable duress alarms should be of radio frequency or ultrasonic type.

## **Signal Communications**

**Wired Systems.** Wired systems are the most common in GSA buildings. Multiplexing is encouraged. Hard wiring is acceptable for small systems or subsystems. Wiring to devices should be point-to-point.

Copper wiring should generally be used between sensors and local processing units. Fiberoptic or coaxial cables are recommended for wiring between components and peripherals of the computer system.

**Radio Frequency Transmission.** With this type of transmission the transmitter and receiver are aligned and set to communicate at the same frequency. Since wiring and conduit is not required, radio frequency transmission has an application in historic buildings. Radio frequency devices must be coordinated with the National Telecommunications Information Agency (NTIA). The procedure for GSA systems is described in the GSA Handbook *Security and Law Enforcement Operations (PBS P 5930.17A)*. GSA-owned equipment does not require coordination with the Federal Communications Commission.

**Line Security and Integrity.** Security wiring must be in conduit. The conduit must be color-coded "GREEN" and used for security wiring only. Lines should be supervised to detect and isolate communications failure. Local processing units should have tamper sensors.

**Remote Reporting.** The security system must be capable of reporting and identifying all alarms at remote locations. Dedicated telephone lines or lines with digital dialing equipment should be used to transmit signals.



## Alarm Monitoring Stations and Control Centers

Alarm monitoring and control in GSA buildings can occur in any of the following configurations:

- Local security control center, which is staffed during the day and may or may not be staffed at night. The processor and operator station will be located in the security control center. A second operator work station should be incorporated into the main guard station if the building has one.
- An unstaffed local alarm monitoring panel and annunciator at a nearby police station or commercially operated central station. The panel and central processors may be located in the building engineer's office, the fire control center or in another secure space. The primary operator work station may be located in the building engineer's office or at the main guard station. Additional operator work stations or local annunciator panels may be located in other locations for the convenience of the responding police force.
- Regional control center, which monitors the security systems of all unmanned GSA buildings within the region.

**Security Control Center.** General space standards for the security control center can be found in Chapter 3: *Architectural and Interior Design, Space Planning, Building Support Spaces, Security Control Center*.

**Operator Station.** The design of the operator station should take into account human factors, such as operator fatigue. Layout should anticipate sequence of operations. Sounds of different pitch and colored indicating lights and color graphic displays assist in prompt identification of alarms.

Monitors and controls should be integrated into a custom designed console which should also contain ancillary equipment, such as telephones, microphone, keyboard and writing surface, within easy reach of the operator.

At a minimum, the following data should be displayed when an alarm is actuated:

- Time, status and zone.
- Operator instructions with telephone numbers of emergency personnel.

### **Back-up Power**

Batteries or uninterruptible power supplies must be used to back up electronic security systems to ensure function during power outages. Back-up power may be designed to be centralized or decentralized and should cover a 2-hour period of operation, unless the building has an emergency generator. In that case, the system should be connected to the emergency power supply and battery operating time can be reduced to 15 minutes. See also Chapter 6: *Electrical Engineering, Emergency Power Systems*.

## Alterations in Existing Buildings and Historic Structures

Generally, systems installed in existing buildings should follow the same guidelines as those designed for new construction.

If a security system already exists, the design engineer should investigate whether it should be maintained, added to or replaced. If the existing system is kept, new devices should be tied into it.

Where a historic structure is to be altered, special documents will be provided by GSA to help guide the design of the alterations. The most important of these is the Historic Building Preservation Plan (HBPP) which identifies zones of architectural importance, specific character-defining elements that should be preserved, and standards to be employed. See Chapter 1: *General Requirements, Applicability of the Facilities Standards, Types of Facilities, Historic Buildings*.

Security system hardware, conduits and junction boxes should be placed in ways that do not damage or visually interfere with character-defining spaces and architectural elements.

These elements include windows, doors, columns, beams, arches, baseboards, wainscots, paneling, cornices, ornamental trim, decorative woodwork and other decorative treatments of floors, walls and ceilings. The end result should be a building whose security systems support its modern use while retaining its historic and architectural character.

***FACILITIES STANDARDS FOR THE PUBLIC BUILDINGS SERVICE***

---